

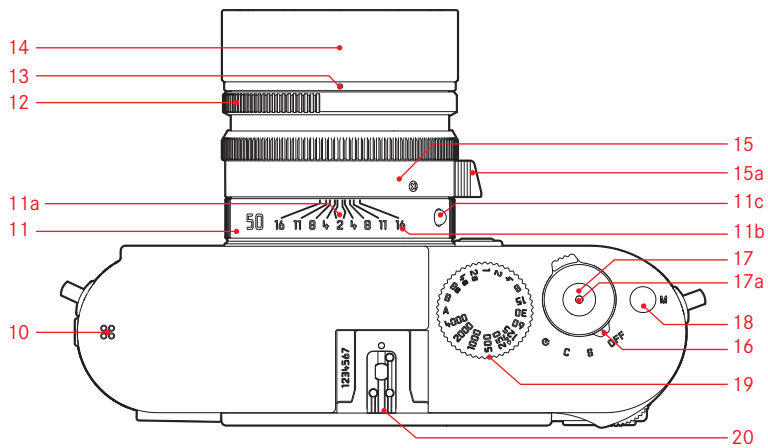

LEICA M Monochrom

使用説明書 | Instructions

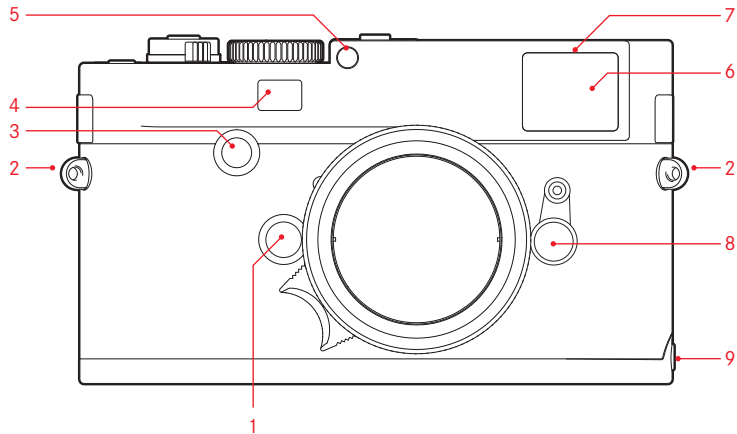

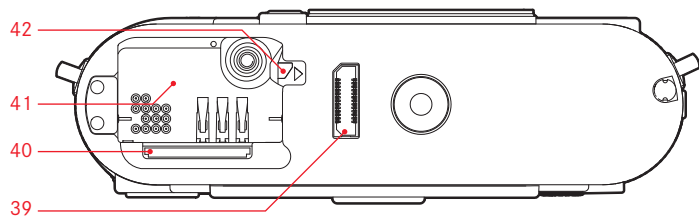
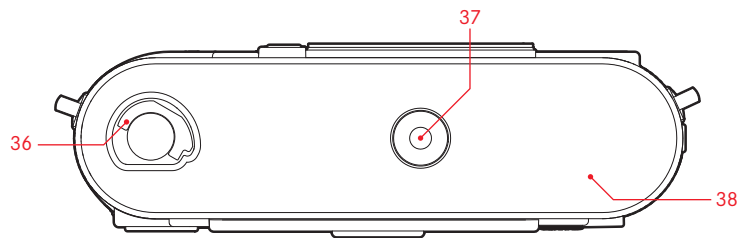
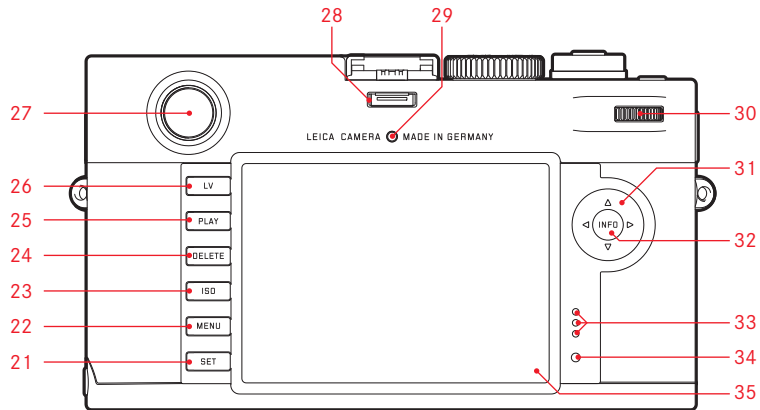





**Leica M Monochrom**  
說明書

## 前言

親愛的顧客：

感謝您購買徠卡 M Monochrom型相機，並恭喜您慧眼獨具選擇了這台獨一無二的數位旁軸相機。衷心期望這台嶄新的徠卡相機，

能帶給您許多樂趣和成果。

我們建議您先閱讀本說明書，以便您能駕輕就熟地使用這台相機的所有功能。

### 提示：

- 徠卡持續對徠卡徠卡 M Monochrom進行改良與最佳化，由於數位相機系統中有許多功能完全以軟體控制，因此某些改良與功能上的擴充，可於出廠後安裝於相機之中。因此，徠卡會不定期提供韌體更新。基本上，我們的相機於出廠時，均已安裝最新的韌體。如果您的相機韌體版本並不是最新，可自行至本公司網站的首頁輕鬆下載最新版本到您的相機上。若在徠卡相機網站上為您所購買的產品進行註冊，您可選擇訂閱新聞通訊，以便取得韌體更新的消息。有關相機的註冊和韌體更新資訊，以及可能的說明書規格變更與補充資訊，開啟以下網頁上的「顧客服務區」：  
<https://owners.leica-camera.com>  
若要得知您的相機是否已安裝了最新的韌體，請查閱手冊 **Firmware** (韌體) 一節的說明 (**SETUP** 區域，請看第 26、116頁)。
- 開始操作相機之前，請先檢查附贈的配件是否齊全。

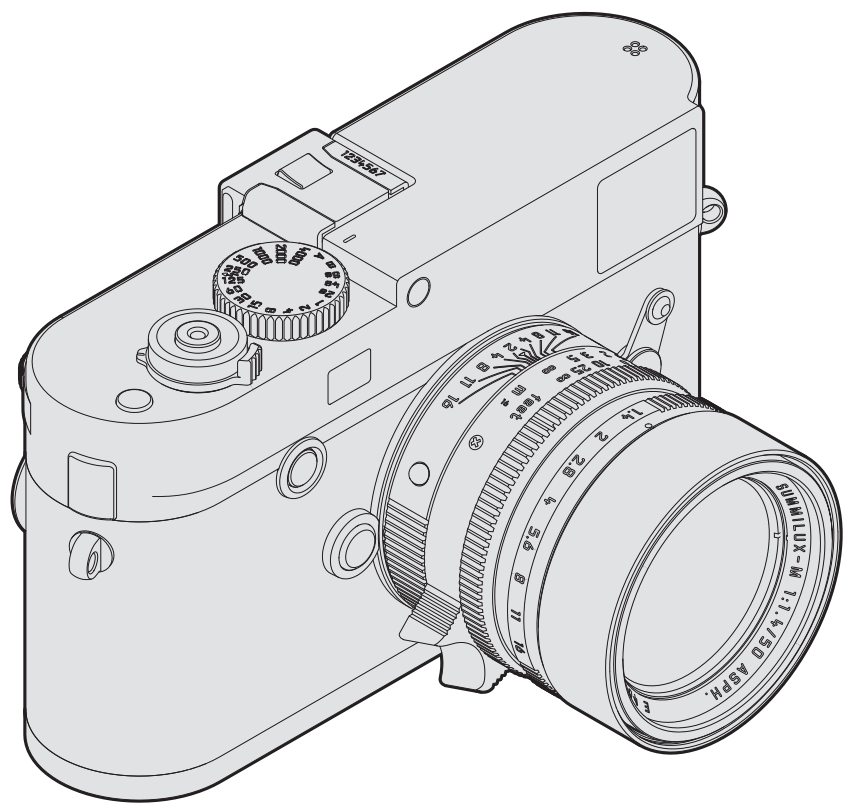

## 目錄

警告提示 .....	6	預設功能	
法律提示 .....	6	相機基本設定	
電機與電子裝置的廢棄處置 .....	7	選單語言 .....	30
		時間和日期 .....	30
各部件名稱 .....	8	自動關機 .....	32
		訊號聲 .....	33
簡易說明 .....	10	攝影基本設定	
詳細說明		鏡頭偵測 .....	34
準備工作		漸暈修正 .....	35
裝上揸帶 .....	12	檔案格式 .....	35
電池充電 .....	13	解析度 .....	36
更換電池與記憶卡 .....	16	ISO感光度 .....	37
徠卡M型鏡頭 .....	19	影像特性 / 對比、銳利度 .....	39
安裝鏡頭 .....	21	色調 .....	39
取下鏡頭 .....	21		
最重要的設定/操控元件		取景框線 - 測距觀景窗 .....	40
相機的開機與關機 .....	22	視野撥桿 .....	42
快門按鈕 .....	23	顯示螢幕 .....	44
連續拍攝 .....	24	實時取景模式 .....	44
快門時間設定轉盤 .....	25	水平儀 .....	45
選單操控功能 .....	26		



測距.....	46	其他功能	
使用光學測距儀.....	46	資料夾管理.....	86
在實時取景模式下使用顯示幕.....	48	將記憶卡格式化.....	88
畫面上攝影主題 清晰度標示.....	49	將資料傳送到電腦.....	89
開啟/關閉測光表.....	50	Adobe® Photoshop® Lightroom®.....	92
測光方法.....	50	Leica Image Shuttle®.....	92
曝光模式.....	52	使用DNG原始資料.....	92
光圈先決.....	52	安裝韌體更新.....	93
測光值儲存.....	53	其他	
曝光修正.....	54	系統配件.....	94
自動包圍曝光.....	56	備用件.....	97
手動設定曝光.....	58	安全及保養須知	
B設定/ T功能.....	58	一般注意措施.....	98
超出或低於測量範圍.....	59	保養指示.....	100
閃光燈模式.....	60	清潔感測器/灰塵辨識.....	104
其他功能		存放.....	106
拍攝影片.....	66	故障及其排除方式.....	106
錄音.....	67	附件	
以自拍器攝影.....	68	顯示訊息.....	108
標示影像檔案與著作權保護.....	68	選單項目.....	116
用GPS功能記錄攝影地點.....	69	關鍵字索引目錄.....	118
使用者/使用者特定風格.....	71	技術資料.....	119
回復所有個別設定.....	73	徠卡M型鏡頭.....	124
播放模式.....	74		

本產品之CE標誌代表本產品遵守適用之歐盟規章的基本要求。

## 警告提示

- 現代電子元件對於靜電放電的反應很敏感。例如在合成地毯上走動就有可能產生好幾萬伏特的靜電，若在這時候碰觸您的相機，而它又剛好坐落在導電的地面上，就可能引發放電現象。只發生在相機機身表面的放電現象不會對相機內部的電子零件造成損害。通到外部的接腳，例如電池或背板上的接點，雖有內建的保護電路，為了安全起見仍應盡量避免碰觸。
- 請您在偶爾清潔接點時不要使用光學用微纖維布（合成布），而應使用棉布或亞麻布！如果您刻意抓住暖氣管或水管（可導電的「接地」材料），則可確保釋放您身上可能帶著的靜電電荷。儲藏相機時，請勿拔下鏡頭或鏡頭接座蓋，且應將其放在乾燥的地方，以避免這些接點沾染污垢或氧化。
- 僅能使用本廠推薦的配件，以避免產生干擾、短路或觸電等問題。
- 請勿嘗試拆除機身零件（外蓋）；專業修理工作僅能由經授權的維修單位執行。

## 法律提示

- 請遵守著作權法。未經授權自行轉載或公開播放轉錄媒體，例如經由錄影帶、CD、他人發行或寄送的內容，皆有可能違反著作權法。
- 此點亦適用於所有附贈的軟體。
- SD、HDMI、CF及USB標誌都是註冊商標
- 其他在本說明書提到的商標、公司及產品名稱皆為相關公司的商標或註冊商標。



## 電機與電子裝置的廢棄處置

(適用於歐盟以及其他有分別回收系統的歐洲國家)

本裝置包含電機及 / 或電子組件，不得棄置於一般家庭垃圾內！請務必將本裝置送至地方政府設置的資源回收點。您不須為此付費。此裝置若含有可更換式電池或充電電池，請務必先將這些電池取出，並按當地規定進行廢棄物處理。

其他和本主題相關的資訊，可從當地政府、廢棄物處理公司或在購買產品的商店處得知。

## 相機的製造日期

您可在保固卡中的貼紙或在包裝上找到相機的製造日期資料。

日期格式：年 / 月 / 日



## 各部件名稱

封面和封底上的圖片

### 前視圖

1. 鏡頭解鎖鈕
2. 攜帶吊耳
3. 對焦按鈕
4. 測距儀視窗
5. 亮度感測器<sup>1</sup>
6. 觀景窗接物鏡
7. 自拍器發光二極體
8. 視野撥桿
9. 底板上的停止點

### 俯視圖

10. 麥克風
11. 固定環, 隨附
  - a. 對焦指標
  - b. 景深刻度
  - c. 用於更換鏡頭的紅色指示鈕
12. 光圈設定環
13. 用於光圈設定的指示點
14. 遮光罩
15. 焦距設定環, 含
  - a. 握把
16. 含如下停格位置的主開關
  - OFF (相機關機)
  - S (單張攝影)
  - C (連續拍攝)
  -  (自拍功能)
17. 快門按鈕, 包含
  - a. 快門線用螺紋
18. 影片快門按鈕
19. 含如下停格位置的快門時間設定轉盤
  - A快門時間自動控制
  - 快門時間 $1/4000$  - 8秒 (包括中間值)
  - B (長時間曝光)
  -  閃燈同步時間 ( $1/180$ 秒)
20. 閃光燈靴座

<sup>1</sup> 有觀景窗座的徠卡M型鏡頭會遮住亮度感測器。關於這類鏡頭以及其它鏡頭的運作方式, 請參閱第 108頁「顯示訊息/觀景窗內」以及第 19頁「徠卡M型鏡頭」兩節的說明。

## 後視圖

21. **SET**按鈕
  - 開啟攝影參數選單
  - 開啟選單內的子選單
  - 套用子選單內選取的設定或功能
22. **MENU**按鈕，用於開啟或關閉主選單及子選單
23. **ISO**按鈕，用於開啟感光度設定
24. **DELETE**按鈕，用於選擇刪除功能
25. **PLAY**按鈕
  - 啟動（連續）播放作業
  - 返回全畫面顯示模式
26. **LV**按鈕，用於開啟及關閉實時取景
27. 觀景窗目鏡
28. 外接式電子觀景窗接頭/麥克風轉接頭<sup>1</sup>（取下護蓋）
29. 螢幕亮度感測器
30. 設定轉盤
  - 操控選單
  - 設定所選擇的選單項目或功能
  - 設定曝光修正值
  - 放大或縮小觀賞中的相片
  - 翻閱記憶體中的相片
31. 十字鍵
  - 操控選單
  - 設定所選擇的選單項目或功能
  - 翻閱記憶體中的相片

32. **INFO**按鈕
  - 在拍攝時顯示設定值或資料
  - 在播放模式下顯示拍攝資料
  - 套用設定值
33. 喇叭
34. 發光二極體，可用於顯示相機正在攝影/記憶卡正在儲存資料
35. 顯示幕

## 仰視圖

### （裝上底蓋）

36. 底蓋的門柄
37. 三腳架螺孔A 1/4, DIN 4503 (1/4" )
38. 底蓋

### （取下底蓋時）

39. 多功能M型手把的接頭<sup>1</sup>
40. 記憶卡插槽
41. 電池插槽
42. 電池門鎖推桿

<sup>1</sup> 隨產品提供的配件，請看第96頁

## 簡易說明

請備妥下列物品：

- 相機
- 電池
- 記憶卡 (請自行購買)
- 充電器與電源線

## 準備工作

1. 電池充電 (請看第13頁)
2. 安裝電池 (請看第16頁)
3. 安裝記憶卡 (請看第18頁)
4. 開啟相機 (請看第22頁)
5. 設定選單語言 (請看第30頁)
6. 設定日期與時間 (請看第30頁)
7. 視需要進行記憶卡格式化 (請看第88頁)

## 攝影

8. 安裝鏡頭 (請看第21頁)
9. 快門時間設定轉盤設定到A (請看第25頁)
10. 設定主題清晰度 (請看第46頁)
11. 開啟相機 (請看第22頁)
12. 開啟測光 (請看第23頁)
13. 視需要調整曝光 (請看第58頁)
14. 快門開啟操作 (請看第23頁)

### 提示：

拍攝影片步驟說明 (請看第66頁)。

## 檢視相片

相機在出廠前已設定為自動短暫播放上次拍攝的相片 (請看第74頁)。您可以隨時使用**PLAY**按鈕不限時播放 (請看第74頁) 按壓十字鍵的左側或右側，觀賞其他相片 (請看第80頁)。往右轉動設定轉盤放大相片 (請看第81頁)。

## 刪除相片

按 **DELETE** 按鈕，然後依照畫面上的指示操作 (請看第82頁)。

# 詳細說明

## 裝上揸帶

### 準備工作

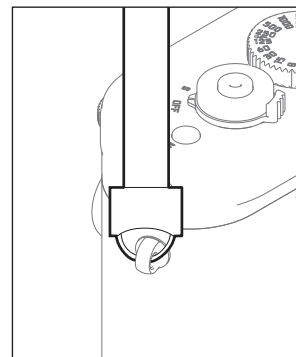
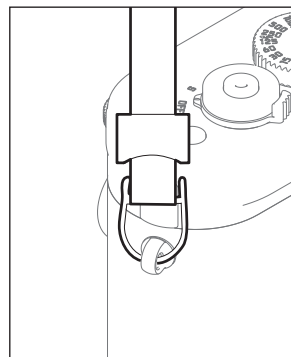
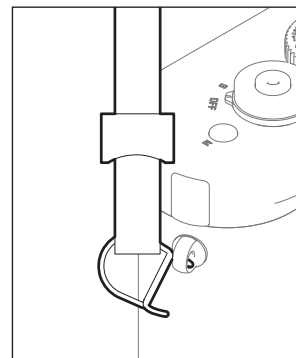
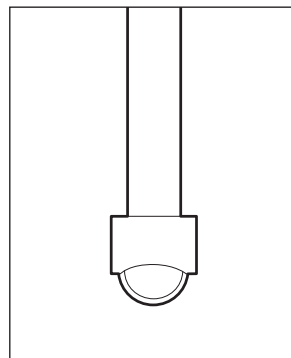



## 電池充電

徠相機的電源來自鋰離子充電電池。

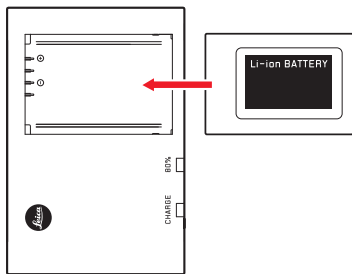

- 有**CHARGE**標示的綠色LED閃爍，表示充電作業開始了。電池電力一旦達到其容量的 $\frac{4}{5}$ ，有**80%**標示的黃色LED會亮起。電池完全充飽電後，綠色的LED就會持續發亮。

## 提示：

代表**80%**的LED會依充電特性在大約2小時後亮起來。

完成充電後，應該拔除充電器電源。無論如何，您不用擔心會有過度充電的問題。

**注意：**

- 請務必使用本說明書裡描述的充電電池種類（訂購編號14 499）或是徠卡相機公司所列舉之充電電池種類。
  - 這些充電電池僅能使用專屬的（亦即以下所說明的）裝置充電。
  - 違反使用規定，以及使用不合規定種類的充電電池，可能會導致電池爆炸！
  - 充電電池不得長時間暴露於熱源或日曬、溼度或濕氣之下，亦不得置於微波爐或高壓容器內，否則會有失火或爆炸的危險！
  - 充電電池內的安全閥應確保釋放，因不當操作或其他原因所產生的過度壓力。
  - 僅能使用本說明書提及說明的充電器（訂購編號14 494）。使用其他非經徠卡相機公司許可的充電器，可能會使充電電池受損，嚴重時甚至可能引發嚴重、危及生命的傷害。
- 隨機附贈的充電器僅能用於充電電池的充電，請勿嘗試使用於其他用途。
  - 充電器已連接電源的情況下，請切勿使用隨機所附的車用充電器。
  - 充電時使用的電源插座，應置於隨手可及之處。
  - 充電器及電池不可以拆解。修理工作只能由取得授權的工廠執行。

**提示：**

- 首次使用相機前，應該先為充電電池充電。
- 充電電池的溫度必須在10° -30° C之間才能夠充電（否則充電器會無法啟動或會自行再度關機。）
- 鋰離子充電電池不管有多少剩餘電力，都可再行充電。若電池電力還未耗盡，則充飽電所需的時間會較短。
- 充電過程中，電池會升溫。這是正常現象，不是故障跡象。
- 充電器的兩個訊號燈若於充電啟動後快速閃爍 (>2Hz)，此乃充電異常的警訊（可能是因為已超越充電時間上限、電壓或溫度異常，或是有短路現象）。這時，請拔除充電器的電源並取出充電電池。請確定前述溫度條件吻合，再重新充電。若無法排除此問題，請與您的經銷商、所在國家的徠卡代理商或徠卡相機公司聯絡。
- 新的充電電池要充分充電、放電（讓相機的運作耗盡其電力）兩三次後，才能充出其最高電力。這種充分放電作業應該每充放電25次，就重新執行一次。為讓充電電池的使用壽命達到最長，應避免長時間放置在溫度極高或極低的環境中（例如在夏天或冬天，放在停駛的汽車裡）。
- 每顆充電電池的使用壽命，即便在最佳的使用條件下都是有限的！經過幾百次充放電後，其工作時間即會明顯縮短。
- 最晚應每四年更換一次電池，因其功效會逐漸減弱，特別是在冬天將不保證電池的運作可靠度。
- 損壞的充電電池，應該遵照相關規定(請看第101頁)處置。
- 相機裡有一顆內建的備用充電電池，用以儲存時間和日期，最長可達2個月。其充電電源是那顆可更換的充電電池。如果備用充電電池的電力耗盡，您必須安裝一顆有電力的可更換式電池為它充電。在裝上可交換式充電電池後，備用充電電池大概幾天後可充到完整容量。在這段充電期間，相機必須保持在關機狀態。

## 更換電池與記憶卡

將主開關設定到OFF。

### 重要：

如果顯示幕右下方代表記憶卡上數據保存的紅色LED閃爍，請勿打開底蓋或取出記憶卡或充電電池。否則，尚未（完全）儲存好的相片資料可能會丟失。

### 取下底蓋

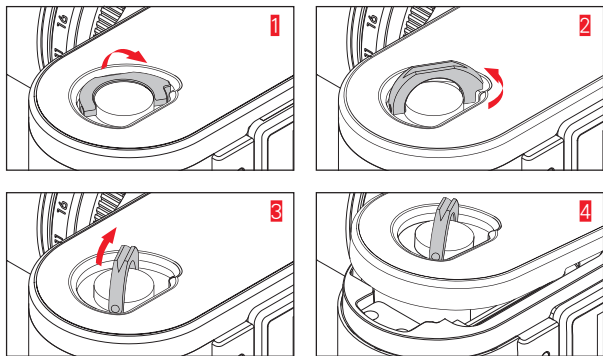

### 安裝電池

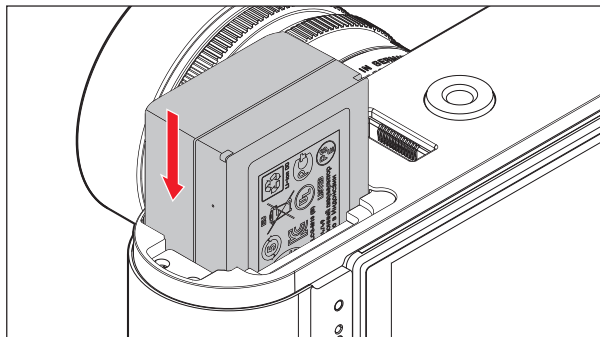

### 取出電池

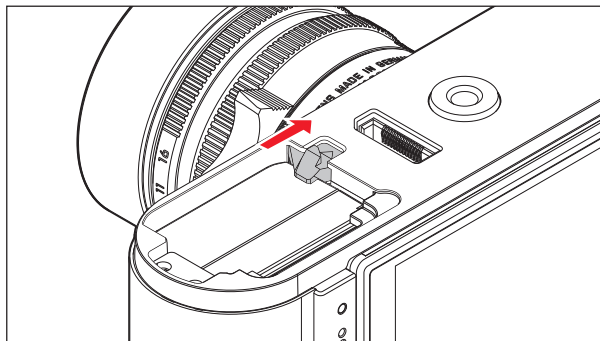

## 充電狀態顯示

在攝影模式下壓按 **INFO**，即可在顯示螢幕上檢視電池的充電狀態。

### 提示：

- 若長時間不使用相機，請取出充電電池。
- 相機內的電池電力耗盡後（請參閱第13頁「為電池充電」的最後一個提示），最遲二個月後，就必須重新進行日期與時間設定。
- 充電電池的電力不足或裝入舊電池時，每使用一次相機功能，就會出現警告訊息或警告指示，功能也會受限或完全無法使用。

## 可用的記憶卡

相機將相片儲存在一個SD（安全數位）、SDHC（高容量）或SDXC（超高容量）記憶卡內。

SD/SDHC/SDXC記憶卡有很多供應商，而且有各種容量和讀寫速度。這些高容量及容許高速讀寫的特性，可以快速記錄及播放資料。

SD/SDHC/SDXC記憶卡具備防寫開關，可防止意外寫入或刪除卡上的資料。此開關位於記憶卡上無斜角那邊的推桿，推到下面標示著LOCK[上鎖]的位置即可保護記憶卡上現存的資料。

### 提示：

請勿碰觸記憶卡上的接點。

## 安裝記憶卡

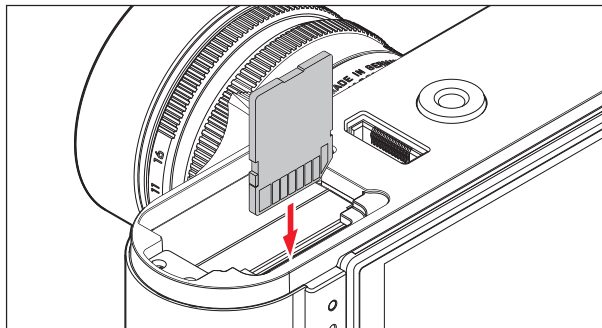

## 取出記憶卡

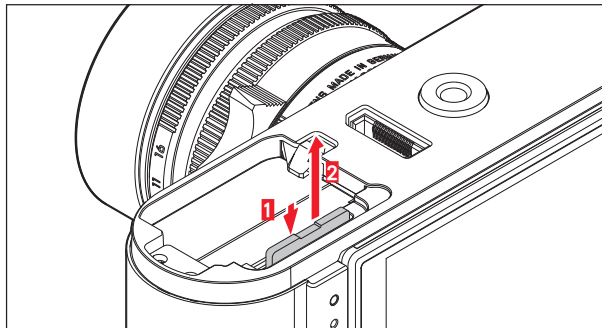

## 提示：

- 市面上供應的SD/SDHC/SDXC卡廠牌種類繁多，徠卡相機公司無法全面檢驗所有品牌與型號的相容性和品質，使用其他型號的記憶卡雖然不至於使相機或記憶卡受損，但鑒於有些記憶卡，尤其是所謂的「白牌」產品，並不符合SD/SDHC/SDXC標準，徠卡相機公司無法擔保其功能。
- 拍攝影片需要很高的寫入速度。
- 若無法插入記憶卡，請檢查方向是否正確。
- 在相機開啟狀態下卸下底蓋或是拿出記憶卡後，監控螢幕上原有的訊息顯示會消失，而會出現相關的警示訊息：
  - Attention Bottom cover removed
  - Attention No card inserted.
- 電磁場、靜電電荷以及相機和記憶卡上的損傷，可能會造成記憶卡上的資料損壞或遺失，所以建議將資料傳送至電腦儲存（請看第89頁）。
- 基於同樣理由，記憶卡應盡量存放在抗靜電的容器內。

## 徠卡M型鏡頭

原則上：可以使用大部分徠卡M型鏡頭，少數例外及限制詳見下列說明。

其適用性與相機鏡頭配備無關——無論接座是否有6位元辨識碼。即使沒有這項額外的配備，亦即使用沒有辨識碼的徠卡M型鏡頭時，相機通常還是能展現優秀的攝影效果。

使用這類鏡頭時，為獲得最佳相片品質，請自行輸入鏡頭型號（請看第34頁）。

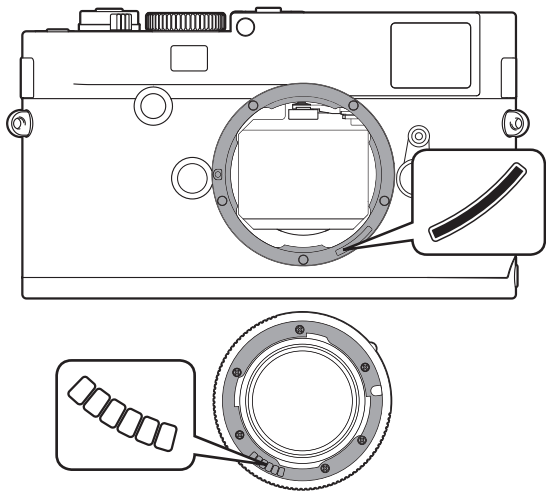

## 重要：

- 無法使用的鏡頭：
  - Hologon 1:8/15mm,
  - 含微距功能的Summicron 1:2/50mm,
  - 縮筒式的Elmar 1:4/90mm（製造年代：1954至1968）
  - Summilux-M 1.4/35mm（非球面，製造日期1961-1995，加拿大製）有某些個別產品無法裝在相機上，以及無法對焦到無限遠處，徠卡客服部門可修改這些鏡頭，讓其亦能使用在相機上。
  
- 可使用，但有相機或鏡頭受損的風險：
  - 縮筒式鏡頭只能在鏡筒伸出時才能使用，亦即是其鏡筒絕對不可縮進相機裡。現在的Macro-Elmar-M 1:4/90mm不受此限，因為其鏡筒在縮筒狀態下並不會伸進相機。

- 可使用，但有限制條件：  
機的測距觀景窗有很高的精度，可是光圈全開時景深會很淺，所以我們無法保證使用135mm鏡頭時能準確對焦。在這種情況下，我們建議您至少縮降2格光圈。在實時取景（請看第44頁）及其他調整模式下，可以不受限地使用135mm鏡頭。
- 可使用，但無法進行Classic測光（請看第50頁）：
  - Super-Angulon-M 1:4/21mm
  - Super-Angulon-M 1:3.4/21mm
  - Elmarit-M 1:2.8/28mm，製造序號低於2 314 921者

**提示：**

- 徠卡客服維修部門可以替許多徠卡M型鏡頭加裝6位元辨識碼。（地址請看第124頁）。
- 相機除了徠卡M型鏡頭（不論有無辨識碼）外，亦可使用徠卡M型轉接頭R配件（請看第94頁）安裝徠卡R鏡頭。



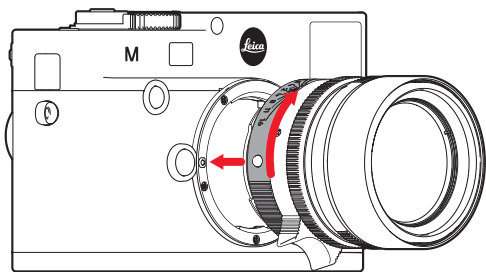

1. 關閉相機
2. 握住鏡頭的固定環
3. 將鏡頭的紅色指標鈕對準相機機身的解鎖鈕
4. 依此方位直直插入鏡頭
5. 稍微向右旋轉，直到聽到並感覺到鏡頭卡住定位

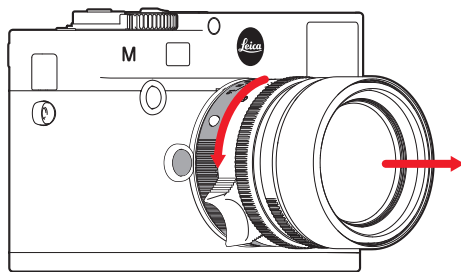

1. 關閉相機
2. 握住鏡頭的固定環
3. 將相機機身上的解鎖鈕往下按
4. 將鏡頭向左轉，直到其紅色指標鈕對準解鎖鈕為止
5. 直接取下鏡頭

### 提示：

- 原則上：為了防止灰塵等異物侵入相機內部 - 相機原則上應一直裝著鏡頭或以機身蓋罩上。
- 基於同樣理由，更換鏡頭的動作應迅速，而且儘可能在無塵的環境中進行。
- 相機或鏡頭後蓋不應放在褲子口袋裡，因為一旦沾上灰塵，裝到相機上時灰塵便會進入相機內部。

## 最重要的設定/操控元件

### 相機的開機與關機

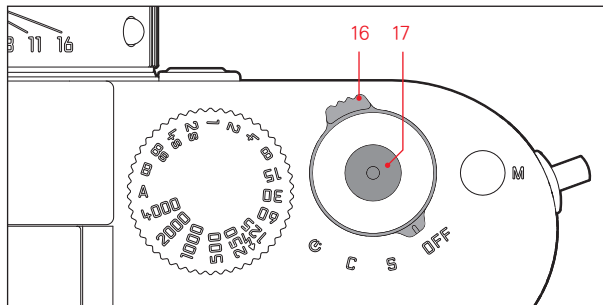

相機使用主開關開機和關機。位於快門鈕下面，是一個有四段位置的定格式撥桿：

- OFF** - 相機關機
- S** - 切換到單張拍攝模式  
按下快門按鈕，每次會拍攝一張相片，與是否按住不放無關。

- C** - 切換到連續拍攝模式  
只要所使用的記憶卡和相機內部暫存記憶體有足夠的容量，按下快門按鈕相機就會連續拍攝。第一次連拍時，會以較快的速度至少連續拍攝16張，之後連拍頻率會變慢。
- ☺** - 自拍  
按下自拍器會開始倒數預設的前置時間（請看第68頁），然後拍攝相片。

### 開機

開機後，亦即設定啟動**S**、**C** 或 **☺** 功能後，顯示幕右下角的LED會短暫發亮，觀景窗內會顯現訊號（請看第108頁）。

### 提示：

開機約1秒之後，即可到達待命狀態

### 關機

若透過選單操控預先設定了自動關機時間（請看第頁的 節電設置），即使主開關未設定在**OFF**的位置，相機還是會**Auto Power Off**，請看第32頁。

**提示：**

相機長時間不使用或是放在相機袋裡時，應該要用主開關關機。如此可阻斷電力消耗，否則測光表自動關機、顯示訊息熄滅後，相機在待命模式下還是會繼續耗電。藉此也可防止不經意按壓到快門鈕而攝入影像的意外發生。

**快門按鈕**

快門鈕有二個壓段：

1. 按到第一個壓點
  - 啟動測光功能及觀景窗內的訊息顯示
  - 儲存光圈先決時的測光值，亦即相機所決定的快門時間（請看第53頁的「儲存測量值」章節）
  - 重新啟動進行中的自拍倒數計時（請看第68頁）

若將快門鈕按在這個壓段不放，顯示訊息就會維持顯示中。若之前是設定在播放模式，則相機就會切回攝影模式。若相機之前是設定在待機模式，則會重新啟動並開啟顯示訊息。放開快門鈕後，測光系統和顯示訊息會維持大約30秒的啟動狀態（請看第50頁以下「測光」章節的詳細說明）。

**提示：**

在下列情況，快門鈕會維持在被封鎖狀態：

- 內部緩衝記憶體（暫時）處於空間不足的狀態，例如連拍 ≥16 張相片之後，或是
  - 插入的記憶卡已滿且內部緩衝記憶體（暫時）已滿，或是
  - 充電電池到達極限值（電力、容量、年限）。
2. 如果將快門鈕按到底，就會完成拍攝動作；若在自拍模式，將會啟動預設的自拍倒數計時。隨後，影像資料會被傳送到記憶卡上。

快門按鈕上有一個快門線用的標準螺紋孔。

**提示：**

- 若已經啟動播放模式（請看第74頁的）或選單操控功能（請看第26頁），則可藉由碰觸快門鈕立即切換回到攝影模式。
- 為了避免手震，應緩緩地按壓快門鈕，直到聽到一聲輕輕的快門響聲為止。
- 也可在拍攝影片模式下操作快門按鈕，單拍一張或多張相片。請看第66頁有關拍攝影片及影片快門按鈕的詳細說明。

## 連續拍攝

您不僅能拍攝單張相片（主開關調到**S** [單張] ），也能執行連續拍攝（主開關調到**C** [連續] ），以多段式地記錄下運動過程。連續拍攝的快門鈕操作方式和單張拍攝相同：若將快門按鈕壓到底並保持在該位置（且記憶卡有足夠的空間），相機就會進行連續拍攝。若只是短促地將快門鈕按到底，相機會進行單張拍攝。

此功能最快每秒可拍攝3張相片。第一次連拍時，會以較快的速度至少連續拍攝16張，之後連拍頻率會變慢。

## 提示：

- 上述拍攝頻率以及連拍張數上限，係基於標準設定：**ISO 320**，**JPEGfine**格式。若採用其他設定，或視所使用記憶卡的不同，頻率及張數可能會減少。
- 若使用連續拍攝功能，不論連拍幾張相片，在兩種播放作業模式（請看第74頁）之下都會先顯示該系列的最後一張相片或者是該系列儲存在記憶卡的最後一張相片 - 除非該系列拍攝的所有相片都從相機內建記憶體轉存到記憶卡了。

## 快門時間設定轉盤

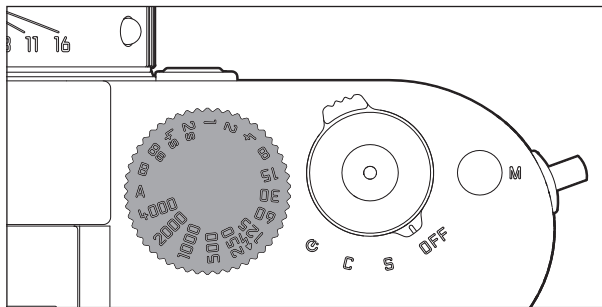

快門時間設定轉盤沒有停止點，可以從任何位置朝任意方向旋轉，可停在所有刻度位置以及其間的數值上，這些停格位置以外的中間位置則無法使用。欲設定出適度的曝光，請參閱從第50頁起的「測光」。

可使用快門時間設定轉盤選擇曝光模式。

- 光圈先決模式，設定到用紅色標示的**A**位置，（請看第52頁），
- 手動模式，讓您選擇快門時間 $1/4000$ 秒至8秒（以 $1/2$ 格為單位的中間值也能使用），
- 用⚡符號另外標示的最短同步時間 $1/180$ 秒，適用於閃光燈模式（請看第64頁），以及
- **B**長時間曝光模式（請看第58頁）。

## 選單操控功能

在相機上，可透過兩個互不相關的選單（請看第116/117頁）進行許多設定。

分為2個選單並在主選單內分門別類後，依經驗最常被使用之選單項目的開啟與設定特別迅速又簡單。

這些選單項目的設定值及其設定步驟，在已開機的相機上可一覽無遺，並且在顯示幕逐步展示說明。

這兩個選單的設定方式基本上是相同的，唯獨開啟和關閉的方式有異。

## 主選單

主選單提供33個項目，並且分為3個功能群組：

- **CAMERA** (相機基本設定 - 菜單頁面1)
- **IMAGE** (攝影設定 - 菜單頁面2)
- **SETUP** (副功能 - 菜單頁面3-5)

## 攝影參數選單

攝影參數選單包含8個項目。除了攝影基本設定外，還有2個和測光及其操控有關的項目，以及一個用來建立和開啟使用者設定檔的項目。

## 設定選單功能

- 用MENU按鈕開啟主選單；用SET按鈕開啟攝影參數選單。
  - 這時主選單上會先出現= CAMERA頁面及前6個項目，在攝影參數選單中會出現所有項目。叫出某選單後，目前開啟的選單項目是上次選取的項目。

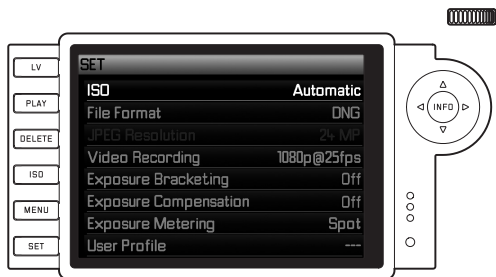
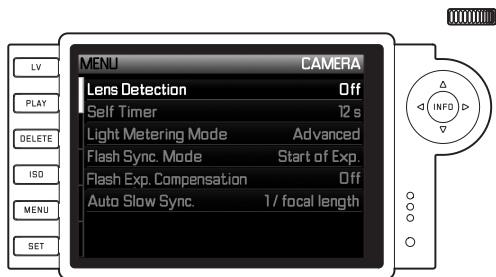

## 提示：

只能從攝影模式進入攝影參數選單

2. 您可以旋轉設定轉盤（往右轉 = 選單往下捲動，往左轉 = 選單往上捲動）或使用上/下十字鍵選擇想要的選單項目。

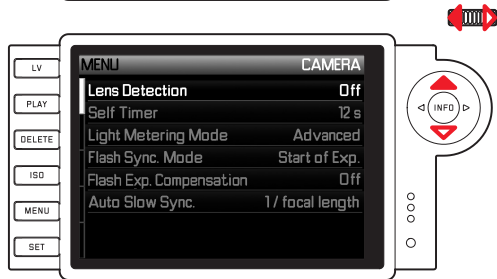
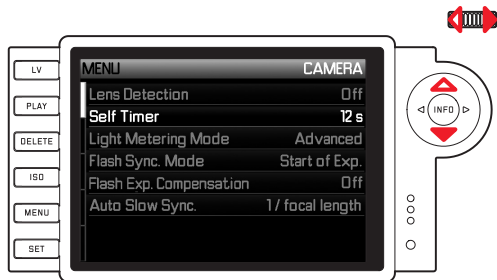

### 提示：

- 在大部分的情況中，使用設定轉盤既方便又迅速。
  - 個別選項項目（如GPS和Format SD card）及某些子選單項目，必須符合一定條件才能啟動。請參閱相關章節的詳細說明。
  - 相關灰色文字行提供參考提示。
3. 可以使用SET或INFO按鈕，或按右十字鍵，啟動相關子選單。
- 頂列會交替顯示以下訊息：左邊黑色區塊顯示選單的功能群組（主選單：**CAMERA**、**IMAGE**或**SETUP**；攝影參數選單僅顯示**SET**），右邊白色區塊顯示啟動的選單項目。子選單通常包含許多不同的功能選項，您可在下一個步驟直接選擇這些選項。在個別應用中會另外出現一個設定數值的刻度尺，否則的話，子選單會提供內含功能選項的子項目供使用者選擇。



4. 接著您可再次旋轉設定轉盤選擇想要的功能選項或數值，或者使用
  - 上/下十字鍵切換不同的行，選擇想要的功能選項
  - 左/右十字鍵設定指定的行或刻度尺
 對於含有可選功能選項的子項目，也可以使用**INFO**按鈕切換不同的行。
  - 頂列會交替顯示以下訊息：左邊黑色區塊顯示子項目，右邊白色區塊顯示叫出的功能選項。

#### 提示：

**Date/Time**等選單項目以及**Exposure bracketing**等功能還需要其他設定。相關說明以及其他選單功能的細節，詳見於相關章節。

5. 用**SET**或**INFO**按鈕儲存您的設定。
  - 顯示畫面切換回初始狀態。功能項目右方會顯現當前被選用的功能選項。

#### 提示：

您可以隨時按壓下列按鈕關閉選單及子選單，而且不會套用之前完成的設定。

	快門按鈕/ 影片快門按鈕	PLAY	MENU
<b>主選單</b>	相機切換至攝影模式	相機切換至播回前一個步驟放模式	相機切換至播回前一個步驟放模式 (如上一次選單)
<b>攝影參數選單</b>	相機切換至攝影模式	相機切換至播回前一個步驟放模式	相機切換至播回前一個步驟放模式 (如上一次選單) 或切換至主選單

## 預設功能

### 相機基本設定

#### 選單語言

相機在出廠前已設定為英文。您可選用其他選單語言，如德文、法文、西班牙文、義大利文、日文、韓文、俄文、繁體中文或簡體中文。

#### 設定該功能

1. 從主選單（請看第26/116頁）選擇 **Language**（第5頁，**SETUP** 區域），然後
2. 從子選單選取您想要的語言。
  - 除了少數例外（按鈕名稱、簡稱），所有選單項目的語言都會隨之更改。

#### 時間和日期

這些數值可在選單項目 **Date/Time** 中設定。

#### 設定該功能

1. 從主選單（請看第26/116頁）選擇 **Date/Time**（第5頁，**SETUP**區域），然後
2. 開啟其子選單。該子選單提供三個項目：**Auto time/time zone**、**Date**及**Time**。

#### 由GPS操控的自動時間顯示

必須安裝多功能M型手把（隨產品提供的配件，請看第96頁），才提供此選單項目。

3. 選擇 **Auto time/time one**。
  - 該子選單還有一個子選單，提供三個項目：**Auto time via GPS**（僅在選單中已啟用**GPS**功能時，才能啟動此項目。請看第69頁）、**Time zone**及**Summer time**。
4. 選擇子選單 **Auto time via GPS**，然後
5. 在此選擇您想要的選項（**ON/OFF**）。  
啟動此功能後，相機內建時脈即依照收到的GPS訊號調整。

### 設定世界任何地點的正確時間：

6. 在同一個子選單裡選擇 **Time zone**，然後
7. 在此選擇您想要的時區/目前所在地點。
  - 該列右邊顯示目前與格林威治標準時間的差異設定、相關時區中的大城市及該城市的時間。

### 設定實施日光節約時間國家的正確時間：

8. 在同一個子選單裡選擇 **Summer time**，然後
9. 在此選擇您想要的選項 (**ON/OFF**)。

### 提示：

**Time zone**及**Summer time** 僅在關閉光圈先決功能後，**Auto time via GPS**使用。

### 日期

您有3種日期顯示模式可選擇。

3. 選擇 **Date / Time**子選單中的 **Date**。由兩個選單項目 **Format**及 **Setting**所組成。
4. 選擇 **Format**。
5. **Format**子選單提供三種可能的順序供選擇：**Day/Month/Year**、**Month/Day/Year**及**Year/Month/Day**。
6. 儲存您的設定。
  - 再次出現 **Date**子選單。
7. 選擇 **Setting**。
  - 另外又出現一個子選單，分別顯示年、月、日數值欄位。已啟用可供設定的欄以紅色底線標示，表頭以白色字體顯示，可設定的數字及名稱以紅色字體顯示。可使用設定轉盤或十字鍵設定數值/月份，亦可使用 **SET**、**INFO**或十字鍵切換欄位。
8. 設定好3個欄位後，請確認並儲存設定。

## 時間

時間顯示格式，可選24小時制或12小時制。

兩組數字以及顯示方式必須在子項目**Time**中設定，其設定方法與前面所述的**Date**設定雷同。

### 提示：

即使相機未裝上充電電池，或是電池沒電，日期和時間的設定仍能仰賴內建備用電池的電力保持約2個月。若超過期限，之後就必須依照以上說明的方式重新設定日期和時間。

## 自動關機

此功能會在預設的時間過後，使相機自行關機。

### 設定該功能

1. 從主選單（請看第26/116頁）選擇**Auto Power Off**（第5頁，**SETUP**區域）。
2. 選擇想要的時間長度。

### 提示：

如果相機處於待機狀態，亦即顯示幕在30秒後消失，或是啟動**Auto Power Off**功能造成相機關機，只要按一下快門就能使相機再度進入工作模式。

## 訊號聲

您可決定在畫面上出現的警告訊息及自拍過程是否另外再以警示音（提供兩種音量供您選擇）提供警示，或讓相機的操作變成無聲。

### 提示：

訊號聲的原廠預設值為**OFF**。

## 設定該功能

1. 從主選單（請看第 26/116頁）選擇**ACOUSTIC SIGNAL**（第5頁，**SETUP**區域）。
2. 接著可選擇**OFF**、**Low volume**或**High volume**。

## 攝影基本設定

### 開啟/關閉鏡頭型號辨識功能

最新徠卡M型鏡頭的接座上有6位元辨識碼，可以讓相機利用其鏡頭接座裡的感測器，辨識出裝上的鏡頭型號。

- 這些資訊有助於改善影像資料。例如使用廣角鏡頭和大光圈時特別明顯的周邊失光現象，就會在影像檔案中作補償修正。
- 閃光曝光及閃光反射罩的控制，也會用到鏡頭資料（請看第60頁「可用的閃光燈」）。
- 除此之外，這些6位元辨識碼提供的資訊，會記錄在相片的EXIF檔案。在擴大說明的相片資料裡，會額外顯示鏡頭焦距（請看第110頁）。

### 設定該功能

1. 從主選單（請看第26/116頁）選擇 **Lens Detection**（第1頁，**CAMERA**區域），然後
2. 在附屬的子選單選擇想要的項目：
  - **OFF**，或是
  - **Automatic**（如果安裝上的鏡頭有辨識碼），或是
  - **Manual**（如果裝上無辨識碼鏡頭）。

### 提示：

使用不含6位元辨識碼的鏡頭時必須將辨識功能關閉，以避免發生故障。您也可以將您使用的鏡頭型號手動輸入（請看第34頁）。

### 手動輸入鏡頭型號/焦距

本機無法辨識舊款缺少辨識碼的徠卡M型鏡頭，但可透過功能選單執行「辨識」動作。

徠卡R鏡頭也是一樣，但在相機上加裝徠卡R轉接頭M後，便可使用（請參閱轉接頭使用手冊的詳細說明）。

3. 從 **Manual** 子選單的清單選取您所使用的鏡頭。
  - 顯示畫面會顯示一份鏡頭清單。為了方便辨識，清單中也包含各個鏡頭的料號。機會辨識是否安裝M型鏡頭或使用轉接頭安裝徠卡R鏡頭。清單會相應地只顯示M型或R型鏡頭。

### 提示：

- 鏡頭料號通常蝕刻在焦距刻度表的對面。
- 該清單包含沒有辨識碼的鏡頭（大約2006年6月以前的款式），推出日期較新的鏡頭都有辨識碼，所以無法手動選取。
- 使用徠卡 TRI-ELMAR-M 1:4/16-18-21mm ASPH. 鏡頭時，焦距的設定無法傳送到相機，因此無法記錄在相片的EXIF資料中。不過，有需要時，您可手動輸入當時所用的焦距。
- 徠卡 Tri-Elmar-M 1: 4/28-35-50mm ASPH 具備連動觀景窗內取景框線的必要機械式傳導功能，可將設定的焦距傳給相機，讓相機電子系統得以感測，並針對該焦距進行必要的修正。因為空間不足，選單中只會列出一個料號——11 625。另外兩個號碼——11 890和11 894——當然也可使用；您在選單中所進行的設定對它們當然也有效。

## 漸暈修正

漸暈在攝影技術中標示影像從中心軸到邊緣的光強度漸弱。所有鏡頭以不同的方式展示該效應，特別是在光圈全開和光強度高的情況下。如果相機能夠辨識出裝上的鏡頭型號，則可以部分補償該效應。

如果需要將漸暈效應用作設計元素，則可以禁用該修正功能。

## 設定該功能

1. 從主選單（請看第 26/116頁）（第2頁，**IMAGE**區域）選擇**Shading correction**，然後
2. 在附屬的子選單選擇想要的項目（**ON** / **OFF**）。

## 檔案格式

影像資料的儲存格式有如下幾種選擇

- a. 檔案格式 **JPEG**：- **JPEG fine**，或是
- b. 壓縮或不壓縮的資料格式**DNG**，或是
- c. 結合**JPEG fine**和**DNG**格式，亦即每拍一張相片就會產生兩個檔案。

可配合使用者預定的使用目的及記憶卡的容量，另外一方面，亦可為事後才決定的可能變更，保留必要的彈性。

## 設定該功能

### 選擇格式 / 格式組合

1. 在攝影參數選單裡（請看第26/116頁）選擇**File format**，然後
2. 在附屬子選單選擇想要的格式 / 格式組合。

## 選擇DNG壓縮

1. 從主選單（請看第26/116頁）選擇 **DNG compression**（第2頁，**IMAGE**區域），然後
2. 在附屬的子選單中選擇想要的選項（**ON** [=壓縮]/**OFF** [=不壓縮]）。

### 提示：

- 相機儲存完全未經處理的攝影原始資料時，會使用標準化的DNG (Digital Negative, 數位負片) 格式。
- DNG格式的壓縮
  - 無損失，也就是不會造成品質損失。
  - 允許事後各種影像檔案處理
  - 儲存迅速
  - 所需的儲存空間也較少。
- 同時將相片資料儲存為DNG和JPEG時，JPEG格式會套用當時的解析度設定，所以兩個檔案解析度可能不同。
- 顯示幕並不會在每次拍攝之後顯示剩下張數，而是視拍攝主題而定。是否會更改，與您所攝影的主題有些關聯；非常細緻的結構會產生較大的JPEG檔案，均質畫面所產生的檔案則較小。

## 解析度

影像檔案在JPEG格式中可用四種不同的解析度加以記錄。您可配合記憶卡容量及預定的用途運用此功能。若選用最高解析度（資料量自然也最大）——例如為了列印大幅高品質的相片——，記憶卡所能儲存的相片總數，就會比選用最小解析度時要少得多。

### 設定該功能

1. 在攝影參數選單裡（請看第26/116頁）選擇 **JPEG resolution**，然後
2. 在附屬子選單選擇想要的解析度。

### 提示：

不論JPEG格式的設定是否有所不同，DNG格式都提供24MP的基本解析度。



## ISO感光度

ISO設定範圍是ISO 320 - ISO12500，設定單位 $1/3$ 級數，以便您依攝影當時的快門時間 / 光圈值條件手動調整出適當的設定。此外，還可設置**Push 25000**，相當於ISO 25000的感光度。

除了固定設定選項外，相機還提供**Auto**<sup>1</sup>功能，讓相機自動配合外界亮度，或預先設定的快門時間 / 光圈值條件調整感光度。

如此連同光圈先決功能（請看第52頁），可大幅擴充自動曝光操控的範圍。手動設定模式提供更多快門時間 / 光圈組合應用選擇，能充分滿足您的需要。

您也可以，例如基於構圖緣由，在此功能內訂定優先次序。

### 提示：

特別是在高ISO感光度及影像後處理的情形下，有可能在被攝目標的大面積均勻亮區看到雜訊，以及垂直和水平條紋。

## 設定該功能

### 使用ISO按鈕

1. 按下ISO-按鈕。
  - 相關子選單會出現在顯示幕上。
2. 按住ISO按鈕的同時，用設定轉盤選擇想要的感光度或是自動設定。

### 提示：

放開ISO按鈕之後，子選單會繼續顯示約2秒鐘。設定值會立即套用。

### 使用選單操控

1. 在攝影參數選單裡（請看第26116/**ISO**），然後
2. 使用設定轉盤或按壓上/下十字鍵選擇想要的感光度或是自動設定。
3. 按一下SET或INFO按鈕，確認您的設定。

### 如果要使用自動設定感光度的功能

3. 在步驟2選擇**Auto**。
  - 子選單中原本灰化（也就是無法使用）的項目變成啟用。

<sup>1</sup> 使用閃光燈時，此功能無法使用。

**提示：**

原廠預設為Maximum ISO功能以ISO 12500為限。

**如果要限制自動設定的有效範圍**

- 在此子選單選取Maximum AUTO ISO 以及 / 或Maximum exposure time。
- 在Maximum AUTO ISO子選單中選擇將使用的最大感光度，以及自動設定功能的適用範圍，或者從Maximum exposure time子選單的三個焦距相關設定 $1/focal\ length$ 、 $1/2xfocal\ length$ 、 $1/4xfocal\ length$ 中，選擇一個設定<sup>2</sup>（若要確保相機在快門時間內不發生手震），或者按照自己的需要選擇最長的快門時間（ $1/2$ 秒 -  $1/500$ 秒；無段）。在焦距相關設定中，當快門時間因為光線較弱而降至閾值以下時，相機便會切換至更高的感光度。例如使用50mm鏡頭時， $1/focal\ length$ 切換至 $1/60$ 秒以上， $1/2xfocal\ length$ 切換至 $1/125$ 秒以上， $1/4xfocal\ length$ 切換至 $1/250$ 秒以上。
- 按一下SET或INFO按鈕，確認您的設定。

**在手動曝光設定模式下確定AUTO ISO運作方式**

- 在此子選單選擇AUTO ISO in M mode，然後選擇On或Previous ISO。
- 在On功能項目下進行自動操控（可能須受限於您在子選單項目Maximum AUTO ISO中的設定）。在前一次Previous ISO功能項目下套用上一次手動設定的感光度。
- 按一下SET或INFO按鈕，確認您的設定。

**提示：**

使用自動包圍曝光功能（請看第56頁）時，請遵守以下規則：相機自動為無曝光補償攝影所設定的感光度也會用在這一系列攝影的其他拍攝中；換句話說，該ISO值在這一系列攝影中不會更動。可能會導致超過Maximum exposure time提供的最長快門時間。

<sup>2</sup>使用此功能的前提是要安裝有辨識碼的鏡頭，或在選單中設定所使用的鏡頭型號（請看第34頁）。

下列兩個章節所描述的功能與設定適用於使用JPEG格式的攝影。如果預先選用了兩種DNG檔案格式之一，這些特性的設定無效。因為這種情形下的影像檔案，基本上是以原始形式儲存的。

## 影像特性／對比、銳利度

使用電子攝影可輕易改變影像特性。這類修改工作大多可以在攝影完後，在電腦上使用影像處理軟體進行。相機卻可讓您在攝影前，就能先左右兩項主要影像特性：

- 對比，也就是亮區和暗區之間的區別，決定一張相片看起來「平淡」或「生動」。放大或縮小此差異，亦即讓亮的部分顯得更亮、暗的部分顯得更暗，即能更改整體影像的對比。
- 正確的對焦（至少對拍攝主題）以獲得銳利影像，是成功攝影的先決條件。話說回來，影像輪廓邊緣的清晰度，亦即影像輪廓邊緣的亮/暗過渡區的大小，對該影像所呈現的清晰感有很大的影響。因此，擴大或縮小這些區域，即能改變影像所呈現的清晰感。所有三項影像特性全都能個別在選單進行設定；每一項都有五段設定級數供您選擇，讓您能針對現場光線條件進行調整，以獲得最佳影像效果。

## 設定該功能

1. 從主選單（請看第 26/116頁）選擇 **Sharpness**、**Contrast**（**IMAGE**區域），然後
2. 在相應的子選單中選擇想要的級數。

## 色調

色調在黑白攝影中始終是一個受歡迎的風格工具。對黑白攝影的輕度“著色”能夠產生另一種特性。這樣的話，棕色色調可以產生一種“古典”的效果，藍色色調則會產生冷感效果。徠卡 M Monochrom 能夠為您提供三種調色效果，每種色調兩種強度。

## 設定該功能

1. 從主選單（請看第26/116頁）選擇 **Toning**，
2. 在附屬的子選單中選擇想要的調色形式 - **Hue** 或 **Strength**，然後
3. 從相關子選單選擇想要的設置，即在 **Hue** 中選擇色調（**Sepia**、**Blue**或**Selenium**，在 **Strength** 中選擇色飽和度（**Off**、**Weak**或**Strong**）。

## 取景框線－測距觀景窗

此相機的有框線觀景窗，不只是一個品質特高、尺寸特大、卓越明亮的觀景窗，也是一個和鏡頭連動、非常精確的測距儀，此觀景窗能和相機上16到135mm焦距的所有鏡頭搭配使用，且為自動配合。觀景窗擁有0.68倍的放大倍率。

如果裝上焦距為28（出廠序號從2 411 001起的Elmarit）、35、50、75、90和135mm的鏡頭，則會自動套用所屬以LED照明的28+90mm、35+135mm、50+75mm取景框線組合。可選擇紅光或白光照明。此照明可在任何光線條件及主題下提供最佳的辨識。

## 選擇取景框線的顏色

1. 從主選單（請看第 26/116頁）選擇**Frameline Color**（第3頁，**SETUP**區域），然後
2. 在附屬的子選單裡選擇想要的顏色。

取景框線的尺寸相當於感測器的尺寸，例如2m距離設定下的感測器尺寸為23.9 x 35.8mm。本取景框線的尺寸是配合徠卡M 原廠預設的格式而定，讓取景框線和距離設定是連動，視差－也就是鏡頭和觀景窗軸線之間的偏差，會自動補償修正。感測器能感測到的比取景框線內緣顯示在距離小於2m以內時小一點，距離超過2m時則多一點（請看旁邊的圖解），這些在實務中鮮少被注意到的細微差異源自作業原理：

運動測距式相機的取景框線必須配合所用鏡頭焦距的視角調整。然而在對焦時，額定視角會隨著變化中的外移量而變，亦即隨光學系統和感測器平面之間的距離而變。如果設定的焦距比無限遠小（相對的，外移量較大），實際上的視角也會比較小－鏡頭能掌握到的攝影目標較少。此外，焦距較長時的視角差異有隨著較大的外移量變大的傾向。

在觀景窗區域的中央有四邊形的對焦區，比周圍的影像區域亮。若啟動了測光表，觀景窗影像下緣就會額外出現測光表的LED訊號或LED閃光燈符號。

關於測距、測光以及閃光燈作業的進一步說明，請看第46/50/60/頁的相關章節。

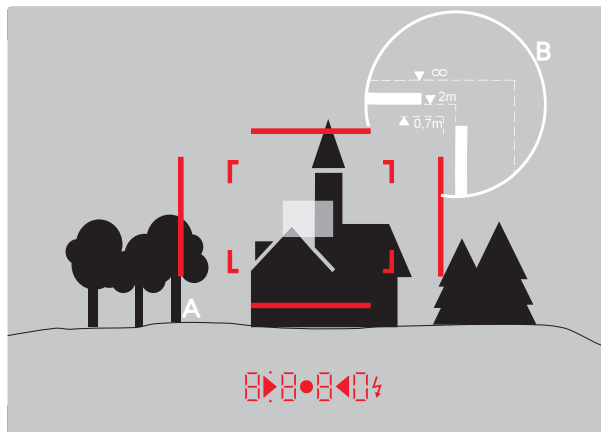

所有相片和取景框線位置都以50mm的焦距為基準

A	取景框線
B	實際畫面
設定為0.7m時：	感測器取得的景象略微小一點，其差異約為框線線寬。
設定為2m時：	感測器取得的景象與取景框線內緣所顯示的畫面吻合。
設定為無限遠時：	感光元件可涵蓋大約1(垂直)/4(水平)的框線寬度。

## 視野撥桿

視野撥桿擴展了此一內建泛用觀景窗的應用可能性。您可隨時讓觀景窗映出不屬於所裝鏡頭的取景框線。您可藉此判斷，是否使用別的焦距拍攝當時的拍攝主題，能得到更好的構圖。

如果將撥桿向外撥，亦即朝遠離鏡頭的方向轉動，則會出現適用於35mm和135mm焦距的取景範圍。

如果將撥桿撥至中間垂直位置，則會出現適用於50mm和75mm焦距的取景範圍。如果將撥桿往內撥，亦即朝鏡頭的方向轉動，則會出現適用於28mm和90mm焦距的取景範圍。

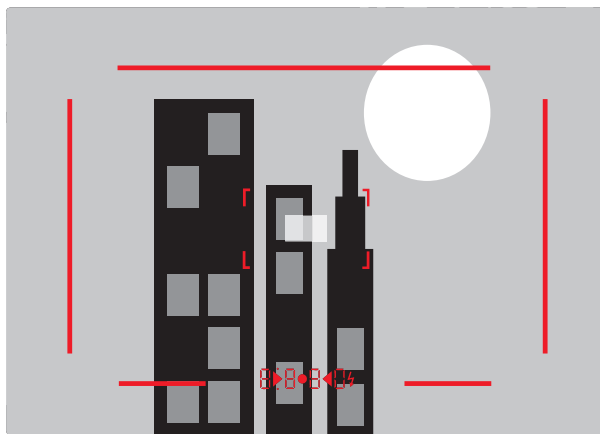

35mm + 135mm

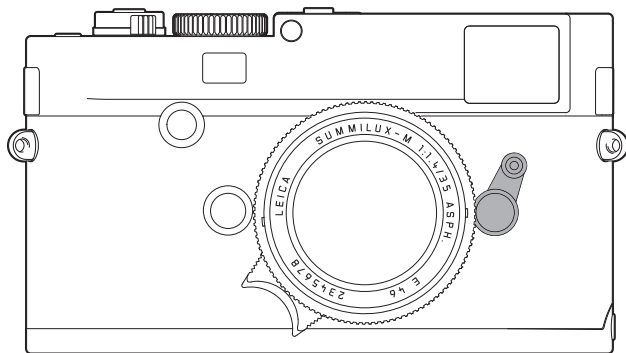

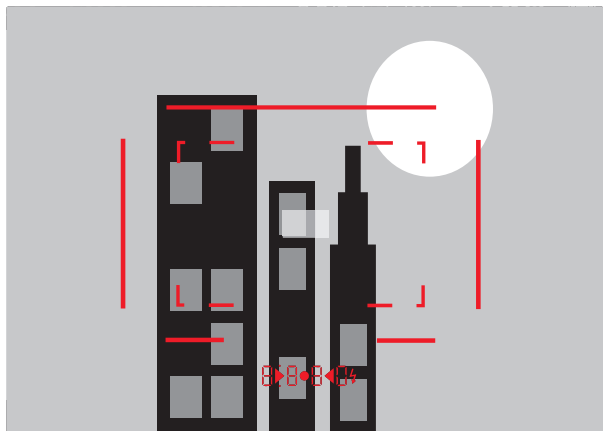

50mm + 75mm

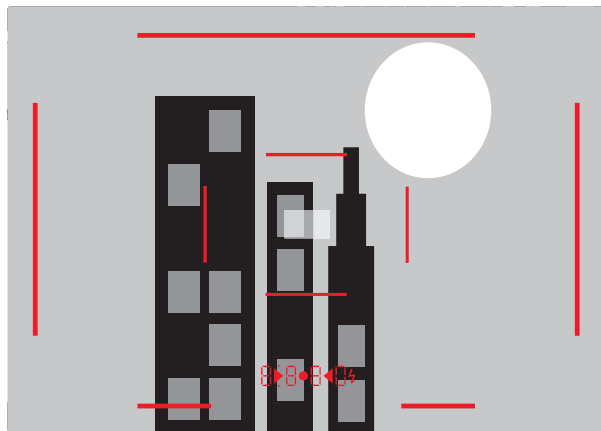

28mm + 90mm

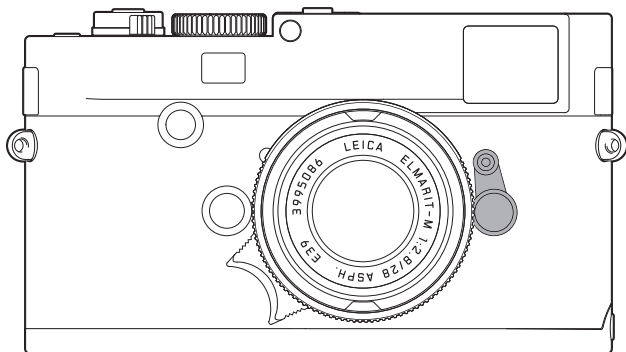
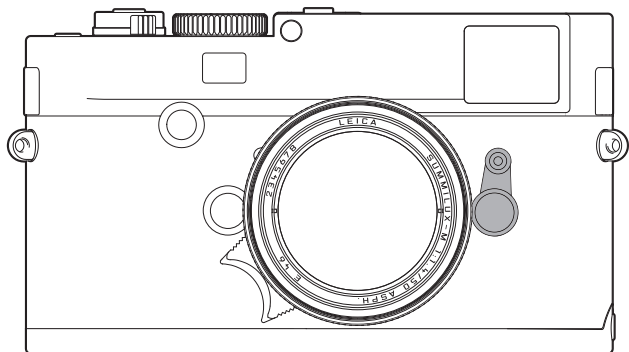

## 顯示螢幕

相機配備一個大吋3" 液晶屏幕，通過一塊由超強、耐刮的藍寶石玻璃製成的保護玻璃遮擋防護。在攝影模式下啟動實時取景功能時，顯示幕上會顯示由感測器透過鏡頭捕捉的畫面。在播放模式下，可在顯示幕上觀賞儲存在記憶卡內的相片。在前述兩種模式下都會顯示整個影像區及所選的數據與資訊（請看第110頁）。

## 設定亮度

顯示幕的高度可透過選單調整。可選擇自動（依外界光線自動控制）及五段式手動控制，讓您能針對現場條件進行調整，以獲得最佳影像效果。

1. 從主選單（請看第 26/116頁）選擇**Monitor** **brightness**（第3頁，**SETUP**區域），然後
2. 在子選單選擇自動設定或五段手動設定。

### 提示：

- 除了選單操控（請看第26頁）外，您可以在加裝的電子觀景窗（例如隨產品提供的徠卡 EVF2，請看第94頁）上檢視本說明書所述的所有顯示訊息（可選擇）。
- 可使用選項**EVF brightness**（**選單**，第3頁，**SETUP**區域，請看第 26/116頁），以如上所述之相同方式設定觀景窗的亮度。

## 實時取景模式

此相機的實時取景模式下，可在攝影時於顯示幕上檢視主題，其畫面與鏡頭捕捉到的完全相同。此模式為使用特定銳利度設定方法（請看第48頁）及測光方法（請看第50頁）的先決條件。使用**LV**按鈕開啟/關閉實時取景模式。若要確保不會因為意外而啟動實時取景模式，可以關閉**LV**按鈕。

## 開啟/關閉LV按鈕功能

1. 從主選單（請看第26/116頁）選擇**Focus Aid** **SETUP**（第1頁，**CAMERA**區域），然後
2. 在所屬的子選單中選擇 **Classic/LV deactivated**。

## 實時取景螢幕畫面的亮度

本機提供兩種模式。在半按快門的出廠設定下，亮度取決於快門的操作。

1. 按下快門打開測光系統，然後再次放開：
  - 拍攝主題
    - 受到目前所使用曝光作業模式（光圈先決 / 手動設定）
    - 不會受到預先設定的快門時間 / 光圈值的影響，預先設定之快門時間 / 光圈值條件的影響。
  - 此設定在
    - 主題亮度及曝光亮度設定值不會太高或太低，而且
    - 所測量的曝光時間不會過長。



2. 按下快門至第一個壓點：  
螢幕畫面的亮度即與當時的曝光亮度設定相同。您可藉此功能在拍攝前，判斷由當時曝光設定所決定的相片畫面效果。

如果將快門鈕按至第一壓力點，則螢幕畫面的亮度即與當時的曝光亮度設定相同。您可藉此功能在拍攝前，判斷由當時曝光設定所決定的相片畫面效果。第二個模式**Continuous**僅限手動曝光設定時使用。基本上，此模式會在螢幕畫面上以亮暗方式顯示快門時間和光圈的設定效果。

### 設定該功能

1. 從主選單（請看第26/116頁）選擇**Exposure simulation**（第4頁，**SETUP**區域）。
2. 開啟其子選單，然後
3. 從子選單中選擇適用於第一種模式的 **Shutter release half pressed**，或適用於第二種模式的**Continuous**。

在標準設定下，實時取景顯示幕會在頂列顯示一些基本資訊。可使用**INFO**按鈕叫出其他兩個顯示詳細資訊的圖示（請看第110頁）。您可在第一個圖示中額外顯示適用於長寬比1:4、6:7或16:9的取景框線。之後進行局部畫面構圖時，將更加容易。可藉由按壓上 / 下十字鍵的方式，依序叫出取景框線。

### 水平儀

啟動此功能時，會出現第三個圖示和水平顯示訊息。相機可藉由整合式感測器和此顯示訊息調整方位。顯示幕上的顯示能夠在進行嚴格要求方位準確性的攝影時協助您，例如用腳架進行建築攝影時，可以精準設定相機在縱軸及橫軸上的方位。

### 開啟／關閉水平方位

1. 從主選單（請看第26/116頁）選擇**Horizon**（第4頁，**SETUP**區域）。
2. 開啟其子選單，然後
3. 從子選單中選擇**ON**或**OFF**。
  - 監控螢幕會在第四個實時取景視圖中出現一垂直刻度尺與一水平橫軸。偏離各軸零位者，有紅色圖示；縱軸與橫軸的水平方位則有位於中央的綠色圖示。

### 提示：

- 實時取景模式係以感測器捕捉到的畫面為依據。為此必須開啟快門；當功能中斷時，快門隨即關閉。快門關閉時會聽到關閉聲音，且快門操作可能會有些延遲。
- 頻繁使用實時取景模式會耗用較高的電力。
- 許多光源的交流電流都會造成人眼看不到的亮度波動變化。螢幕畫面可能因畫面感測器的敏感度和讀取頻率而產生閃爍現象，或是錄影畫面上的條紋（照片上沒有這種現象）。選擇較長的快門時間可以避免這種錄影時的效應。

## 測距

此相機提供多種距離設定輔助方法，可視相機內建、光學觀景窗及 / 或實時取景模式（請看第44頁）等不同用途，而選擇正確的方法。

### 提示：

- 電子顯示訊息以感測器捕捉到的畫面為依據。為此必須開啟快門；當功能中斷時，快門隨即關閉。快門關閉時會聽到關閉聲音，且快門操作可能會有些延遲。頻繁使用此功能會耗用較高的電力。
- 由於感光度及功能條件的不同，所顯示的感光設定與實際感光之間可能有所差異。

## 使用光學測距儀

此相機的測距儀，由於有效基線很大，可以非常精準地作業。特別是在使用廣角鏡頭時，因為景深相對來說很大，其優點會更加顯著。

機械基線 (觀景窗和測距儀觀測窗的光學軸之間的距離)	x 觀景窗 放大倍率	= 有效基線 測量基線
69.25mm	x 0.68	= 大約 47.1mm

測距儀的對焦區在觀景窗的中央，是一個明亮及清晰的方塊區。您可用混合影像法或分割影像法進行對焦：

## 混合影像法（雙重影像）

在拍攝人像時，例如把測距儀的對焦區瞄準眼睛，然後持續轉動鏡頭上的對焦環，直到對焦區裡的輪廓疊合為止。隨後再設定拍攝主題的構圖範圍。



不清晰

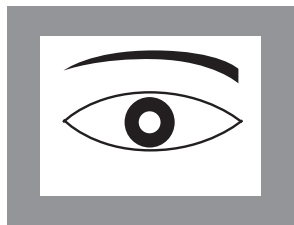

清晰

## 分割影像法

拍攝建築物時，例如用測距儀的對焦區瞄準垂直邊緣或別條清楚定義的垂直線，然後一直轉動鏡頭的對焦環，直到邊緣的輪廓或線條和對焦區的邊界呈現無錯位為止。隨後再設定拍攝主題的構圖範圍。

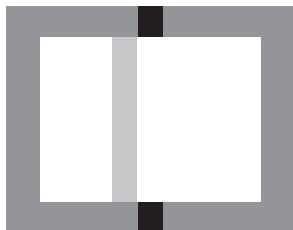

不清晰

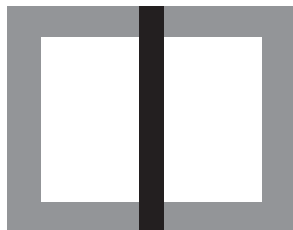

清晰

## 測距 (續)

### 提示：

以下兩項功能亦適用於徠卡R型鏡頭，也就不只是適用於有6位元辨識碼的徠卡M型鏡頭及徠卡M型鏡頭（皆可從選單選取）。

### 在實時取景模式下使用顯示幕

在實時取景模式（請看第44頁）下，可藉助顯示幕完成設定，所顯示的主題銳利度和鏡頭在距離及光圈設定條件下所呈現的銳利度完全相同。

### 步驟

1. 使用LV-按鈕啟動實時取景模式。
2. 使用鏡頭的對焦設定環設定所需的主題銳利度。

為了方便設定或提高設定準確度，可將顯示幕上的中間局部畫面放大。可用兩種方式啟動此功能。

### 偶而使用：

1. 按下對焦按鈕。
  - 顯示幕顯示
    - 放大的畫面
    - 設定轉盤符號及可能的放大/縮小方向
    - 目前放大倍率。可使用設定轉盤改變放大倍率（5x或10x）。
2. 使用鏡頭的對焦設定環設定所需的主題銳利度。

### 長時間使用：

1. 從主選單（請看第 26/116頁）選擇**Focus Aid**（第3頁，**SETUP**區域），然後
2. 從所屬的子選單選擇**Automatic**。
  - 一旦轉動鏡頭的對焦設定環，隨即顯示上述放大的畫面。可以隨時輕按快門鈕回到正常（即未放大的）圖示。可使用設定轉盤視需要改變放大，或在全螢幕畫面開啟未放大的1x視圖。

## 顯示幕上的銳利主題成像標示

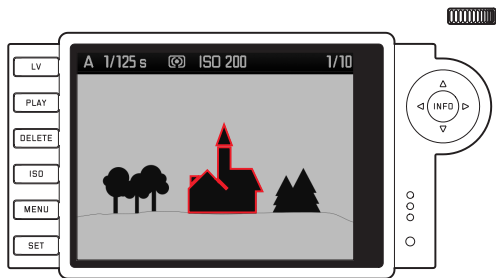

可在實時取景模式下，於顯示幕上標示最佳銳利主題成像部位，以利辨識。相機提供的三種顏色可搭配不同的環境光線選用。

## 步驟

1. 從主選單（請看第 26/116 頁）選擇 **Focus Peaking**（第 3 頁，**SETUP** 區域），然後
2. 從所屬的子選單選擇 **Red**、**Blue** 或 **Green**。若不需要使用此功能，**Off** 關。
3. 使用 **LV**-按鈕啟動實時取景模式。
4. 指定取景範圍。
5. 按下對焦按鈕或轉動鏡頭的對焦設定，標示想要的主題部位。
  - 所有經過對距而呈現銳利影像的主題部位，以框線（顏色自行選定）標示。

## 重要：

此功能以主題對比（即明暗差異）為依據。因此，也可能會標示未銳利成像但對比強烈的主題部位。

## 開啟/關閉測光表

測光表在輕按快門按鈕時啟動，但在此之前，要先用主開關將相機關機，而且快門時間轉盤不是設定在B的位置。

觀景窗或顯示幕上的訊號持續發亮，代表測光表已就緒：

- 使用光圈先決時，快門時間的LED訊號
- 使用手動設定時，觀景窗兩個三角形LED中的其中一個LED，有時候中間的圓形LED也會派上用場，或顯示幕上出現光量計。

若放開快門按鈕，而沒有啟動快門，測光表會繼續維持約30秒長的啟動狀態，而且相關的LED會繼續發亮。快門時間轉盤調至B時，測光表處於關閉狀態。

提示：

- 如果不可能在光圈先決模式下以現有的快門時間得到正確的曝光，則快門時間顯示訊息會閃爍表示警告(僅適用於觀景窗；相關詳細內容請看第52頁的「光圈先決」)。
- 若測光表的測光區處於手動設定模式，而且低於非常低的光線密度，則觀景窗左邊的三角形LED會閃爍(或顯示幕光量計左邊的破折號)表示警告。在光圈先決模式中，快門時間會繼續顯示。如果所需快門時間超過60秒的上限，在觀景窗內該訊號也會閃爍。

- 相機長時間不使用或是放在相機袋裡時，應該要用主開關關機。藉此也可防止不經意按壓到快門鈕而攝入影像的意外發生。

## 測光方法

此相機提供兩種測光方法：

- **Classic**模式的中央重點測光。這種測光法會考量整個影像區範圍，不過位於中間的拍攝主題在計算曝光值時所佔的比重比邊緣區域大很多。
- 一顆光電二極體會接收並測量從第一道快門簾幕上淺色的快門葉片反射來的光線。
- **Advanced**模式或實時取景模式(請看第44頁)下可選擇點測光、中央重點式測光及多區測光。先決條件是必須在攝影感測器上測光。

## 非實時取景模式的必要預設

1. 從主選單（請看第26/116頁）選擇 **Exposure metering**（第1頁，**CAMERA**區域），然後
2. 在附屬的子選單裡選擇
  - **Classic** 快門測光，適用於上述常用的測光方法，或是
  - **Advanced** 感測器測光（當您需要從以下三個測光方法中選擇時）。

### 提示：

- 即使設定為 **Classic**，實時取景模式原則上仍然提供以下三種測光方法。
- 若選擇第三個子選單選項 **Classic/ LV deactivated**，LV 按鈕功能隨即關閉。

## 選擇測光方法

1. 從攝影參數選單（請看第26/116頁）選擇 **Exposure Metering**，然後
2. 在附屬子選單裡選擇想要的測量方法：
  - **Spot** 僅對畫面中央的一個小區域進行測光。該區域會以顯示幕中間的方塊標示。
  - **Center-weighted** 類似上述 **Classic** -- 中央重點測光。
  - **Multi-field** 這種測光方法是以多個測光值為基礎。這些測光值會置入一個情況演算法進行運算，並得出一個曝光值，該值旨在適當重現主要攝影主題的影像。
- 設定的測光方法會在實時取景及影片模式下顯示於顯示幕，或以放大的 (**INFO**) 訊息顯示（請看第110頁）。

### 提示：

- 必須開啟快門才能執行以影像感測器為基礎的測光方法。此功能中斷時快門隨即關閉。門關閉時會聽到關閉聲音，且快門操作可能會有些延遲。
- 頻繁使用實時取景模式會耗用較高的電力。

為了正確曝光而調整的快門時間，或正確曝光設定的差異值會以觀景窗或顯示幕上的訊息顯示（請參閱以下說明）。

## 曝光模式

此相機提供兩種曝光模式：光圈先決或手動設定。您可依拍攝主題、場合和個人偏好選擇

- 常見的「半自動化」，或是
- 預設的快門時間和光圈。

### 光圈先決

快門時間轉盤設定在A位置時，相機的電子系統會自動設定適當的快門時間—介於 $1/4000$ 秒至32秒之間的任意值，是依預設的感光度、相機測得的亮度和手動選定的光圈而定。為求一目了然，相機計算出的快門時間數值以半階為顯示單位。

曝光時間若大於2秒，按下快門後，觀景窗會顯示倒數剩下的曝光時間。不過，相機所計算出、無段調整的曝光時間，可能會和以半階單位顯示的數值略有差異。例如按下快門前，顯示訊息裡看到的值是16（離實際值最近的值），但是計算設定的時間值其實更大，這時按下快門後的倒數計時可能會從19開始。

在極端的光線條件下，測光機制計算所有參數後，可能得到超出運作範圍以外的快門時間，亦即<sup>1</sup>配合亮度值的條件，曝光時間可能必須小於 $1/4000$ 秒或大於60秒。在這種情形下，相機會採用額定的最小或最大的快門時間值，並讓這些數值在觀景窗閃爍以示警告。

### 提示：

- 如第37頁ISO感光度設定的總結所述，使用較高感光度時，您會察覺到或多或少的畫面雜訊——均勻、黑暗的表面上尤甚。為了減少這些令人困擾的現象，相機在以較長的快門時間拍攝之後，會自動產生第二張「黑相片」（快門關閉）。隨之相機會從原先拍攝的影像資料，以數學運算法「消掉」在此平行攝影中所測得的雜訊。在這些情況下，顯示幕會顯示Noise reduction 12s<sup>1</sup>訊息作為提示。進行長時間曝光時，請務必考量這種作業所衍生的雙倍「曝光」時間。在這段時間內，不可以讓相機關機。
- 如果同時使用B快門功能和自拍器（請看第58頁），不能按住快門鈕不放；快門會一直保持開啟狀態，直到第二次按下快門鈕為止（符合T功能）。

<sup>1</sup>此時間值僅為範例



## 測光值儲存

重要的拍攝主題，往往基於構圖的理由並不在畫面中心，而且有時候這些重要的拍攝主題，也比整個畫面的平均值來得較亮或較暗。相機的中間重點式測光及點測光主要只注意畫面中央的區域，而且是依平均灰度值校正。

上面說明的拍攝主題和狀況，在使用光圈先決功能時可輕易用測量值儲存功能克服。

### 提示：

- 測光值儲存功能對多區測光不具意義，因為該測光不以唯一的主題部位為測光目標。
- 實時取景另外還提供一種曝光模擬功能與測光值儲存功能（將快門鈕按至第一壓力點）搭配使用（請看第44頁）。

## 使用測光功能

1. 對準重要的主題部位（若為點測光，則使用對焦區對準），然後再轉向另一個有平均亮度的細部。
2. 接著按壓快門按鈕到第1個壓力點，進行測光及儲存。一直按在該壓點時，觀景窗數字列的上方會出現一個小紅點以示確認，而且快門時間顯示值即使亮度條件產生變化亦不會改變。顯示幕的ISO與曝光修正值之間會出現一個點。
3. 隨之用原先計算出的曝光值進行拍攝。
4. 成功儲存測量值之後，

改變光圈設定並不會讓快門時間跟著變動，亦即有可能產生不當的曝光。手指一旦離開快門按鈕的壓力點，儲存值就會失效。

## 曝光修正

測光表是以一個中度灰色值為基值（18%反射率），相當於一般常見拍攝主題的亮度。如果拍攝主題細部不符合此先決條件，您可採取因應的曝光修正措施。

例如基於特定理由，做一系列拍攝時想刻意拍出有點不足或有點過頭的曝光效果，這時曝光修正便是極為有益的功能。此功能一旦啟動，和測量值儲存功能剛好相反，會一直維持到被重設為止。相機所支援的曝光修正值範圍是 $\pm 3EV$ ，單位是 $\frac{1}{3}EV$ （EV：Exposure Value = 曝光值）。

## 輸入及刪除曝光修正值

相機提供兩種方式可用於調整設定曝光修正值：可透過選單操控或使用設定轉盤（必須先啟用此功能）完成設定。

若您在連續攝影前已打算要對拍攝主題進行偏弱/偏強的曝光，建議您使用功能選單進行設定。使用設定轉盤能迅速進行設定，適用於突發意外狀況，讓您無須中斷用觀景窗追蹤拍攝主題的動作。

## A.藉由選單操控

1. 從攝影參數選單（請看第26/116頁）選擇 **Exposure Compensation**。
  - 監控螢幕會出現一刻度尺以及一個紅色的EV值，其上方有一個白色三角形標示當前的設定。若那些數值都是0，這表示該功能處於關閉狀態。
2. 設定您想要的值。
  - 在輸出選單清單裡會將設定的包圍曝光，以 **EV+/-X** 的型式顯示。

## B.使用設定轉盤

使用設定轉盤時，有兩種方式可用於完成設定。這兩種方式可讓您更快速地完成調整，或避免意外設定。

1. 在攝影參數選單裡（請看第26/116頁）選擇 **Exposure Compensation**，然後
2. 按上 / 下十字鍵，叫出 **Direct adjustment** 選項。
3. 若要使用設定轉盤快速完成設定，請選擇 **On**；若要防止意外設定，請選擇 **Off**。

若選擇 **Off**：

4. 使用設定轉盤設定想要的修正值。

若選擇 **Off**：

4. 按住對焦按鈕，然後用設定轉盤設定想要的修正值。
  - 觀景窗內的修正值做相應變動，如 **1.0/-0.3**，顯示幕上（在實時取景模式下）出現修正值及依該修正值產生及變動的快門時間。

### 重要：

在相機上設定的曝光修正值只會影響現場光線下的測光，亦即不會影響閃光燈的測量（關於閃光燈攝影的進一步細節請參閱從第60頁起的章節）。

不論您用何種方式輸入，以下皆適用於設定的修正值：

- 些修正值在被手動重設為0之前，不會失效，而且不論相機在此期間是否關閉後又重新開啟。
- 這些修正值可用選單或設定轉盤重設。
- 修正值會以EV值格式顯示在攝影參數選單（或在實時取景模式下顯示在螢幕畫面上、以改變後的快門時間格式或底部閃爍點顯示在觀景窗內，或將快門鈕按至第一壓力點啟動顯示訊息後，顯示約0.5秒。

<sup>1</sup>不論加號或減號，「± X」為當前的修正值

## 自動包圍曝光

許多誘人的攝影目標對比都很強烈，也就是說裡面有不是很亮就是很暗的區域，隨著您依什麼部位決定曝光值而異，相片畫面效果會大不相同。面對這類情況時，可啟動光圈先決功能並使用自動包圍曝光功能，讓徠卡M Monochrom型相機拍攝數張曝光級數不同的相片，亦即用不同的快門時間拍攝。隨後您可挑選最合適的相片，或是用適當的影像處理軟體算出一張對比範圍最高的相片（關鍵字HDR）。

您有下列選項可用：

- 四種間隔級數：0.5EV、1EV、2EV及3EV
- 兩種拍攝張數：3或5

## 設定該功能

1. 從攝影參數選單（請看第26/116頁）選擇Bracketing。
  - 顯示幕會出現包含三個項目的子選單：Frames、Aperture stops及Automatic。下面還有一條刻度尺。如果您同時啟動曝光修正功能，此功能的相關值會出現在刻度尺下方。
2. 在Frames項目下選擇是否使用包圍曝光或拍攝張數。
  - 刻度尺上被選取而有紅色標示的區間上方會出現白色的三角形。它們指出當前的曝光值。
3. 確認設定。
  - 間隔Aperture stops
4. 選擇想要的級數。
  - 有標示的區間以及三角形會隨著您所選取的間隔級數更換位置。

### 提示：

- 如果因為拍攝張數與級數組合之故，包圍曝光超出 $\pm 3EV$ 的範圍，刻度尺的劃分會從 $\pm 3EV$ 變為 $\pm 6EV$ 。有標示的區間以及三角形會跟著走。
- 請注意：您必須採用並確認這兩種設定，否則此功能不會啟動。
- 所設置的包圍曝光在從菜單中重新關閉之前，不會失效，而且不論相機在此期間是否關閉後又重新開啟。

5. 確認設定。
  - 自動Automatic
6. 選擇想要的設定。選擇ON表示在一次快門操作後自動進行後續拍攝，選擇OFF表示一次快門操作僅執行一次拍攝。
7. 確認設定。
  - 在輸出選單清單裡會將設定的包圍曝光，以XEV/X<sup>1</sup>的型式顯示。
8. 相機會經由一次或多次的快門啟動操作（請看第22頁）拍出您所設定的張數。

**提示：**

- 使用自動包圍曝光功能時，請遵守以下規則：  
相機自動為無曝光補償攝影所設定的感光度也會用在這一系列攝影的其他拍攝中；換句話說，該ISO值在這一系列攝影中不會更動。可能會導致超過Set maximum exposure time提供的最長快門時間。
- 隨著初始快門時間的不同，自動包圍曝光的工作範圍也受到限制。
- 不管如何一定會拍預定張數的相片，結果可能一次包圍曝光裡有好幾張以相同的曝光條件拍攝。
- 閃光燈作業模式也可使用自動包圍曝光功能，不論閃光燈的電量多低，都能完成包圍曝光，也就是不論是否開啟閃光燈，都能完成一系列曝光拍照。
- 此功能在其於Pictures子選單中再次關閉前一直保持作用，也就是在完成相關的關閉後，再次開啟動作。若未關掉，每次按下快門鈕就會再度拍攝出一連串包圍曝光的相片。

<sup>1</sup> 第一個「X」表示間隔級數，第二個表示拍攝張數

## 手動設定曝光

如果要完全用手動設定曝光的話，快門時間設定轉盤就必須轉到某格快門時間上，或停在兩格中間。

然後

1. 啟動測光表，而且
2. 旋轉快門時間設定轉盤及/或鏡頭的光圈設定環，依發亮的三角形LED所指示的方向，讓圓形LED單獨亮起。

除了指示快門時間轉盤及光圈設定環的正確選轉方向外，光量計的三顆LED也會以下列方式顯示曝光不足、過度或適當：

- ▶ 至少1光圈級數的曝光不足；必須向右轉
- ▶● 曝光不足 $1/2$ 光圈格數；必須向右轉
- 適度曝光
- ◀ 至少 $1/2$ 光圈級數的曝光過度；必須向左轉
- ◀ 至少1光圈級數的曝光過度；必須向左轉

### 提示：

曝光時間若大於2秒，按下快門後，觀景窗會顯示倒數剩下的曝光時間。

## B快門設定/ T功能

使用B快門設定時，只要按住快門鈕，快門就會一直維持在開啟狀態（最多60秒；視ISO的設定而定）。

另有T功能配合自拍功能供您選用：若是已經設定B快門，而且自拍器也藉由碰觸快門鈕而啟動（請看第68頁），快門就會在選定的預設時間之後自行打開，然後就會一直維持開啟狀態 – 不用繼續按著快門鈕不放，直到再碰觸快門鈕第二次為止，如此，即便在長時間攝影中亦可避免因操作快門鈕而可能產生的晃動。測光表在這兩種情形下都會維持在關閉狀態，不過快門釋放後，觀景窗的數字顯示會以秒為單位顯示曝光時間的流逝。

## 較長快門時間的固定設定

1. 按下對焦按鈕。
  - 顯示幕出現快門時間子選單。可用的快門時間（視ISO感光度而定）以白色標示，不可用的快門時間以灰色標示。
2. 使用快門時間設定轉盤或左/右十字鍵選擇想要的快門時間。
  - 放開對焦按鈕之後，子選單會繼續顯示約2秒鐘。
3. 請您按下快門。

**提示：**

- 長時間曝光下會有非常嚴重的畫面雜訊。
- 為了減少這種擾人的現象，徠卡M Monochrom會自動在每一次以較長快門（大約從 $1/30$ 秒起，視其他選單設定而異）拍攝之後，產生第二張「全黑相片」（在快門全關的情形下）。隨之相機會從原先拍攝的影像資料，以數學運算法「消掉」在此平行攝影中所測得的雜訊。  
進行長時間曝光時，請務必考量這種作業所衍生的雙倍「曝光」時間。在這段時間內，不可以讓相機關機。
- 快門時間長於2秒時，監控螢幕會顯示Noise reduction 12s<sup>1</sup>訊息作為提示。

**超出或低於測量範圍**

若測光表的測光區處於手動設定模式，而且低於非常低的光線密度，則觀景窗左邊的三角形LED（▶）會閃爍表示警告，同理亮度過高時右邊的LED（◀）會閃爍。在光圈先決模式中，快門時間會繼續顯示。低於或超過必要的快門時間，最長的60秒以及最短的 $1/4000$ 秒也會閃爍顯示。因為測光是使用工作光圈進行，所以這種情況也可能因鏡頭光圈縮小而產生。放開快門鈕後，即使當前狀況低於測量範圍，測光表還是會繼續維持約30秒的啟動狀態。若在這段時間內光線條件有所改善（例如改變拍攝主題構圖範圍或放大光圈），則LED顯示訊息會從閃爍變成持續發亮（表示測量作業就緒）。

<sup>1</sup>此時間值僅為範例

## 閃光燈模式

相機可在真正攝影之前，用觸發一次或多次瞬間測試閃光，之後，開始曝光時，就會觸發主閃光燈。

所有會影響曝光的因素（例如攝影濾鏡、光圈設定的變更）都會自動納入考慮。

## 可用的閃光燈

以下閃光燈可以用於本相機。相機允許 TTL 閃光測定功能，并根據裝備的不同允許本說明書中所述的許多不同功能。

- 系統閃光燈徠卡SF 26，既小巧又有和相機很搭調的設計，特別適合用在此相機上。以操作容易著稱。
- 徠卡系統閃光燈
- 具備系統3000的SCA (System-Camera-Adaption) 的技術條件、備有SCA-3502-M5'轉接頭、接受閃光導數的操控（請看第頁）的閃光燈。

亦可使用其他市售、具備標準閃光燈接腳以及正極中央接點的外接式閃光燈，透過中央接點(X接點)來觸發。我們建議您使用現代的晶閘管控制的電子式閃光燈。



## 裝上閃光燈

將閃光燈安裝在相機的靴座前，必須

- 先將不使用時保護靴座及接頭的護蓋往後拉出取下，及
- 關閉相機和閃光燈。

安裝閃光燈時要注意，將其腳座完全推進徠卡M的閃燈靴座裡面。而且(如果有的話)要用夾緊螺帽固定好，防止意外掉落。這一點對於有其他操控及訊號接點的閃光燈來說格外重要，因為它在靴座裡的位置變化，會中斷必要的接點連結，並且可能因此造成故障。

### 提示：

- 此步驟亦適用於使用SCA徠卡M的轉接頭組安裝閃光燈的情形（請看第96頁）。
- 未使用其他配件（例如燈光燈、外接式觀景窗或麥克風）時，務必蓋上靴座護蓋。護蓋可在有效期間限內保護接頭28，避免滲水。

## 閃光燈模式

此相機裝上前述系統相容的閃光燈後，不管您使用哪個曝光模式—光圈先決A或手動設定—都能選用全自動，亦即由相機操控的閃光模式。

在這全部三種曝光模式下，都有一種自動照亮模式。為了確定閃燈和現場光源保持平衡，在較高亮度下，閃光燈功能有時可能會減少多達 $1\frac{2}{3}$ EV。如果現場亮度加上最短的閃光燈同步時間（ $1/180$ 秒）會造成過度曝光，則在光圈先決模式下，不具HSS能力的閃光燈不會觸發。在這種情形下，快門時間會根據環境光線而調整，並且會顯示於觀景窗中。

此外，相機還可通過光圈先決 A 和手動設置激活更多具有設計意義的閃光技術，如將閃光觸發與曝光結束同步，而非通常與曝光開始同步以及 $1/180$ 秒較長快門時間作為同步時間的閃光。這些功能都可透過選單設定（進一步的資料詳見後面的相關章節）。

此外，相機會將設定的感光度傳給閃光燈。如此一來，只要閃光燈上有這類顯示訊息，而且可以用手動方式，把相機鏡頭上選擇的光圈設定在閃光燈上，閃光燈就可以自動配合調整其有效距離數據。感光度設定不會受到該閃光燈的影響，因為該設定值已從相機傳送。

**提示：**

- 攝影棚閃光燈設備的閃光時間通常都很長。因此在實際應用時可選擇 $1/180$ 秒以上的快門時間。
- 同樣情形亦適用於無線電操控的閃光燈快門按鈕（「激發的閃光」），因為無線電傳輸會造成延時。
- 下列章節只說明可用於此相機及系統輕巧型的閃光燈之設定和功能。
- 在相機上設定的曝光修正值（請看第54頁）只會影響現場光的測光！如果需要閃光拍照時同時對閃光曝光進行同步，必須分開設置。
- 如果要取得閃光作業（尤其是使用非徠卡M-P相機專用的閃光燈時），以及閃光燈不同作業模式的進一步資訊，請查閱閃光燈的使用說明書。

**由相機控制的設定，自動閃光燈作業**

啟動所用閃光燈、以及設定好導數控制（例如TTL或GNC=導數控制）作業模式之後，必須在此相機上：

1. 每當您要使用閃光燈攝影時，都要先輕輕壓下快門鈕啟動測光功能；換句話說，觀景窗內必須出現快門時間值或光量計。若過急地將快門鈕按到底，而沒成功完成上述動作，閃光燈可能不會觸發。
2. 快門時間設定轉盤設定在A、設定在閃燈同步時間（ $1/180$ 秒），或是設定在較長快門時間（包括B快門）。具有 HSS 功能的徠卡系統閃光燈也可將較短的快門時間設為同步時間。

**提示：**

如果測光模式在光圈先決模式下得到的作為同步時間的快門時間較短，則將會自動觸發 HSS 閃光，而非“普通”拍照閃光（請看第66頁）。

3. 設定您想要或合乎焦距需求的光圈。

**提示：**

若自動控制（請看第48頁的「閃光燈模式」）或手動控制的快門時間小於 $1/180$ 秒，則不會觸發閃光燈，除非該閃光燈具有HSS能力（請看第64頁）。

**以相容系統閃光燈攝影時，觀景窗內的閃光燈控制顯示訊息**

在觀景窗裡，有一顆閃電形狀的LED，用於回報及顯示不同的作業狀態。這個LED會和相關章節所說明的現場光線測光顯示訊息一起出現。

## 自動閃光燈模式

(閃光燈設定為導數操控或TTL)

- ⚡ 未出現，儘管閃光燈處於開機及待命狀態：  
相機上手動設定了比 $1/180$ 秒更短的快門時間，而且所連接的閃光燈不具HSS能力。在這類情況下，儘管閃光燈處於開機及待命狀態，相機也不會觸發它。
- ⚡ 在攝影前緩慢閃爍 (2Hz的頻率)：  
閃光燈還沒進入待命狀態。
- ⚡ 在攝影前發亮：  
閃光燈已在待命中

## 閃光燈設定成電腦控制(A)或手動模式(M)

- ⚡ 未出現，儘管閃光燈處於開機及待命狀態：  
相機上手動設定了比 $1/180$ 秒更短的快門時間，在這類情況下，儘管閃光燈處於開機及待命狀態，相機也不會觸發它。
- ⚡ 在攝影前緩慢閃爍 (2Hz的頻率)：  
閃光燈還沒進入待命狀態。
- ⚡ 在攝影前發亮：  
閃光燈已在待命中。

## 閃光燈曝光修正值

通過該功能可以在不受曝光影響的情況下通過現有的光線有針對性地減弱或加強閃光曝光，例如在夜晚室外拍照時增強人面部亮度的同時保持光線氛圍。

### 設定該功能

- 從攝影參數選單 / 主菜單，(請看第26/116頁) 選擇 **Flash Exposure Compensation**。
  - 監控螢幕會出現一刻度尺以及一個紅色的EV值，其上方有個白色三角形標示當前的設定。若那些數值都是0，這表示該功能處於關閉狀態。
- 設定您想要的值。
  - 在輸出選單清單裡會將設定的包圍曝光，以 **EV±X1** 的型式顯示。

該菜單功能只有當使用本身不具備該設置功能的、系統相容的閃光燈 (例如徠卡 SF 26) 時才可用。

### 提示：

- 閃光曝光補償改變了閃光燈的有效範圍。
- 已設置完畢的補償修正值無論拍攝多少張相片、甚至在關閉相機後仍然保持激活狀態，直到重置為± 0 (刻度尺中央)。

## 高速同步閃光模式 (HSS)

在相機裝上相應的徠卡系統閃光燈後，不管在任何快門時間、光圈先決及手動曝光設定等條件下，都能選用全自動、亦即由相機操控的高速同步閃光模式。如果選擇或計算所得的快門時間比同步時間短， $1/180$ 秒，相機就會自動啟動此模式。正確設定閃光燈時，這個切換動作不需要做其他攝影動作。

### 重要：

HSS閃燈的有效範圍比TTL燈的有效範圍小很多。

## 選擇同步時間/同步時間範圍

現場光線的再現效果深受快門時間以及光圈級數的影響。為閃光作業設定最短快門時間——同步時間——時，這種設定在很多狀況下會在未得到閃光燈適當補光的攝影主題部位引發不必要、或多或少曝光的不足現象。

此相機可讓您在閃光作業中搭配光圈先決功能時，依當前的拍攝主題條件，或是您對影像的偏好微調快門時間。在這方面，有五種設定供您選用：

## 設定該功能

1. 從主選單（請看第26/116頁）選擇**Auto Slow Sync**（第1頁，**CAMERA**區域），然後
2. 在所屬的子選單選擇 **$1/\text{focal length}$** <sup>1</sup>（自動的、受限於鏡頭條件的設定）或是**Manual setting**（如果您想自行選用一特定快門時間）。
3. 您可以在**Manual setting**子選單裡設定最短的可用快門時間，以定出可用快門時間的範圍。

### 提示：

- **$1/\text{focal length}$** 代表最長的快門時間，是根據拍攝時不會手震的簡易法則，例如用50mm鏡頭時為 $1/60$ 秒，但是，**Auto Slow Sync**選單有設定它的極限值： $1/125$ 秒，即使使用更長的焦距，也不得超過此值。
- **Manual setting**子選單的設定欄位會先出現目前設定的最長快門時間。
- 手動操控曝光時，所有快門時間，包括同步時間 $1/180$ 秒，也都可以選用。
- 若使用具有HSS功能的徠卡系統閃光燈而且設定較短的快門時間（即小於 $1/180$ 秒），閃光燈會自動切換為HSS模式。

<sup>1</sup> 只有在使用接座上有6位元辨識碼的徠卡M型鏡頭，並在選單中啟動鏡頭辨識功能時，才能使用。

## 選擇同步時間點

閃光燈攝影的曝光是由兩種光源達成：現場光線及閃光燈光線。只有或主要靠閃光燈照明的攝影主題部位，可藉由極短的瞬間光線拍得十分清晰（有正確對焦的前提下）。相對的，所有其他攝影主題部位——用現場光源照明就夠或自己會發光的部位——在整張相片的清晰度就會有差異。這些拍攝主題部位是會清晰或「模糊」重現（以及「模糊」的程度），取決於兩種獨立因素：

1. 快門時間的長度，亦即這些拍攝主題部位在感測器上的「作用」時間長度
  2. 這些拍攝主題部位（或是相機）在攝影過程中的移動速度
- 快門時間越長、以及運動越快，這兩個（互相重合的）局部畫面就越明顯不同。

閃光燈觸發動作的傳統時間點是在曝光開始時，也就是在第一道快門簾幕完全打開影像遮罩之後。這時有可能產生視覺上不合理的情形，例如在摩托車的相片上，摩托車的光線軌跡超越了摩托車本身。

此相機允許您選用這種傳統的閃光燈觸發時間點，或是選擇在曝光結尾處同步，亦即在第二道快門簾幕剛要開始再度關閉影像遮罩之前。這時，清晰的畫面會出現在運動結尾之處。這種閃光技術能賦予相片自然的動態感。

此功能可於以下情形使用

- 相機及閃光燈的所有設定
- 閃光燈直接或使用SCA轉接頭組安裝在相機的情形
- 光圈先決及手動快門時間選擇
- 自動及手動閃光燈模式

這兩種情形的顯示訊息都一樣。

## 設定該功能

1. 從主選單（請看第26/116頁）選擇Flash Sync.（第1頁，CAMERA區域），然後
2. 在附屬的子選單選擇想要的項目。

## 其他功能

### 拍攝影片

可使用此相機拍攝影片。可使用的功能如下：

#### 關閉解析度／拍攝影片

1. 從攝影參數選單（請看第26/116頁）選擇**Video Resolution**。
2. 在子選單裡選擇想要的設定。三種解析度可以和兩種不同的影像頻率組合，確保在電視系統上重現：25張/秒適用於PAL，24張/秒適用於NTSC。若要確保即使在意外啟動影片快門按鈕時也不會拍攝影片，請選擇**Video OFF**。

#### ISO感光度

37-38頁說明的所有設定（適用以下有關快門時間的限制說明）

#### 提示：

特別是在以高ISO感光值拍攝包含非常亮的點狀光源的陰暗被攝目標時，有可能在整個畫面裡看得到垂直和水平條紋。

#### 焦距設定

第46-49頁上所有所述的模式不包括截屏放大以及畫面上攝影主題清晰度標示。

#### 測光方法

所有在第50 頁說明的選項

#### 測光作業模式

- 光圈先決（請看第52頁）
- $1/30$ - $1/4000$ 秒快門時間手動操控較長的快門時間設定，將如同 $1/30$ 秒處理。

#### 銳利、對比度

所有在第39 頁說明的選項

### 提示：

為了確保相同的曝光，應進行手動設定快門時間。主題變動（如搖射）可能造成干擾性的亮度變動。

### 開始/結束攝影

按一下影片快門按鈕開始拍攝，再按一次結束拍攝。

- 在實時取景模式下，影片拍攝過程會以閃爍的紅點和拍攝計時訊息顯示在顯示幕上（請看第44/110頁）。在觀景窗則以兩個數位顯示點交替閃爍的方式呈現。採用該相機的16:9格式拍攝影片在畫面的上下方顯示幕內會出現黑條。

拍攝影片期間可進行單張拍攝。按下快門進行單張拍攝時，會中斷影片的拍攝。單張拍攝適用當時的相機設定。

### 錄音

可使用內建的麥克風進行單音錄音。必須使用隨產品提供的外接式麥克風，才能進行立體聲錄音（請看第97頁）。

### 設定該功能

- 從主選單（請看第26/116頁）選擇**Audio**（第4頁，**SETUP**區域）。
  - 所屬的子選單提供**Audio Adjustment**及**Wind Elimination**項目。

有兩個選項可用來製造音效，還可以手動設定調整音量或關閉錄音。

- 從音效設定子選單選擇**Standard**、**Concert**或**Manual**。
  - 若選擇**Manual**，麥克風符號 (Q) 及目前設定的音量級 旁邊會出現一個長條圖，提供以下資訊
    - 目前音量讀數
    - 峰值讀數<sup>1</sup> (D)
    - 全尺寸標示

<sup>1</sup>峰值讀數指出最後5秒的最大值。

## 手動設定

3. 使用設定轉盤（往左 = 下/往右 = 上），或使用上/下十字鍵設定音量級。也可在拍攝過程中完成此設定，但必須先按下INFO按鈕。音量級0代表無錄音。為了避免接管控制，所選擇的音量級應確保峰值讀數不會或非常不可能超過全尺寸標示，或僅些微超過。為了一目了解，低於此標示的讀數應以白色標示，高於此標示時應以紅色標示。

### 提示：

在單音錄音時，長條圖兩側（= 通道）保持平行，立體聲錄音為通道分離。

即使為立體聲錄音，音量調整亦非通道分離。

為了避免風造成的錄音雜訊而提供一個兩段式阻尼。

2. 從Wind Elimination子選單選擇OFF、Medium或High。只有在完全不存在風造成雜訊的情況時，才能選擇OFF以確保最佳錄音。

## 以自拍器攝影

利用自拍器時，您可以選擇延遲2或12秒拍攝相片。第一個選項特別適用於避免在按快門時晃動而產生不清晰的畫面。第二個選項適用於拍團體照而您自己也想出現在相片時，建議您將相機固定在三腳架上。

### 設定及使用該功能

1. 將主開關旋轉到.
2. 從主選單（請看第26/116頁）選擇Self-timer（第1頁，CAMERA區域），然後
3. 在附屬子選單選擇想要的預備時間。
4. 若要開始前置時間，請按下快門按鈕至第二個壓點，請參閱第23頁）。
  - 發光二極體可呈現前置時間的進行過程，12秒前置時間中的前10秒先閃爍，然後變成持續發亮，在顯示幕裡也會同時倒數計時。

自拍器啟動的12秒前置時間流逝前，您可隨時按下SET或MENU按鈕中斷此作業；當前的設定會留著，而且重新輕觸其中一個快門鈕即可重新開始。

### 重要：

自拍作業的曝光的設定並不是在按下快門鈕時進行，而是在拍攝之前的瞬間。



## 標示影像檔案與著作權保護

此相機讓您可利用文字及其他標記，標示您的影像檔案。為此，您可以在每次拍攝時，於2個欄位中提供最多17個字元的資訊。

1. 從主選單（請看第26/116頁）選擇 **Copyright Information**（第4頁，**SETUP**區域）。
  - 顯示幕上出現一個含有三個項目的子選單：**Copyright Information**、**Information**及**Artist**。開始時只啟用 **Copyright Information**列。
2. 啟動 **Copyright Information**功能，並確認啟動。
  - 接著啟用資訊列，第一個位置標示為可供編輯。
3. 使用設定轉盤選擇想要的列；按下十字鍵的相應方向按鈕選擇其他區域。可在**Artist**列按下十字鍵的相應方向按鈕或使用**INFO**按鈕或**SET**按鈕完成選擇。您可選擇不同的標點符號、**0**到**9**的數字、大/小寫字母及空格符號；這些符號依此順序組成一個無限迴圈。
4. 按一下**SET**或**INFO**按鈕，確認您的設定。

## 用GPS功能記錄攝影地點





必須先安裝多功能手把（隨產品提供的配件，請看第96頁），才能使用這些選單項目。

全球定位系統（GPS）可定出其訊號接收器在世界任一角落的方位。多功能手把配備相應的接收器。手把安裝到相機後，相機將可接收相關訊號並更新位置資料。它能將經度、緯度及海拔等資料寫入EXIF資料裡。

### 提示：

相應的相機選單功能必須在安裝了多能手把後才能使用。

## 設定該功能

1. 從主選單選擇**GPS**（第4頁，**SETUP**區域），然後
2. 於此處選擇**ON**或**OFF**。
  - 顯示幕上的「衛星」符號  顯示當時狀態（僅在攝影資料顯示區）：
    -  = 上次定位是1分鐘內
    -  = 上次定位是5分鐘內
    -  = 上次定位已超過5分鐘，或是沒有位置資料

### 功能須知：

- GPS天線位於上方多功能M型手把的手把部位。
- GPS定位的先決條件是盡可能讓天線「無阻礙地」朝向天空。因此，應盡量讓相機上的GPS天線垂直向上指。
- 定位可能需要幾分鐘的時間。特別是在相機關閉和重新開啟時間間隔較長，以致衛星位置明顯改變需要重新鎖定其位置時，就需要數分鐘的定位時間。
- 請注意別讓手或其他（尤其是金屬類）物品遮到GPS天線。
- 在下列地方或情況，可能會無法順利接收GPS衛星的訊號。這時可能會根本無法定位或得到錯誤的定位結果。
  - 密閉空間中
  - 地底下
  - 樹下
  - 行進中的車子裡
  - 高樓附近或峽谷內
  - 高壓電纜附近
  - 隧道內
  - 1.5 GHz行動電話附近
  - 使用裝在靴座上的配件，例如閃光裝置

### 安全應用須知：

GPS系統所產生的電磁場可能會干擾儀器與測量器材。因此，當您搭乘的飛機起飛或降落前，或在醫院或其他有無線通訊限制的場所時，請記得關閉GPS功能。

### 重要（法令規定的使用限制）：

- 在某些國家或地區，GPS以及相關技術的使用，可能有所限制。因此，出國旅遊前，請務必向當地的大使館或旅行社徵詢這方面的資訊。
- 中國及古巴法律規定，不可在其境內及其邊界附近（例外：香港及澳門）使用GPS。違反規定會遭受其法令制裁！因此，GPS功能會自動在這些地區關閉。

## 使用者/使用者特定風格

此相機允許您將任何選單設定組合儲存起來，以便日後遇到同樣的狀況 / 拍攝主題時，能迅速開啟所有相關功能。本機提供四個儲存位置給您儲存這類設定組合，此外還有一個可隨時開啟、不能變更的出廠設定。您可以變更已儲存的使用者設定檔名稱。

您可以將此相機設定的使用者設定檔轉存到記憶卡上，以便在其他相機上應用。同樣地，您可以將存放在記憶卡上的使用者設定檔傳送到此相機。

## 儲存設定/建立使用者設定檔

1. 在選單裡設定您想用的功能。
2. 從攝影參數選單（請看第26/116頁）選擇 **User Profile**。
3. 在子選單選擇 **Save as user profile**，並且
4. 在相關子選單選擇想要的儲存位置。

## 選取使用者設定檔

1. 從攝影參數選單（請看第 26/116頁）選擇 **User Profile**。
  - 儲存使用者設定檔後，設定檔名稱會呈現灰色，沒有用到的儲存位置則會呈現綠色。
2. 從子選單選取想用的使用者設定檔：一個已儲存的設定檔，還是 **Default user profile**。

### 提示：

您若變更剛才所用之使用者設定檔中的某項設定，初始選單清單會出現---符號，而非先前所用的使用者設定檔名稱。

## 更改使用者設定檔名稱

1. 從攝影參數選單（請看第26/116頁）選擇 **User Profile**。
2. 從子選單選擇 **Manage profiles**，然後
3. 在所屬的子選單裡選擇 **Rename profiles**。
  - 特定風格名稱及編號就會出現，編號會標示成已經可以進行編輯。
4. 轉動設定轉盤或是使用上/下十字鍵，選取您想更改名稱的使用者設定檔。
5. 按一下 **SET** 或 **INFO** 按鈕，或按下十字鍵的向右按鈕確認您的設定。
  - 下一個位置標示為可供設定。
6. 轉動設定轉盤或按上/下十字鍵變更名稱的數字或字母。按以下按鈕選擇其他區域
  - **INFO** 按鈕
  - 或 **SET** 按鈕，
  - 或按左/右十字鍵。您可選用 **▲** 至 **▼** 的大寫字母、**0** 至 **9** 的數字以及空格符號 **■**；些符號依此順序組成一無限迴圈。
7. 按 **SET** 或 **INFO** 按鈕，確認您的設定（最後一個位置必須保持開啟）。

## 將使用者設定檔儲存在記憶卡上/從記憶卡讀取

1. 從攝影參數選單（請看第26/116頁）選擇 **User Profile**。
2. 從子選單選擇 **Manage profiles**，然後
3. 從相關子選單選擇 **Import profiles from card** 或 **Export profiles to card**。
  - 顯示幕裡會出現對應的問題。
4. 按一下 **SET** 或 **INFO** 按鈕，或按下十字鍵的向右按鈕確認您的設定，表示您確實想要匯入或匯出設定檔。

### 提示：

輸出時，基本上會將四個使用者設定檔儲存位置全都傳送到記憶卡上，即使某個儲存位置上根本沒有使用者設定檔也一樣。因此，輸入使用者設定檔時，所有相機裡現存的使用者設定檔都會被覆寫，亦即刪除。

## 回復所有個別設定

您可利用此功能，將所有先前在主選單及攝影參數選單執行的個人設定，回復成出廠基本設定。

### 設定該功能

1. 從主選單（請看第26/116頁）選擇 **Reset**（第5頁，**SETUP**區域），然後
2. 在附屬子選單選擇 **No** 或 **Yes**。

### 提示：

這種回復動作也對可能用使用者設定檔確認及儲存的個人設定檔有效。

## 播放模式

如要在相機的顯示幕上播放相片，有兩種模式供您選用：

- **PLAY**不限時播放

或是

- **Auto Review**緊接於攝影後的短暫播放

### 不限時播放 - PLAY

按一下**PLAY**按鈕，切換到播放模式。

- 顯示幕裡會先出現拍攝的相片，還有對應的顯示訊息(請看第113頁)。但是如果插入的記憶卡裡沒有任何相片檔案的話，則切換到播放模式之後就會出現對應的訊息：**Caution: No image to display** (無可顯示的相片)。

### 提示：

- 按壓**PLAY**按鈕，依先前設定的功能而定，會有多種不同的結果：

初始狀況	按PLAY鈕後
a. 全畫面播放相片	攝影模式
b. 播放多張縮圖中的局部放大圖 (請看第85頁)	全畫面播放該張相片
c. 啟動選單操控功能 (請看第26頁) 或啟動 <b>DELETE</b> 或保護功能 (請看第82/88頁)	全畫面播放最後顯示的相片

- 用此相機只能播放由這類相機所拍攝的相片資料。

## 自動播放最後一張相片

**Auto Review**模式中，相機每拍完一張相片就會立即展示。如此您可迅速且簡單的預覽檢查該相片是否成功拍攝或應重拍。此功能允許您設定相片顯示時間長度。

### 設定該功能

1. 從主選單（請看26/116頁）選擇**Auto Review**（第4頁，**SETUP**區域），
2. 在附屬的子選單裡選擇想要的選項，即時間長度：（**OFF**, **1 second**, **3 seconds**, **5 seconds**, **Continuous**, **Shutter release pressed**）。

**Auto Review**模式隨時切換到正常模式，也就是不限時的**PLAY**播放模式。

### 提示：

若使用連續拍攝功能(請看第24頁)，在兩種播放作業模式之下都會先顯示該系列的最後一張相片或者是該系列儲存在記憶卡的最後一張相片 - 除非該系列拍攝的所有相片都從相機內建記憶體轉存到記憶卡了。如欲選取該次連續攝影的別張相片，或欲瞭解播放時的其他可能性，請參閱下列章節之說明。

## 一般播放

為避免干擾您檢視相片，在一般播放模式，除了影像外，只會出現標題列的資訊。

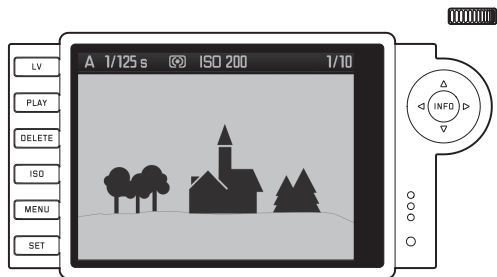

如果顯示局部畫面，將會出現頂列提供相應的顯示訊息。

## 播放影片

選擇拍攝影片後，即出現<sup>1</sup>作為提示。





若要播放影片，可使用**INFO**按鈕開啟下一個含有相關操控符號的選項。

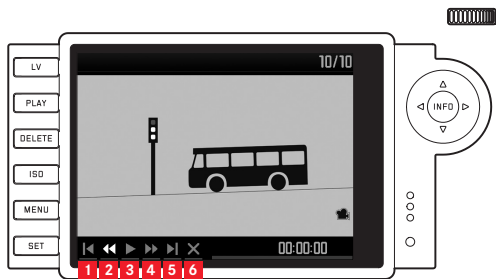

- 1 返回開頭處
- 2 快速倒轉
- 3 播放/暫停
- 4 快速前進
- 5 前進至最後
- 6 離開選項

使用左/右十字鍵或設定轉盤選擇想要的功能。按下**SET**按鈕啟動所選的功能，或按住該按鈕執行快速前進/倒轉。開啟時速度較慢，但按住的時間越久，速度變得越快。

- 啟動的功能符號以白色和紅色底線標示。

#### 提示：

由此可知，基於安全理由（請看第84頁）不可開啟選單。請使用**INFO**按鈕切換至其他視圖。

除了正常播放外，另外還有3個（單張拍攝）或2個（拍攝影片）內含不同資訊的選項可供選擇。所有4或3種模式組成一無限迴圈，（多次）按壓**INFO**就能開啟。

## 顯示色階分布圖

按一下（從一般播放模式開始算起）**INFO**按鈕，顯示色階分布圖。色階分布圖會出現在相片影像的下半部。

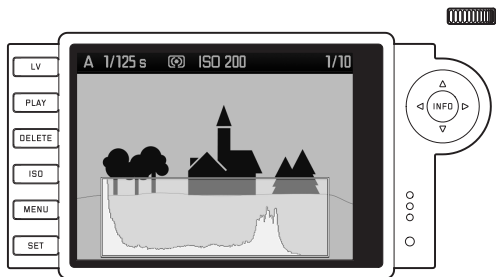

## 提示：

- 播放相片的完整影像或部分影像時，都可以開啟色階分布圖；同時播放四張、九張或三十六張縮圖時（請參閱第81頁），則不行。
- 色階分布圖的內容都是針對當前顯示在螢幕上的相片影像（請參閱第114頁）。

## 顯示削波部位

您可以在選單設定該顯示功能的削波閾值以及亮區或暗區的範圍值。

按兩下（從一般播放模式開始算起）**INFO**按鈕，顯示沒有影像內容的部位。

- 太亮的部位閃紅光；太暗則會閃藍光。此外，右下方會出現削波符號 (L)

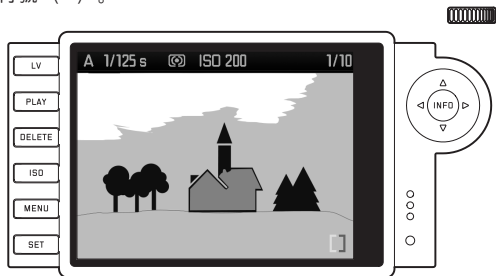

## 設定該功能

- 從主選單（請看第26/116頁）選擇 **Clipping**（第3頁，**SETUP**區域），然後
- 在子選單設定下閾值與上閾值。
  - 刻度尺會顯示削波部位在整體曝光範圍中的比例。

### 提示：

- 播放相片的完整影像或部分影像時，都可開啟削波部位顯示功能；同時播放4張、9張或36張縮圖時，則不行（請看第81頁）。
- 削波部位顯示內容都是針對當前顯示在螢幕上的相片影像（請參閱第81頁）。

## 顯示額外資訊

按三下（從一般播放模式開始算起）**INFO**按鈕，顯示額外拍攝資料及一張縮圖。



### 提示：

這個模式只會顯示完整的影像，不管之前是否只顯示局部影像。

## 觀賞其他相片/記憶體內「翻頁」

您可以用左/右十字鍵叫出其他儲存的相片。按左十字鍵叫出上一張相片，按右十字鍵叫出下一張相片。第一張或最後一張相片之後，組成一無限迴圈的相片又會從頭排起，讓您能從任一方向逐一開啟所有相片。

- 監控螢幕會顯示當前影像的相片及檔案編號。

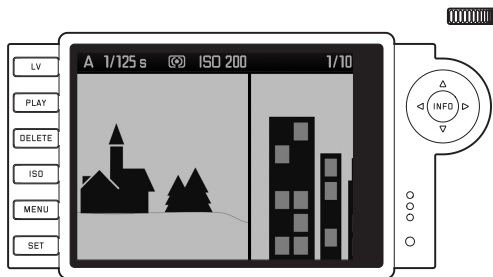

## 放大/選擇局部畫面/同時觀賞多張縮小相片

此相機允許您將單張相片變成放大的局部畫面，而且可自由選擇局部畫面，以便更確切地審視影像。您也可以，相反的，為了概略檢視相片或快速尋找某張相片，讓監控螢幕同時顯示多至36張相片。

### 提示：

- 拍攝低解析度相片（如1.7MP）時，將無法使用所有放大級數。
- 只要相片放大顯示，左/右十字鍵就無法用來呼叫其他相片，而是變成用來在相片裡「操控方向」（例外：請看下一個提示）。

將設定轉盤向右旋轉，可將中央的畫面局部放大。放大到最後一級時，螢幕的一像素相當於相片的一像素。

您可以用四個十字鍵在放大的影像裡，另外任意選擇局部畫面的擺放位置，為此請依您想要的畫面推移方向（多次）按壓相應的十字鍵。

- 顯示幕右上角框裡的方塊，不但代表當時放大的區域，同時也代表所顯示局部畫面的位置。

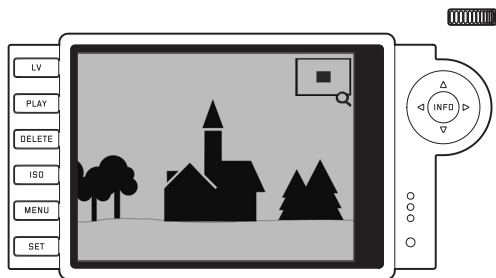
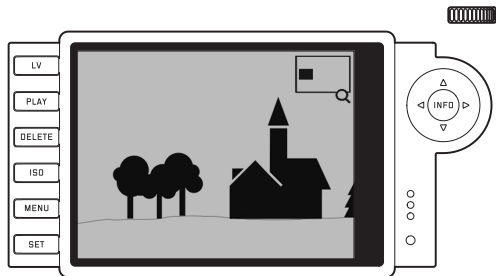

**提示：**

您也可以從放大的影像直接切換到別張相片，而且會以相同的放大率顯示。方法是再按左/右十字鍵，但要同時按住**PLAY**按鈕。

設定轉盤向左轉（從一般尺寸開始），就能同時檢視4張相片再繼續轉下去則可檢視9或36張相片。

- 顯示幕裡可顯示最多36張縮圖，先前以正常大小觀賞的相片，會以紅色外框標示出來。

您可以用四個十字鍵自由瀏覽縮圖，選取的相片就會對應標示。可以將設轉盤向右轉動，或按**INFO**或**PLAY**按鈕，恢復以正常大小觀賞該相片。

**提示：**

播放36張相片時，若繼續向左轉動設定轉盤，紅框會圍住整組相片；這時，您就可以一組一組地快速「翻頁」。

**刪除相片**

每當監控螢幕顯示相片時，您都可刪除該張相片。例如相片已儲存在別的媒體、您不再需要這張相片或是得在記憶卡上騰出更多儲存空間時，這個功能就很實用。您可以一張一張地或同時多張地刪除相片。

**提示：**

- 刪除功能只能在播放模式中使用，但不限播放尺寸以及同時播放的張數（不過，在36格播放模式中，紅框若圍住整組，就無法啟動刪除功能）。
- 受保護的相片必須先取消防止刪除功能後才能予以刪除（請參閱下一章節）。

**步驟**

- 按下**DELETE**按鈕。
  - 顯示幕畫面出現對應的子選單。

**提示：**

可隨時按**PLAY**或 **DELETE**按鈕中斷刪除。

2. 首先您要決定是否一張一張刪除**Delete single**，或同時刪除所有相片**Delete all**。
3. 按下**SET**按鈕，確認您的選擇。您可以左/右十字鍵叫出其他相片。

**提示：**

- 若顯示的相片有刪除保護(請看第84頁)，則無法在子選單裡選擇功能選項**Single**。
- 要刪除所有相片時，為了防止意外刪除，您必須再確認一次，確定您真的想要刪除記憶卡上所有的相片。

**刪除後的顯示訊息**

刪除後，會出現下一張相片。如果記憶卡上沒有相片，就會出現下列訊息：**Attention No image to display**。

**刪除記憶卡上全部相片**

刪除後，會出現下列訊息：**Attention No image to display**。若有一張或一張以上相片有防止刪除的保護，該相片或是這些相片裡的第一張就會顯現。

**提示：**

刪除相片會在相片計數器裡將後面的相片全部跟在前面相片後重新編號。例如刪除第3號相片，原來的第4號相片就會變成第3號，原來的第5號相片變成第4號，以此類推。不過這點不適用於記憶卡上的檔案編號。

## 保護相片 / 取消防止刪除功能

記錄在記憶卡上的相片，可被施加保護功能，防止意外刪除。這種防刪除保護亦可隨時取消。

### 提示：

- 無論是施加防刪除保護功能還是解除防刪除保護功能，都只能在播放模式中進行，但不限播放尺寸以及同時播放的張數（不過，在36格播放模式中，紅框若圍住整組，就無法啟動這些功能，請參閱第81頁）。
- 對受保護的相片進行刪除動作時，相機的各種反應詳見於前面的章節。
- 若確定要刪除這類相片，請先依下列說明取消其保護功能。
- 防刪除保護功能只有在相機內才有效。
- 將記憶卡格式化時，受保護的相片也會被刪除（請參閱下一章節）。
- 在SD/SDHC/SDXC記憶卡上您可以防止意外刪除，方法是將卡上的防寫開關推到標示著LOCK的位置（請看第17頁）。

### 步驟

1. 按下SET按鈕。
  - 顯示幕畫面出現對應的子選單。

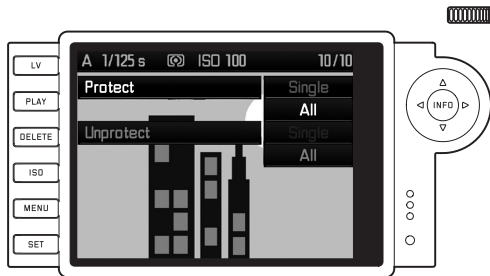

### 提示：

設定過程可以隨時中斷

- 按下**PLAY**按鈕 - 以便回到正常播放模式，
- 或是輕觸其中一個快門按鈕 - 以便跳到攝影模式。

### 2. 請選擇，

- 是要一張一張**Protect single**，還是
- 同時對所有相片施加保護功能**Protect all**，或是
- 要解除單張相片的防刪除保護功能**Clear protection Single**，或是
- 解除所有相片的防刪除保護功能**Clear protection All**。



**提示：**

欲進行下列動作時，相關功能在選單上的字體會從亮色變成暗色，以示無法使用：

- 對一張已經受保護的相片施加保護功能。
- 對一張未受保護的相片解除防刪除保護。

3. 按下**SET**按鈕，確認您的選擇。您可以用左/右十字鍵叫出其他相片。

**保護後的顯示／取消刪除保護**

離開相關過程後會再度出現原來的顯示幕畫面，在受保護的相片上會出現一個對應的顯示訊息 (🔒)。

**提示：**

一張已受保護的相片被開啟時，顯示訊息 (🔒) 也會出現。

## 其他功能

### 資料夾管理

記憶卡上的相片資料儲存在資料夾裡，會自動產生。資料夾名稱基本上由八個字元組成——三個數字加五個字母，出廠時第一個資料夾名稱為「100LEICA」，第二個稱為「101LEICA」，依此類推。基本上，資料夾編號會自動使用下一個可用的數字；最多可建立999個資料夾。如果可用數字用完了，監控螢幕會出現一則相關警告訊息。

資料夾內的相片基本上會冠上連續數字編號（直到9999），除非選用的記憶卡上已有相片編號比相機最後一次發派的編號數字大。在這種情況下，該相片在記憶卡上的編號作業會從該數字接續下去。當前資料夾若含有編號9999的相片，相機會自動建立一個新的資料夾，並再次從0001這個號碼開始為相片編號命名。在達到資料夾編號999及相片編號9999時，顯示幕會出現相關警示訊息，編號功能必須重置（請參閱下方說明）。此相機允許您自行建立新的資料夾、自行訂定資料夾名稱、更改檔案名稱。

### 變更資料夾名稱

1. 從主選單（請看第26/116頁）選擇 **Image numbering**（第4頁，**SETUP**區域），然後
2. 從其子選單選取 **New folder**。
  - 資料夾名稱出現（最初都是 **XXXLEICA**）。第4個位置上的字元已經標示成可供編輯。您可以更改第四至第八位的符號。

#### 提示：

若使用未經此相機格式化的記憶卡（請看第88頁），相機會自動建立一個新資料夾。

3. 轉動設定轉盤或按上/下十字鍵變更數字或字母。按以下按鈕選擇其他區域
  - **INFO**按鈕
  - 或**SET**按鈕，
  - 或按左/右十字鍵。您可選用 **▲**至 **▼** 的大寫字母、**0**至 **9** 的數字以及底線符號 **\_** 這些符號依此順序組成一無限迴圈。

**X**字元代表該空位。

- 按**SET**或**INFO**按鈕，確認您的設定（第8個位置必須保持開啟）。
  - 一個提出**Reset image numbering?**問題的子選單隨即出現。
- 選擇**Yes**或**No**。

## 變更影像檔案名稱

- 從主選單（請看第26/116頁）選擇**image numbering**（第4頁，**SETUP**區域），然後
- 在所屬的子選單裡選擇**Change file name**。
  - 出現影像檔案名稱。第1個位置上的字元已經標示成可供編輯。  
您可以更改第一至第四位的符號。
- 轉動設定轉盤或按上/下十字鍵變更數字或字母。按以下按鈕選擇其他區域
  - **INFO**按鈕
  - 或**SET**按鈕，
  - 或按左/右十字鍵。您可選用**A**至**Z**的大寫字母、**0**至**9**的數字以及底線符號**\_**這些符號依此順序組成一無限迴圈。
- 按**SET**或**INFO**按鈕，確認您的設定（第4個位置必須保持開啟）。
  - 第2點所描述的設定選單再度出現。

## 重置影像檔案名稱

1. 從主選單（請看第26/116頁）選擇 **Image numbering**（第4頁，**SETUP**區域），然後
2. 在附屬的子選單裡選擇 **Reset**。
  - 一個提出 **Reset image** 問題的子選單隨即出現。
3. 選擇 **Yes** 或 **No**。
  - 按下 **INFO** 或 **SET** 按鈕確認選擇後，第二點所描述的設定選單會再度出現。

## 將記憶卡格式化

正常情形下並沒有必要將已經插入的記憶卡格式化。但若首次插入一個尚未格式化的記憶卡，就需要執行格式化功能。

### 提示：

儘管如此，仍應養成習慣將您的相片儘快複製到安全的儲存裝置，例如您電腦的硬碟。需將相機連同記憶卡一起送修時，尤應採取此安全措施。

### 步驟

1. 從主選單（請看第26/116頁）選擇 **Format SD card**（第5頁，**SETUP**區域），然後
2. 在所屬的子選單裡選擇 **Format SD card?**
3. 按下 **SET** 或 **INFO** 按鈕，對記憶卡執行格式化。

### 提示：

- 如果記憶卡是在別的裝置裡，例如電腦裡格式化的話，則應在徠卡M裡重新格式化。
- 如果該記憶卡無法格式化，請洽詢您的經銷商或徠卡的資訊服務部（地址詳見第124頁）。

## 將資料傳送到電腦

記憶卡上的相片資料可以通過兩種方式轉存在一臺電腦上。

- 通過多功能M型把手（請看第96頁）該配件有一個USB 2.0 接口，用於讀取安裝在相機內的記憶卡。
- 通過用於SD/SDHC/SDXC卡的讀卡器相機與以下操作系統相容：
  - Microsoft®: Windows® XP / Vista® / 7® / 8®
  - Apple® Mac® OS X (10.6)

### 提示：

- 有關手把功能、操作及其他詳細資訊，請參閱相關說明書。
- 在一台電腦上透過USB集線器（「Hub」）或延長線連接兩台或兩台以上的裝置時，可能會有不順的現象。

## USB連線

通過USB線傳輸數據可以採用兩種不同的標準。主要考慮到有些操作系統要求使用符合PTP協定的連結以傳輸影像資料。

此外，您也可將相機當成一部外接式磁碟機（「大量儲存裝置」）使用。

### 設定該功能

1. 從選單（請看第26/116頁）選擇**USB mode**（第5頁，**SETUP**區域），然後
2. 在所屬的子選單裡選擇**PTP**或**Mass Storage**。

### 採用PTP協定連接及傳輸資料

若相機設定為**PTP**，請依以下說明操作：

3. 請用隨手把提供的多功能手把相應的接頭和電腦的接頭。

### 使用Windows® XP

- 連結成功後，桌上型電腦上會出現提示，告知其辨識到相機這個新的硬體（只有在第一次連結時！）。
4. 連點兩下提示。
    - 隨之會出現一個資料傳輸精靈的「M Digital Camera」下拉式選單。
  5. 請點選「OK」，隨之遵照輔助精靈的指示，以便從該處將照片複製到您選擇的資料夾。

### 使用Windows® Vista® / 7® / 8®

- 成功連接後，工作列上方會出現一個關於安裝新裝置驅動程式的提示訊息。相機螢幕上同時出現USB connection訊息。安裝成功的確認訊息會出現在下一個提示視窗。這時會打開「自動播放」選單，連同各種裝置選項。
5. 您可如常透過Windows的精靈執行「輸入相片」或「開啟裝置檢視資料」。

### 使用 Mac® OS X (10.5 或以上)

- 相機與電腦連結成功後，相機螢幕上會出現USB Connection訊息。
4. 在電腦上打開「Finder」。
  5. 在視窗左邊區域的「地點」類別點選「程式」。
  6. 在視窗右邊區域點選「Digital Images」程式。
    - 程式啟動，並且在程式標題列出現「M數位相機」的名稱，
  7. 現在您可使用「Load」鍵將相片傳送到電腦上。

## 將相機當作外接磁碟機（大量儲存裝置）進行連結及資料傳輸

**先決條件：**相機/多功能M型手把組合透過USB線和電腦連線。

- 使用Windows®作業系統：

如果徠卡M透過USB線和電腦連線，則會被作業系統辨識為外接式磁碟機，並且會被指定一個磁碟機代表字母。

- 使用Mac®作業系統：

如果徠卡M透過USB線和電腦連線，則插入的記憶卡就會當成是儲存媒體出現在桌面上。可使用Finder功能直接存取檔案。

**提示：**

- 在100LEICA、101LEICA等資料夾裡最多可以儲存9999張相片。
- 此功能處於啟動狀態時，所有其他相機功能都無法使用。

**重要：**

- 只可使用隨手把提供的USB傳輸線。
- 將徠卡M上的資料傳輸到電腦時，請切勿拔除USB訊號線造成兩者連結中斷，否則電腦及/或徠卡M可能會「當機」，甚至可能會讓記憶卡遭受無法修復的損害。
- 將徠卡M上的資料傳輸到電腦時，請切勿將相機關機或發生因電池電力不足而關機的現象，否則電腦可能會因此當機。所以建議只有在電池容量足夠或使用多功能M型手把電源的情況下再進行數據傳輸。
- 如果在過程期間電池容量接近結束，請退出并關閉相機。重複該過程，以便通過充好電的電池以及連接的電源傳輸尚未完成的數據。

## ADOBE® PHOTOSHOP® LIGHTROOM®

在徠卡相機公司網站為您的相機註冊後，就可免費下載、使用 Adobe® Photoshop® Lightroom®。有關其他詳細資訊，請參閱以下網頁上的「顧客服務區」：[www.members.leica-camera.com](http://www.members.leica-camera.com)，或者查詢相機包裝內的註冊卡。

## LEICA IMAGE SHUTTLE

獨家供應的LEICA Image Shuttle軟體可以讓人從電腦遙控相機，同時可以直接將相片資料儲存到電腦的硬碟上當成「遠端攝影」使用。此軟體能操控相機的所有重要功能，是一項能在攝影棚和「任何現場(室內室外任何場所)-」提供完美支援的便利工具。在徠卡相機公司網站為您的相機註冊後，就可免費下載、使用 LEICA Image Shuttle。有關其他詳細資訊，請參閱以下網頁上的「顧客服務區」：[www.members.leica-camera.com](http://www.members.leica-camera.com)，或者查詢相機包裝內的註冊卡。

### 提示：

必須安裝多功能M型手把（請看第96頁）才能使用此功能。

## 使用DNG原始資料

若選擇DNG（數位負片）格式，需使用相關軟體程式才能以最高品質轉換儲存的原始資料，例如原始資料轉換軟體Adobe® Photoshop® Lightroom®。該軟體有能改善品質的演算法，能將雜訊降到特別低的程度並實現令人驚奇的影像解析度。進行影像處理時，您可以事後調整例如減少雜訊、階調、銳利度之類的參數，進而達到最高水準的影像品質。



## 安裝韌體更新

徠卡致力於進一步開發、改善自己的產品。由於相機中有許多功能完全由軟體控制，因此某些改良與功能上的擴充，可於出廠後安裝於相機之中。

因此，徠卡會不定期提供韌體更新。

如果要瞭解說明書裡所列的規格是否會因此有所變更或補充，請瀏覽我們的網頁：

若要得知您的相機是否已安裝了最新的韌體，請查詢選單項目

**Firmware** (第5頁, **SETUP**區域)

您可從我們公司網站的首頁下載新的韌體，安裝到您的相機上。

1. 對相機內的記憶卡進行格式化。
2. 將相機關機，然後將記憶卡插入內建或外接到的電腦的SD/SDHC/SDXC讀卡機。
3. 從相機網頁中名為「UPDATES」的連結點，下載軟體檔案。
4. 將檔案 m-X\_xxx.upd儲存在記憶卡資料夾結構的最上層。X\_xxx表版本編號。
5. 將記憶卡自讀卡機中取出後插入相機內，並將底蓋蓋上後，開啟相機。

6. 按住**INFO**按鈕，開啟相機。

更新作業隨之啟動。可能需要多達15分鐘的時間。

### 提示：

- 充電電池的電力不足時，會出現**Battery low**警示訊息。請先對充電電池充電，然後再重複上述步驟。
- 請注意關於重新使用相機的所有提示。

## 其他

### 系統配件

#### 交換式鏡頭

徠卡M型系統提供了快速且低調攝影所需的最佳基本配備。此系列的鏡頭涵蓋了16至135mm的焦距範圍以及高達1:0.95的光傳量。

#### R型轉接頭M

不論焦距、固定焦距及變焦、最近對焦距離、使用何種控制凸輪（SL「斜面」/R「梯形」），以及是否有ROM接點列，徠卡R型轉接頭M都可讓您在徠卡M Monochrom型相機上，使用幾乎所有徠卡R型鏡頭。

若可能的話，應將此鏡頭搭配徠卡R系列延伸器及接合配件（如徠卡Macro轉接頭R、徠卡R型中介環及波紋管相機調整裝置R BR2）一起使用。

此相機藉此提供檢景 - 測距雙用相機原本無法實現的全方位應用，包括極長或極短焦距以及極近距離拍攝。

（訂購編號：14 642）

#### 濾鏡

新式的徠卡M型鏡頭，亦即配備標準規格濾鏡螺紋者，可選用UVa濾鏡及M型泛用式偏光鏡。

#### 電子觀景窗EVF2

EVF2提供將近100%影像區TTL再現，解析度高達1.4M像素。這不僅使精準構圖變得容易，更能全面控制所有相關資料。當現場光線條件導致難以看清楚顯示幕的畫面時，EVF2便顯得特別實用。其可傾斜的接目鏡設計使仰視拍攝更加方便。

（訂購編號 18 753）

#### 提示：

未使用其他配件（例如燈光燈、外接式觀景窗或麥克風）時，務必蓋上靴座護蓋。護蓋可在有效期間限內保護接頭28，避免滲水。

## 泛用式M型廣角觀景窗

徠卡M型泛用式廣角觀景窗是極其實用的配件。它可不受限地用在所有類比及數位徠卡M型相機上，而且（和相機的觀景窗一樣）會映出的框線，依您的選擇顯示廣角鏡頭焦距16、18、21、24或28mm的取景範圍。

此觀景窗配備了視差補償裝置，還有一個水平儀可精確校準相機的水平方位。

（訂購編號：12 011）。

## M型反射鏡式觀景窗

18、21、24mm的鏡頭都各有合適的反射鏡式觀景窗可選用，其特點是特別小巧的結構以及明亮的觀景窗畫面。如同相機的觀景窗，它們也有設定取景範圍用的框線（訂購編號18mm：12 022黑色，12 023銀色/21mm：

12 024黑色，12 025銀色/24mm：12 026黑色，12 027銀色）

。

## M型1.25倍及1.4倍的觀景窗放大鏡

使用焦距35mm以上的鏡頭時，徠卡M型1.25倍及1.4倍的觀景窗放大鏡可讓取景構圖變得容易很多。它們適用於所有徠卡M型相機，而且會放大觀景窗畫面的中心區域。此相機0.68倍的觀景窗用1.25倍的放大鏡會有0.85倍的放大效果，用1.4倍的放大鏡則有0.95倍的放大效果。

為防止遺失，有一條含簡易鎖的安全鏈可用來將觀景窗掛在揹帶的固定環上。

這些觀景窗放大鏡都附有收納皮袋。皮袋上有一個掛環，便於將觀景窗放大鏡安全地收藏在相機的揹帶上以備隨時取用。

（訂購編號12 004 M，1.25倍/12 006 M，1.4倍）

## 閃光燈

系統閃光燈徠卡SF 26，既小巧又有和相機很搭調的設計，特別適合用在此相機上。以操作容易著稱。

(訂購編號 14 622)

## M型手把

M型把手是很實用的配件，能讓您很穩固地單手握持徠卡 M Monochrom型相機，很值得推薦使用。這個把手可安裝在相機底部（取代原有的標準底蓋）。

(訂購編號：14 496)

## 多功能M型手把

多功能M型手把和M型手把相同，只是多了一條GPS天線，可將地點座標納入拍攝資料。多功能M型手把透過USB傳輸線傳送資料、以M型AC轉接頭供電、使用一般市售同步線操作閃光、透過SCA轉接頭組由TTL控制相機、使用相容閃光燈。

(訂購編號：14 495)

## 多功能M型手把的SCA轉接頭組

此轉接頭組由一個導軌及SCA連接線組成。與安裝在相機上的多功能M型手把結合後，即使閃光燈未安裝在相機上（例如用於間接照明或同時使用一個插裝式觀景窗），也可使用TTL控制的閃光功能。也可同時安裝兩個閃光，一個安裝在相機上，一個使用轉接頭組安裝。

(訂購編號：14 498)

## 麥克風轉接頭組

M型麥克風轉接頭用來在拍攝影響時進行立體聲錄音。安裝於相機配件靴座的同時，亦完成了全部必要的連接。

(訂購編號：14 634)

## 視力矯正目鏡

為了讓眼睛能夠以最佳程度適應相機的觀景窗，我們提供了下列的正或負視度值（球面）的視力矯正目鏡：± 0.5/1/1.5/2/3。

## 多功能M型手把的AC轉接頭

此電源供應器直接供應市電，讓您能長時間使用相機（須安裝多功能M型手把）。

(訂購編號：14 497)

## 多功能M型手把的指環

指環以螺紋旋在多功能M型手把或M型手把上，確保能穩穩地握持相機，在攜帶相機及使用重的長鏡頭時特別實用。

(訂購編號S：14 646/M：14 647/L：14 648)

## 相機袋

M型相機套可在運送途中保護相機，無需將相機取出護套也可拍攝，即方便又快速。為了在密集拍照時提供完善的保護，可以取下相機套的前部，而留在相機上的護套部分可繼續提供相機保護。

(訂購編號：14 547)

除此之外，還有防水布料的白金漢 (Billingham) 綜合式相機袋，可收納多種相機配備。它可收納兩個機身加兩個鏡頭，或是一個機身加三個鏡頭。即使是大型鏡頭或是裝上多功能M型把手的相機，也都有足夠的空間。設有拉鍊隔間可讓您收納徠卡閃光燈SF 26或其他配件。

(訂購編號14 854黑色，14 855鐵灰色)。

## 備用件

## 訂購編號

M型相機護蓋	14 397
M型靴座護蓋	14 644
揹帶	14 312
鋰鐵電池 BP-SCL2	14 499
充電器BC-SCL2	14 494
(含歐規及美規電源線，車用充電線)	
澳洲及英國用電源線	14 422 及 14 421

## 安全及保養須知

### 一般注意措施

- 請勿在有強力磁場及靜電或電磁波的器材（例如電磁爐、爐灶、微波爐、電視或電腦螢幕、錄影機、手持式攝影機、收音機）旁邊使用您的相機。
- 若將相機放在電視上或在電視旁操作，其磁場可能會干擾影像的紀錄。
- 同理應避免在行動電話旁使用本機。
- 強力磁場，例如揚聲器或大型電動馬達，都可能損壞儲存的資料或干擾攝影。
- 請勿在無線電發送機或高壓電線旁使用相機。其電磁場也可能干擾影像的記錄。
- 若相機因為電磁場的作用而有錯誤動作，請先關機、取出電池，並且稍後再重新開機。
- 保護相機不和殺蟲劑及其他有侵蝕性的化學品接觸。同樣的，請勿用汽油、稀釋劑或酒精清潔相機。
- 某些特定的化學藥劑和液體可能損害相機的機身，以及表面的塗層。
- 因為橡膠和塑膠有時會釋出侵蝕性化學品，所以不應和相機長時間保持接觸。
- 請您確定砂粒和灰塵不會跑進相機內，例如在海灘。砂粒和灰塵可能會損害相機和記憶卡。在更換鏡頭以及插入、取出記憶卡時，請特別注意這一點。
- 請您確定不會有水灑落相機內，例如在雪地、雨天或在海灘。濕氣可能會造成相機和記憶卡故障，甚至造成無法修復的損害。
- 未使用其他配件（例如燈光燈、外接式觀景窗或麥克風）時，務必蓋上靴座護蓋。護蓋可在有效期限內保護閃光燈靴座和接頭，避免滲水。
- 如果鹽水噴霧碰到相機（例如在海灘），請您將柔軟的毛巾先用自來水弄濕，然後徹底擰乾。隨後用一條乾布徹底擦拭。

## 顯示幕

本機監控螢幕的製程極為精密。其精密製程旨在確保總數超過 921,600 的畫素中，只有非常、非常少的暗點或亮點瑕疵。後者不算是故障，而且不會妨礙影像的重現。

- 若相機碰到溫度劇烈變化的情形，可能在顯示幕上形成冷凝潮濕現象，請用柔軟、乾燥的毛巾小心擦拭。
- 如果相機開機時外面很冷，顯示幕一開始比較暗是正常，溫度升高一些後，亮度就只會恢復正常。

## 感測器

- 高空射線（例如在飛行時）可能會引發畫素毀損。

## 冷凝濕氣

- 若相機的外部或內部有冷凝濕氣，請先關機，並將相機置於室溫一小時左右。室溫和相機溫度接近後，冷凝濕氣就會自行消失。

## 保養指示

污漬是微生物的溫床，所以，請仔細維護裝備的清潔。

### 相機

- 只能用柔軟、乾燥的毛巾清潔相機。遇有頑固汙漬，應先用稀釋得很薄的清潔劑沾濕，再用乾布擦拭。
- 相機和鏡頭上的斑點和指紋要用乾淨、不起毛球的布拭去。相機機身上不易構著的角落的粗糙汙漬，可用一根小刷子清理。同時不得碰觸快門葉片。
- 您的相機上所有軸承和滑動面都潤滑過。若長時間不使用相機，請記得：為預防潤滑位置發黏，應每三個月就啟動相機快門數次。同樣地，我們也建議您多次轉動或使用所有其他操作元件。鏡頭上的對焦環以及光圈設定環也應該偶爾轉動一下。
- 請您注意：鏡頭接座上6位元辨識碼用的感測器既不能弄髒，也不能刮傷，也請注意勿讓砂粒或類似顆粒附著於此處，以免刮傷接座。此組件只能以乾燥方式清潔，且不可對保護玻璃施力！

### 鏡頭

- 鏡頭外部鏡片通常只需用軟毛刷清除灰塵。鏡片若非常髒，可用乾淨、確定不含異物顆粒的柔軟毛巾，以畫圓圈的方式由內往外小心清潔。我們建議您使用存放於保護容器內，且可用不超過40°C的溫水清洗（不要用柔軟精，且切勿熨燙）的微纖維布（可於照相館或光學用品專賣店選購）。請勿使用浸過化學原料的眼鏡清潔布，以免傷害鏡頭的玻璃。
- 請您注意鏡頭接座上的6位元辨識碼既不能弄髒也不能刮傷，也請注意勿讓砂粒或類似顆粒附著於此處，以免刮傷接座。此組件只能以乾燥方式清潔！
- 無色的UVa濾鏡是前方鏡片處於不佳的攝影條件（例如砂子、鹽水噴濺！）時最佳的保護。不過，請別忘了：在某些逆光及高反差的環境中，其與任何其他濾鏡一樣，可能引發惱人的反光現象。使用遮光罩也能保護鏡頭避免沾到指紋或雨水。



## 電池

可重複充電的鋰離子電池是透過內部化學反應產生電流，這種反應也會受到外界溫度和空氣溼度的影響。非常高和非常低的溫度，都會縮短電池的使用時間與壽命。

- 若長時間不使用相機，請取出充電電池，否則電池可能在幾星期後放電到快沒電的程度，因為相機即使在關機狀態下，還是會消耗微小的電流（例如用來儲存日期）。否則，幾周后過度放電的電池可能會無法再充電，因為即便在關閉的狀態下，相機都會消耗少量的靜態電流（例如用於保存日期）。
- 鋰離子電池應該只能以部分充電的狀態存放，亦即是既不要完全放電也不要充飽電（顯示幕裡對應顯示的狀態）。長期儲存時，應該每年兩次為電池充電約15分鐘，以避免其電力過度流失。
- 請確保電池接點乾淨、無阻物。雖然鋰離子電池備有防止短路的措施，但其接點還是不應該與金屬（如迴紋針或飾品之類）物品接觸。短路的電池可能會變得很燙，而引發嚴重燙傷。
- 如果電池曾掉落地面，請檢查其外殼和接點是否有損壞。裝上損壞的電池可能會使相機受損。

- 若有發出氣味、褪色、變形、過熱或流出液體的現象發生，務必立刻將該電池從相機或充電器取出，改用其他電池。繼續使用這樣的電池可能引發過熱現象、火災及 / 或爆炸！
- 有液體流出或有燒焦的味道時，務必讓該電池遠離熱源。那些流出的液體有可能會著火！
- 充電電池內的安全閥應確保釋放，因不當操作或其他原因所產生的過度壓力。
- 電池的壽命是有限的。建議在使用四年後更換。
- 請將受損的電池交給資源回收點回收。
- 充電電池不得長時間暴露於熱源或日曬、溼度或濕氣之下，亦不得置於微波爐或高壓容器內，否則會有失火或爆炸的危險！

## 充電器

- 充電器僅能在室內使用。
- 若在收音機附近使用充電器，訊號的接收可能受到干擾；這些裝置之間至少要維持一公尺的距離。
- 使用充電器時，可能有聲音出現（「唧唧聲」），這是正常現象，並不是故障。
- 充電器不使用時，請拔除電源，因為即使未放入電池還是會消耗一些（很少的）電流量。
- 充電器的接點應該保持乾淨，而且絕對不要讓它們短路。
- 本機隨附的車用充電線
  - 只能使用12V電源，
  - 不可連接已接上市電網路的充電器。

## 記憶卡

- 在儲存相片或是讀取記憶卡的過程中，不能將記憶卡取出、將相機關機或是劇烈震動。
- 基本上，為了保險起見，記憶卡只能存放在附贈的抗靜電容器內。
- 請勿將記憶卡存放在曝露於高溫、直接日曬、磁場或靜電的場所。
- 請勿讓記憶卡掉落地面，而且不要彎折，否則可能會受損，而且可能導致儲存的資料遺失。
- 如果長時間不使用相機，請將記憶卡取出。
- 請勿接觸記憶卡背面的觸點，並避免讓它們沾上汗漬、灰塵或濕氣。
- 我們建議您偶爾將記憶卡格式化，因為刪除資料而引發的記憶體破碎現象多少會影響記憶體的功能。

**提示：**

- 用簡單格式化的方法時，記憶卡上存在的資料並不是真的失去而無法回復，而是將目錄刪除，讓現有的檔案無法直接存取。有些相關軟體能還原這些資料。只有那些被新儲存的資料覆寫的資料，才會真正被徹底消除。儘管如此，仍應養成習慣將您的相片儘快轉存到安全的儲存裝置，例如您電腦的硬碟。需將相機連同記憶卡一起送修時，尤應採取此安全措施。
- 格式化過程最長可花上三分鐘的時間（確實時間因各種記憶卡而異）。

## 清潔感測器/灰塵辨識

若有灰塵或髒汗微粒附著在感測器表面玻璃上，大一些的微粒可能會在相片上形成黑點或斑點。

可使用 **Dust detection** 功能檢查感測器表面是否有塵粒及其多寡。這種方法比目視法準確許多，可據此判斷是否需要清潔感測器。

您可將相機送至徠卡相機公司的顧客服務部（地址：請看第124頁），客戶服務部門進行付費的感測器清潔工作；這項清潔工作並非保固服務的一部分。

您也可以自行進行這項清潔。選單裡有相關功能：**Sensor cleaning**。快門會被強制於開啟狀態，以便您清潔感測器。

### 灰塵辨識

- 從主選單（請看第26/116頁）選擇 **Sensor cleaning**（第4頁，**SETUP**區域）。
  - 相關子選單隨之出現。
- 選擇 **Dust detection**。
  - 顯示幕會顯示下列訊息：**Attention Please close the aperture to the largest value [16 or 22], and take a picture of a homogeneous surface [defocussed]**。
- 按下快門鈕。
  - 不久後顯示幕上會出現一個「圖像」，並以黑色像素代表塵粒。

### 提示：

若無法進行灰塵辨識，將會出現一則相應的訊息。畫面會在幾秒鐘後切換回第2點描述的訊息。接著便可重複進行拍攝。

### 清潔

- 從主選單（請看第26/116頁）選擇 **Sensor cleaning**（第4頁，**SETUP**區域）。
  - 相關子選單隨之出現。
- 選擇 **Open shutter**。
- 選擇 **Yes**。若電池電力足夠（即至少60%的電力），快門隨之打開。
  - 隨即出現下列指示：**Please switch off camera after cleaning**。

### 提示：

若電池電力太低，會出現警告訊息 **Attention Battery capacity too low for sensor cleaning**，表示無法使用該功能，亦即無法選擇 **Yes**。

- 進行清潔工作。此時務必要注意提示底下的說明。
- 清潔完成後，請將攝像機關閉。為保安全，快門將在 10 秒後關閉
  - 會出現下列提示：**Attention Please stop sensor cleaning immediately**。

**提示：**

- 原則上：為了防止灰塵等侵入相機內部，相機應該要一直裝著鏡頭或有機身蓋罩著。
- 基於同樣理由，更換鏡頭的動作應迅速，而且儘可能在無塵的環境中進行。
- 塑膠零件容易產生靜電並因此吸附灰塵，所以鏡頭蓋和機身蓋應該盡量不要在衣物口袋裡放太久。
- 感測器的檢查和清潔都應該儘可能在無塵環境中進行，以避免又弄髒它。
- 輕微附著的灰塵，可用乾淨或甚至離子化的氣體（例如空氣或氮氣）從感測器表面玻璃上吹掉。最好是用沒有刷子的（橡膠）風球。合適的低壓清潔噴劑，例如「Tetenal Antidust Professional」的產品，也可依其說明使用。
- 若用前述方式無法去除附著的顆粒，則請和徠卡資訊服務部門。
- 電池電力若在快門處於開啟狀態時降到40%以下，監控螢幕會出現警告訊息：**Attention Please stop sensor cleaning immediately**。在這同時，相機會發出嗶聲，直到相機關機為止。快門會隨著相機的關機關閉。
- 務必注意：在這種情形下快門窗不能有東西妨礙快門正常關閉，以避免發生損害！

**重要：**

- 徠卡相機公司不為使用者清潔感測器所造成的損害提供保固服務。
- 請勿嘗試用嘴巴向感測器表面玻璃吹氣去除灰塵顆粒，即使最小的唾液滴都可能引發難以去除的斑點。
- 切勿使用高壓的氣動清潔工具，以免造成損害。
- 進行檢查和清潔時，請小心避免讓任何堅硬物體碰觸到感測器表面。

## 存放

- 若長時間不使用相機，建議
  - a. 取出記憶卡 (請看第18頁)
  - b. 取出電池(請看第16頁)，(最遲2個月後失時間及日期資料。
- 直射陽光從正前方照到相機時，鏡頭會發揮猶如聚焦鏡的效力。所以必須保護相機，避免受到日光直曬。裝上鏡頭蓋、將相機置於陰影下 (或是放進袋子裡)，有助於避免相機內部發生損害。
- 請您將相機存放在封閉和有軟墊的容器內，這樣就不會擦傷而且也可以防灰塵。
- 將相機存放在乾燥、通風良好而且不會暴露於高溫 and 濕氣的場所。在潮濕環境使用過相機後，要收起來之前，務必先將濕氣清除掉。
- 使用中弄濕的相機袋應該先騰空，以避免濕氣和可能析出的製革劑殘渣對您的裝備造成損害。
- 為了防止在濕熱的熱帶氣候使用時受到真菌侵染，相機裝備應儘可能避免暴露於大量的陽光與空氣中。唯有加入乾燥劑例如矽膠凝體時，才建議用密封的容器或袋子收藏。
- 為避免霉菌侵染，亦不宜長時間將相機存放在皮袋內。
- 請記錄您的相機和鏡頭的工廠序號 (刻在配件靴座上)，萬一遺失時此點為非常重要線索。

## 故障及其排除方式

### 相機開機時沒反應。

- 有裝入電池嗎？
- 電池的電力充足嗎？  
請使用充飽電的電池。
- 有正確裝上底蓋嗎？

### 相機開機後直接關機。

- 電池的電量足以供相機作業嗎？  
請為電池充電，或是換上一顆充飽電的電池。
- 有冷凝濕氣嗎？  
將相機從很冷的地方拿到溫暖處，就會出現這種現象。發生此情況時，請等到冷凝濕氣蒸發後再開機。

### 相機無法觸發快門。

- 相機正在將影像資料傳送到記憶卡上，而且緩衝記憶體已滿。
- 記憶卡容量已用完，而且緩衝記憶體已滿。  
請先刪除不再需要的相片。
- 沒有插入記憶卡，而且緩衝記憶體已滿。

### 無法儲存相片。

- 有插入記憶卡嗎？
- 記憶卡的容量用完了。  
請先刪除不再需要的相片。

### 監控螢幕太暗或太亮。

- 視線與螢幕的角度很大時，受限於螢幕製作原理，會比較難以看清楚螢幕上的畫面。  
若直視螢幕時，仍覺得太亮或太暗：請設定其他亮度，或使用隨附的外接式電子觀景窗EVF2（請看第94頁）。

### 剛拍攝的相片無法在顯示幕上顯示。

- 將相機轉到攝影模式後) **Auto Review**功能開啟了嗎？

### 無法播放相片。

- 有插入記憶卡嗎？
- 記憶卡上沒有資料。

### 與電腦連接（透過安裝在相機上的多功能手把）後，無法傳送資料。

- 請檢查相機、電腦及多功能M型手把的連結是否正確。

### 時間和日期資料錯誤或是不存在。

- 相機長時間沒有使用（裡面沒電池時，更容易發生這種狀況）。  
請裝入充飽電的電池。  
設定日期和時間。

## 附件

## 觀景窗內的顯示

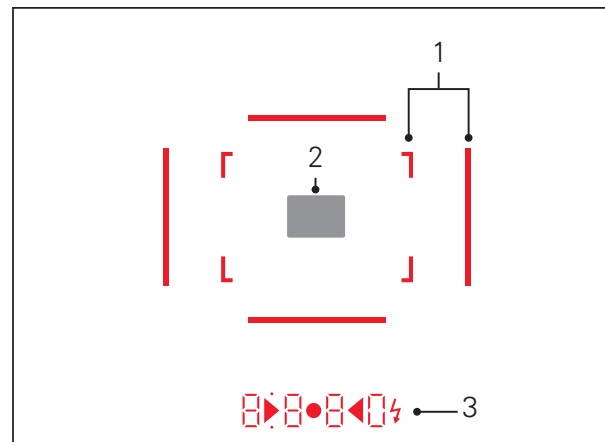



1. 用於50mm及75mm<sup>1</sup>的框線 (例子)
2. 焦距設定的測量區
3. 藉由 LED<sup>1</sup> (發光二極體) 顯示：
  - a. 四位數數位顯示，以及位於上方和下方的點狀數位燈號：
 

**8 8 8 0** 數位顯示：

    - 使用光圈先決功能A時，會顯示相機自動設定的快門時間；快門時間超過1秒時，則顯示其流程
    - 光圈先決A下，超出及未達測光和設定範圍時的警告訊息
    - 顯示曝光修正值 (設定時瞬間顯示，或在輕按快門鈕啟動測光功能時顯示約0.5秒)
    - 提示緩衝記憶體 (暫時) 已滿
    - 提示未安裝記憶卡 (Sd)
    - 提示記憶卡已滿 (Full)
  - b. ■ 上方點狀燈號：
    - 提示使用測光值儲存功能(恆亮)
  - c. ■ 下方點狀燈號：
    - (閃爍) 告示：
  - d. ▶ ● ◀ 正在使用曝光修正
    - 兩個三角形及一個圓形的LED訊號燈：手動曝光設定時：共同作為曝光平衡的光量計顯示元件三角形LED會提示您，該往哪個方向旋轉光圈環及快門時間轉盤，以調整出適當的曝光。
    - 低於測量範圍的警示
  - e. ⚡ 閃光符號：
    - 閃光燈處於待命狀態
    - 攝影前後閃光燈曝光的數據資料

<sup>1</sup>提供自動亮度控制功能，會隨外界亮度而調整。含觀景窗座的徠卡M型鏡頭無法執行此自動控制功能，因為會遮住為該功能提供對應資訊的亮度感測器5。在這種情況下，相機會以固定的亮度顯示取景框線及訊息。

## 觀景窗內的顯示

## 攝影時

## 實時取景模式



- 1** 曝光作業模式
- 2** 快門時間
- 3** 測光方法
- 4** ISO感光度
- 5** 儲存測量值
- 6** 曝光修正

(點測光的額外功能)

- 7** 測光範圍

(1-7的額外功能, 適用於拍攝影片)

- 8** 拍攝計時
- 9** 拍攝計時訊息 (閃爍)

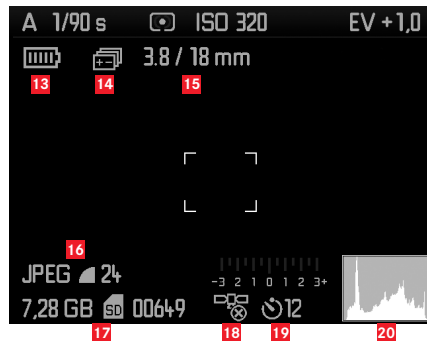
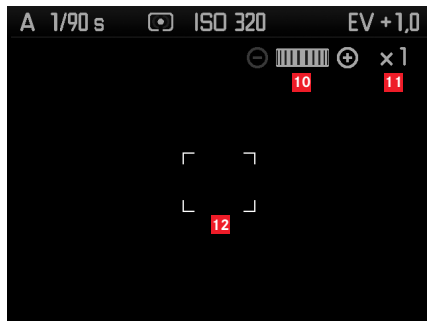

(1-9的額外功能，透過鏡頭對焦或按Fokus按鈕；13-17的替代功能；不適用於拍攝影片)

- 10** 轉盤符號 / 可用的放大 / 縮小倍率
- 11** 目前使用的放大倍率
- 12** 局部放大畫面的框線

(1-10的額外功能，透過按INFO按鈕；13-15為10-12的替代功能)

- 13** 電池電力
- 14** 包圍曝光
- 15** 光傳量 / 焦距或鏡頭型號
- 16** 檔案格式 / 壓縮 / 解析度或影片格式  
(視拍攝類型而定)
- 17** 剩餘的記憶卡容量 / 拍攝張數或時間  
(視拍攝類型而定)
- 18** GPS狀態 (必須先安裝多功能M型手把)
- 19** 自拍狀態 / 前置時間
- 20** 攝影色階分布圖 (不適用於拍攝影片)

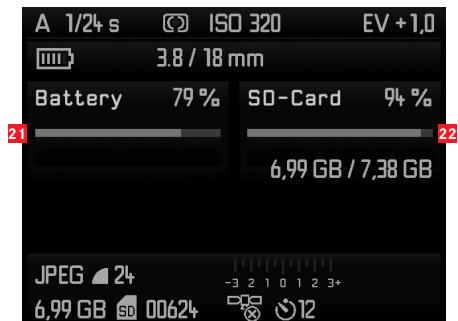

在觀景窗模式下，透過按INFO按鈕

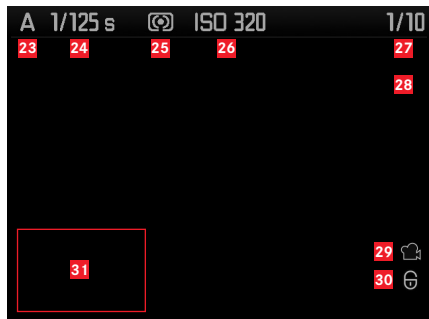

(1-7/13-21的額外功能)

- 21** 電池電力
- 22** 記憶卡容量



- 23** 曝光作業模式
- 24** 快門時間
- 25** 測光方法
- 26** ISO感光度
- 27** 所顯示相片的編號 / 記憶卡上的相片總數
- 28**  放大功能標誌 / 顯示截圖大小和位置 (僅適於截圖, 其它顯示訊息忽略)
- 29** 拍攝影片符號
- 30** 相片的防刪除保護符號
- 31**  被選取的相片 (只適用於同時播放4/9/36張縮圖時)

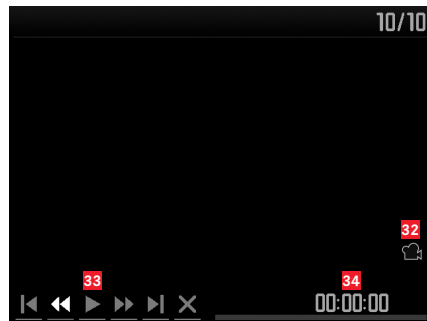

(24-33的額外功能, 透過按INFO按鈕, 適用於拍攝影片)

- 32** 播放影片符號
- 33** 影片控制符號
- 34** 進行的播放時間 / 進度列

## 色階分佈圖

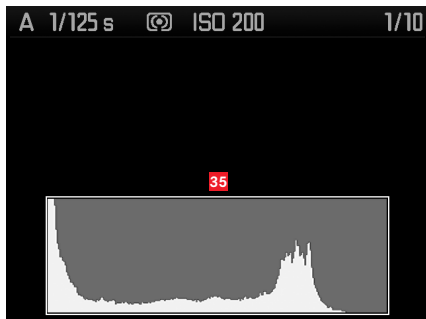

(同24-36, 額外功能)

**35** 色階分佈圖

## 消波部位顯示



(同24-36, 沒有影像內容的部位閃紅 / 藍燈, 額外功能)

**36** 削波符號

## 額外資訊



(28-37的額外功能，透過按INFO按鈕，畫面縮小)

- 37 使用者設定檔編號 / 名稱
- 38 日期
- 39 時間
- 40 資料夾編號 / 檔案名稱
- 41 檔案格式 / 壓縮 / 解析度或影片格式 (視拍攝類型而定)
- 42 曝光修正
- 43 光傳量 / 焦距
- 44 拍攝影片符號
- 45 相片的防刪除保護符號 (只有在相應的相片上才會出現)
- 46 GPS狀態 (僅在裝上多功能M型把手的情況下顯示)
- 47 閃光攝影符號 (不適用於拍攝影片)

## 選單操控

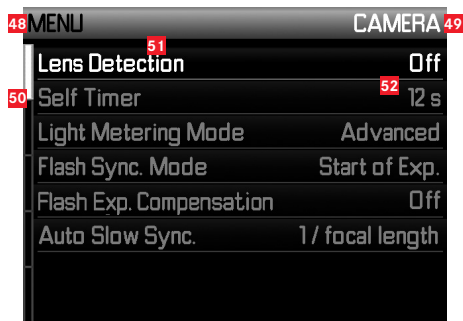

- 48 選單說明，MENU = 主選單 / SET = 攝影參數選單
- 49 選單區域說明 (僅限主選單)
- 50 跑馬燈及頁面標記 (僅限主選單)
- 51 選單項目
- 52 設定選單項目

## 選單項目

## 主選單 (MENU按鈕)

**CAMERA** 區域 (頁面1)

Lens Detection	請看第34頁
Self Timer	請看第68頁
Light Metering Mode	請看第51頁
Flash Sync. Mode	請看第64頁
Flash Exp. Compensation	請看第63頁
Auto Slow Sync.	請看第58頁

**IMAGE** 區域, 第2頁

Sharpness	請看第39頁
Contrast	請看第39頁
Toning	請看第39頁
Shading Correction	請看第35頁
DNG compression	請看第36頁

**SETUP** 區域, 第3頁

Monitor Brightness	請看第44頁
EVF Brightness	請看第44頁
Frameline color	請看第40頁
Focus Peaking	請看第49頁
Focus Aid	請看第48頁
Clipping Definition	請看第79頁
Auto Review	請看第75頁

**SETUP** 區域, 第4頁

Copyright Information	請看第68頁
Image Numbering	請看第87頁
Horizon	請看第45頁
Sensor Cleaning	請看第104頁
GPS	請看第69頁
Audio	請看第67頁
Exposure Simulation	請看第45頁



**SETUP** 區域, 第5頁

Auto Power Off	請看第32頁
Date / Time	請看第30頁
Acoustic Signal	請看第33頁
Language	請看第30頁
USB Mode	請看第89頁
Reset	請看第73頁
Format SD card	請看第88頁
Firmware	請看第93頁

**攝影參數選單 (SET按鈕)**

ISO	請看第37頁
File Format	請看第35頁
JPEG Resolution	請看第35頁
Video recording	請看第36頁
Exposure bracketing	請看第66頁
Exposure compensation	請看第54頁
Exposure metering	請看第50頁
User profile	請看第71頁

## 關鍵字索引目錄

DNG .....	35/119	固件下載 .....	93
GPS .....	69	地平線 .....	45
ISO感光度 .....	37	多功能M型手把 .....	94
M型手把 .....	94	存放 .....	106
M型麥克風轉接頭 .....	94	實時取景模式 .....	44/48
R型轉接頭M .....	94	將記憶卡格式化 .....	88
SCA 轉接頭套件 .....	94	將資料傳送到電腦 .....	89
主開關 .....	22	對焦 .....	46
交換式鏡頭 .....	19/94	分割影像法 .....	47
交換式鏡頭 .....	19/98	混合影像法 .....	47
儲存測量值 .....	53	測光範圍 .....	40/108
光圈先決 .....	52	測距 .....	46
手動設定 .....	58	設定轉盤 .....	8
曝光修正 .....	54	銳利度設置幫助 .....	49
測光範圍 .....	59	顯示幕上 .....	48
自動包圍曝光 .....	56	小心提示 .....	98
超出或低於測量範圍 .....	59	影像特性 (對比、銳利度) .....	39
選擇測光方法 .....	50	影像頻率 .....	24
開機 .....	50	徠卡M型鏡頭 .....	19
保護相片 / 取消防止刪除功能 .....	84	使用之前的鏡頭 .....	19
保養指示 .....	98	安裝和拆卸 .....	21
備用件 .....	97	結構 .....	8
充電電池的安裝和取出 .....	16	徠卡產品支援服務 .....	124
光圈先決 .....	52	徠卡顧客服務 .....	124
光圈設定環 .....	8	快門鈕, 請看快門和技術資料 .....	23/119
出貨內容 .....	123	快門, 參閱快門鈕和技術資料	
刪除相片 .....	82	感光度 .....	37
原始資料 (DNG) .....	36/92	技術資料 .....	119
取景框線 - 測距觀景窗 .....	40	拍攝影片 .....	66
各部件名稱 .....	8	摺帶 .....	12
回復所有個別菜單設定 .....	73	播放模式 .....	74
		放大相片 .....	81
		故障及其排除方式 .....	106

時間/光圈組合，請參閱曝光設置		警告提示.....	6
時間和日期 .....	30	連續拍攝.....	24
時間設定轉盤 .....	25	選單操控功能 .....	26
景深刻度.....	8	選單語言.....	30
格式框架.....	40	選單項目.....	116
檔案格式.....	35	錄音.....	67
檢視相片		閃光燈模式.....	60
使用Auto Review功能.....	75	HSS閃光.....	64
實用播放功能.....	74	同步.....	64
水平儀.....	45	閃光燈.....	60/94
清晰度，請參閱影像特性		閃光燈曝光修正值.....	63
測距儀，參閱圖像特性		開機/關機.....	22
漸暈修正.....	35	電子觀景窗.....	94
濾鏡.....	94	顯示幕.....	44
版權.....	68	顯示訊息	
畫面，選擇播放模式		觀景窗內.....	108
相機袋.....	94	顯示幕上的顯示.....	110
維修/徠卡顧客服務.....	124		
聲音.....	39		
聲音（按鍵聲）.....	33		
設定音量.....	33		
自動開機.....	32		
自拍設定.....	68		
色彩飽和度（HSS）.....	64		
色階分佈圖.....	78/114		
視力矯正目鏡.....	94		
視野撥桿.....	42		
觀景窗.....	40		
加裝式觀景窗.....	94		
取景框線.....	40/108		
顯示訊息.....	108		
解析度.....	36		
記憶卡的裝入和取出.....	18		

## 技術資料

### 相機型號

Leica M Monochrom (Typ 246), 小巧的數碼檢景 - 測距雙用相機, 配有黑白傳感器

### 鏡頭連接

徠卡M型接座, 加上額外的6位元辨識碼用感測器。

### 鏡頭系統

從16 - 135mm的徠卡M型鏡頭。

### 攝影格式/影像感測器

黑白CMOS晶片, 有效面積約23.9 x 35.8mm (相當於可用的類比徠卡M型格式), 無彩色和低通濾鏡

### 解析度

DNG™: 5976 x 3992 像素 (24MP),

JPEG: 5952 x 3968 像素 (24MP), 4256 x 2832 像素 (12MP), 2976 x 1984 像素 (6MP), 1600 x 1072 像素 (1.7MP);

拍攝影片: 720P, 1080P

### 資料格式

DNG™ (原始資料)、可選擇壓縮或不壓縮 (無損失), JPEG

### 檔案大小

DNG™: 壓縮20-30MB, 未壓縮34.5MB,

JPEG: 視解析度與相片內容而定。

### 影片拍攝格式

動作 JPG/Quicktime

### 影片圖像頻率

24B/s, 25B/s

### 緩衝記憶體

2GB / 30 每系列

### 錄音

單音, 立體聲 (透過麥克風轉接頭) (請看第97頁), 可在拍攝時選擇自動或手動控制或固定設定「演唱會模式」選項。

### 儲存媒體

最高到2GB的SD卡 / 最高到32GB的SDHC卡 / SDXC卡。

### 選單語言

德文、英文、法文、西班牙文、義大利文、日文、繁體中文、簡體中文、俄文、韓文。

### 相容性

Windows® Vista® SP2/ 7® / 8® ; Mac® OS X (10.6或以上)

### 測光模式

使用工作光圈透過鏡頭 (TTL) 進行測光; 針對系統相容型 SCA-3000/2標準閃光燈的閃光曝光, 進行中間重點式TTL測光

### 測光原理/方法

測量從第1道快門簾幕上明亮葉片反射在測光元件上的光線: 中央重點式測光; 在感測器上測光: 點測光、中央重點式測光、多區測光

### 測光範圍

(對於 ISO320, 室溫和正常空氣濕度:) EV0 (如果光圈是 1.0) 至 EV20 (如果光圈是 32) 觀景窗內左側的三角形LED閃爍標示超出測量範圍下限

## 感光度範圍

ISO 320 至 ISO PUSH25000，可設定至 $\frac{1}{3}$  ISO級數，可選擇自動控制或手動設定

## 曝光作業模式

可在手動光圈預選 - 光圈先決A條件下自動控制快門時間，或選擇手動設定快門時間與光圈。

## 閃光燈曝光操控

### 閃光燈接頭

使用有中央及操控接點的配件靴座，或使用SCA轉接頭組（請看第96頁）

### 同步

可選定在第一或第二道快門簾幕

### 同步時間

 =  $\frac{1}{180}$ 秒；若低於同步時間，可使用更長的快門時間：自動切換為TTL線性閃光模式，包括具HSS功能的徠卡系統閃光燈

### 閃光燈測光

（用SCA-3502-M5轉接頭或符合SCA-3000標準的閃光燈，例如徠卡SF 26）：用TTL預閃測光功能

### 閃光燈測光元件

2顆矽基光電二極體連同聚光鏡位於相機底部

## 閃光燈曝光修正值

$\pm 3\frac{1}{3}$  EV in  $\frac{1}{3}$  EV 等級可通過菜單或相應配備的徠卡系統閃光燈設置

閃光燈模式的訊息顯示（僅限觀景窗內）

待命狀態：觀景窗內閃光燈符號LED持續發亮，

## 觀景窗

### 觀景窗原理

大型、明亮取景框線的測距觀景窗，含自動視差補償功能。

### 目鏡

目鏡調整成-0.5視度；可選購-3至+3視度的視力矯正目鏡。

### 畫面範圍

以每兩組取景框線發亮加以表示：適用於35及135mm、適用於28及90mm或適用於50及75mm；安裝鏡頭後自動切換；可從選單選擇取景框線的顏色

### 視差補償

觀景窗和鏡頭之間、水平方向及垂直方向的誤差可以自動補償，也就是說，可以對應於當時的對焦狀態，把取景範圍自動涵蓋在取景框線內

## 觀景窗和實際畫面的吻合度

若距離設定為2m，取景框線的尺寸正好等於感測器的尺寸（約23.9 x 35.8mm）；設定為無限遠時，視焦距的不同，感測器的捕捉範圍會比取景框線顯示的範圍大約7.3%（28mm）至18%（135mm）；相反的，若距離設定短於2m，捕捉範圍亦隨之縮小

**放大**（適用於所有鏡頭）

0.68倍

## 基線很長的測距儀

使用分割影像法和混合影像法，對焦區在觀景窗的中央（一個特別明亮的區域）

## 有效基線

47.1mm（機械基線69.25mm x 觀景窗 放大倍率0.68x）

## 顯示訊息

### 觀景窗內

四位數數位顯示，以及位於上方和下方的點狀數位燈號，請看第108頁的顯示訊息

### 在背蓋上

3" TFT 液晶顯示屏幕擁有 16 百萬全彩色和 921,600 像素，接近 100% 影像區，最大 170° 觀察角度，通過一塊由超強、耐刮的藍寶石玻璃製成的保護玻璃遮擋防護，適於實時取景及播放模式，顯示訊息請看第110頁。

## 快門及觸發

### 快門

金屬葉片狹縫快門，垂直動作

### 快門時間

光圈先決：(A)無段變化從60秒至 $\frac{1}{4000}$ 秒。

手動設定時：8秒至 $\frac{1}{4000}$ 秒，以半格為單位。

B：長時間曝光攝影最大至60秒（搭配自拍器的T功能，也就是說第一次按快門鈕 = 快門開啟；第二次觸發快門 = 快門關閉），

⬅️ ( $\frac{1}{180}$ 秒)：閃光同步功能的最短快門時間，HSS線性閃光模式允許小於 $\frac{1}{180}$ 秒的所有快門時間（使用具HSS功能的徠卡系統閃光燈）；拍攝影片時（光圈先決與手動模式）： $\frac{1}{30}$  到  $\frac{1}{4000}$ 秒，適用於手動模式或強制接管控制目前快門時間，以確保正確曝光。

### 快門上絃

使用內建馬達，只會發出輕微的聲音。

### 連續拍攝

每秒3張相片，一次不超過30張相片。

### 快門鈕

單張拍攝：兩段式。第1段啟動測光功能及測光值儲存（在光圈先決之下），第二次觸發快門；內嵌快門線用標準螺紋。

### 自拍設定

前置時間可選擇2秒（使用光圈先決及手動設定曝光模式）或12秒，透過選單進行設定，以相機正面閃爍的發光二極體（LED）以及顯示幕裡對應的顯示訊息顯示。

## 相機的開機/關機

使用相機頂蓋上的主開關、可選擇在2/5/10分鐘後自動關閉相機電子系統、輕按快門鈕即可再度啟動相機。

## 電源

1顆鋰離子電池，公稱電壓7.4伏特，容量1800mAh，顯示幕上的容量顯示，快門時常打開時（為了清潔感光元件）會在電力快用完時發出警告聲響，最大充電電流 / 電壓：直流電，1100mA / 8.25V；型號：BP-SCL2，製造商：VARTA Microbattery，製造地點：印尼

## 充電器

輸入：交流電100-240V，50/60Hz，300mA，自動切換，或是直流電12V，1.3A；輸出：直流電，7.4V，1000mA；型號：BC-SCL2，製造商：Guangdong PISEN Electronics Co., Ltd.，製造地點：中國

## GPS

可關閉（必須先安裝多功能M型手把，請看第96頁），由於某些國家法令的限制，會自動在那些地區強制關閉，資料會儲存在相片檔案的EXIF標頭裡。

## 水平儀

以3段式加速感測器測量，測量範圍：俯仰傾（以橫軸為中心）及側傾（以縱軸為中心）各  $\pm 90^\circ$ ，測量準確度/顯示敏感度： $\leq 1^\circ$ （0-40 $^\circ$  C）且在水平方向，於顯示幕上顯示

## 相機機身

### 材質

全金屬外殼以壓鑄鎂合金製成，合成皮套，頂蓋及底蓋以黃銅製成，兩者都有黑色鍍鉻的表面處理

### 視野撥桿

可以讓人隨時手動檢視取景框線的配對（例如為了比較構圖）。

### 腳架螺紋

A ¼ (¼") DIN以貴金屬製成，位於底部。

### 操作條件

0到40 $^\circ$  C

### 連接介面

ISO閃光燈靴座、配件靴座、多功能M型手把的接點列。

### 尺寸

（寬x深x高）：約138.6 x 42 x 80mm

### 重量

680公克（含充電電池）

## 出貨內容

充電器（100-240V）含2條電源線（歐規、美規，在某些出口市場可能不同），以及1條車用充電線、鋰離子充電電池、背帶、鏡頭接座 - 機身護蓋，閃光燈靴座 / 配件靴座護蓋，Adobe® Photoshop® Lightroom® 權限

我們保留變更設計、規格及出貨內容的權利。

## LEICA PRODUCT SUPPORT

徠卡相機股份公司使用者服務部門會以書面、電話或電子郵件的方式，回答您關於徠卡產品應用技術方面的問題。

該部門也負責選購諮詢以及使用說明書的訂閱事宜。您可透過徠卡相機股份公司網站上的聯絡表格與我們聯繫。

徠卡相機股份公司

產品支援服務 / 軟體支援服務

Am Leitz-Park 5

D-35578 Wetzlar

電話：+49(0)6441-2080-111 /-108

傳真：+49(0)6441-2080-490

info@leica-camera.com / software-support@leica-camera.com

## LEICA CUSTOMER CARE

徠卡相機股份公司的顧客服務部門或徠卡的地區代理維修服務部門（地址請參閱保證書），會負責您徠卡裝備的相關保養及損壞之維修服務。

徠卡相機股份公司

顧客服務

Am Leitz-Park 5

D-35578 Wetzlar

電話：+49(0)6441-2080-189

傳真：+49(0)6441-2080-339

customer.care@leica-camera.com





# Leica M Monochrom

Instructions

## FOREWORD

Dear Customer,

Leica would like to thank you for purchasing the Leica M Monochrom and congratulate you on your choice. With this unique digital view and range finder camera, you have made an excellent choice.

We wish you a great deal of pleasure and success using your new camera.

In order to make best use of all the opportunities offered by this high performance camera, we recommend that you first read these instructions.

### Notes:

- Leica is constantly working on the further development and optimization of the Leica M Monochrom. As digital cameras have many functions that are software-controlled, improvements and enhancements to the functions can be installed on the camera at a later date. To do this, Leica releases what are known as firmware updates at irregular intervals. Cameras are always supplied from the factory with the latest firmware, but you can easily download the updates to your camera yourself from our website.

If you register as an owner on the Leica Camera website, you will receive a newsletter informing you when a new firmware update is available. You will find more information on registration and firmware updates for your camera, as well as changes and additions to the operating instructions, in the "Customer" area at: <https://owners.leica-camera.com>

To check whether your camera is running the latest firmware version, select **Firmware** in the main camera menu (section **SETUP**, see p. 150, 240).

- Before using your camera for the first time, please check that the accessories supplied are complete.

This is a Class B product based on the standard of the Voluntary Control Council for Interference from Information Technology Equipment (VCCI). If this is used near a radio or television receiver in a domestic environment, it may cause radio interference. Install and use the equipment according to the instruction manual.

#### FCC Note:

This equipment has been tested and found to comply with the limits for a Class B digital device, pursuant to Part 15 of the FCC Rules. These limits are designed to provide reasonable protection against harmful interference in a residential installation. This equipment generates, uses, and can radiate radio frequency energy and, if not installed and used in accordance with the instructions, may cause harmful interference to radio communications. However, there is no guarantee that interference will not occur in a particular installation. If this equipment does cause harmful interference to radio or television reception, which can be determined by turning the equipment off and on, the user is encouraged to try to correct the interference by one or more of the following measures:

- Reorient or relocate the receiving antenna.
- Increase the separation between the equipment and receiver.
- Connect the equipment into an outlet on a circuit different from that to which the receiver is connected.
- Consult the dealer or an experienced radio/TV technician for help.

#### FCC Caution:

To assure continued compliance, follow the attached installation instructions and use only shielded interface cables with ferrite core when connecting to computer or peripheral devices. Any changes or modifications not expressly approved by the party responsible for compliance could void the user's authority to operate this equipment.

Trade Name:	LEICA
Model No.:	LEICA M MONOCHROM (Typ 246)
Responsible party/ Support contact:	Leica Camera Inc. 1 Pearl Count, Unit A Allendale, New Jersey 07401 Tel.: +1 201 995 0051 Fax: +1 201 995 1684 technicalinfo@leicacamerausa.com

This device complies with Part 15 of the FCC Rules. Operation is subject to the following two conditions: (1) This device may not cause harmful interference, and (2) this device must accept any interference received, including interference that may cause undesired operation.

#### LEICA M MONOCHROM (Typ 246)



Tested To Comply  
With FCC Standards

FOR HOME OR OFFICE USE

#### For Canada only:

CAN ICES-3 (B)/NMB-3(B)

## CONTENTS

Warning notes.....	130
Legal information .....	130
Disposal of electrical and electronic equipment.....	131
Designation of parts.....	132
Quick-start guide .....	134
Comprehensive instructions	
Preparations	
Attaching the carrying strap .....	136
Charging the battery .....	137
Replacing the battery and memory card .....	140
Leica M lenses .....	143
Attaching.....	145
Detaching.....	145
The most important settings / Controls	
Turning the camera on and off .....	146
Shutter release button .....	147
Serial exposures .....	148
Shutterspeed dial .....	149
Menu control .....	150
Presets	
Basic camera settings	
Menu language .....	154
Date and time .....	154
Automatic power off .....	156
Signal tones .....	157
Basic picture settings	
Lens type detection .....	158
Vignetting (Shading) correction.....	159
File format .....	159
Resolution .....	160
ISO sensitivity .....	161
Image properties / contrast, sharpness .....	163
Toning.....	163
Bright-line view and range finder .....	164
Frame selector .....	166
Monitor .....	168
Live View mode .....	168
Horizon.....	169

Distance setting .....	170	Additional functions	
With the optical rangefinder .....	170	Folder management .....	210
With the monitor image in Live View mode .....	172	Formatting the memory card .....	212
With indication of in-focus subject details .....	173	Transferring data to a computer .....	213
Turning the exposure meter on / off .....	174	Adobe® Photoshop® Lightroom® .....	216
Exposure metering methods .....	174	Leica Image Shuttle® .....	216
Exposure modes .....	176	Working with DNG raw data .....	216
Aperture priority .....	176	Installing firmware updates .....	217
Exposure lock .....	177	Miscellaneous	
Exposure compensation .....	178	System accessories .....	218
Automatic bracketing .....	180	Spare parts .....	221
Manual exposure setting .....	182	Precautions and care instructions	
The <b>B</b> setting / The T function .....	182	General precautions .....	222
Values above and below the metering range .....	183	Care instructions .....	224
Flash mode .....	184	Cleaning the sensors / dust detection .....	228
Additional functions		Storage .....	230
Video recordings .....	190	Malfunctions and their resolution .....	230
Sound recording .....	191	Appendix	
Taking photographs with the self-timer .....	192	Displays .....	232
Marking the picture files for copyright protection .....	193	Menu items .....	240
Recording the location with GPS .....	193	Index .....	242
User/application-specific profiles .....	195	Technical data .....	244
Resetting all custom settings .....	197	Leica Service addresses .....	248
Review mode .....	198		

**The CE identification of our products documents complies with the fundamental requirements of the valid EU directives.**

## WARNING MESSAGES

- Modern electronic elements react sensitively to electrostatic discharge. As you can easily pick up charges of tens of thousands of volts, by walking on synthetic carpets for example, a discharge can occur when you touch your camera, particularly if it is placed on a conductive surface. If only the camera housing is touched, this discharge is harmless to the electronics. However, despite built-in safety circuits, the outer contacts, such as the battery or rear panel contacts, should not be touched if at all possible for safety reasons.
- For any cleaning of the contacts, do not use an optical micro-fiber cloth (synthetic); use a cotton or linen cloth instead. Before touching the contacts, you can make sure you discharge any electrostatic charge by deliberately touching a heating or water pipe (conductive, earthed material). You can also avoid soiling and oxidization of the contacts by storing your camera in a dry place with the lens or bayonet cap attached.
- Use only the recommended accessories to prevent faults, short circuits or electric shock.
- Do not attempt to remove parts of the housing (covers); qualified repairs can be carried out only at authorized service centers.

## LEGAL INFORMATION

- Please ensure that you strictly observe copyright laws. The recording and publication of pre-recorded media such as tapes, CDs, or other published or broadcast material may contravene copyright laws.
- This also applies to all of the software supplied.
- The SD, HDMI, and USB logos are registered trademarks.
- Other names, company or product names referred to in this manual are trademarks or registered trademarks of the relevant companies.



## DISPOSAL OF ELECTRICAL AND ELECTRONIC EQUIPMENT

(Applies within the EU, and for other European countries with segregated waste collection systems.)

This device contains electrical and/or electronic components and should therefore not be disposed of in general household waste. Instead it should be disposed of at a recycling collection point provided by the local authority. This costs you nothing. If the device itself contains replaceable (rechargeable) batteries, these must be removed first and, if necessary, also be disposed of in line with the relevant regulations.

Further information on this issue is available from your local administration, your local waste collection company, or in the store where you purchased this device.

### Camera production date

The production date of your camera can be found on the stickers in the Warranty Card or on the packaging.

The date convention is: Year /Month /Day



## DESIGNATION OF PARTS

Figures in the front and rear cover pages

### Front view

1. Lens release button
2. Eyelet for carrying strap
3. Focus button
4. Rangefinder viewing window
5. Brightness sensor<sup>1</sup>
6. Viewfinder viewing window
7. Self-timer LED
8. Frame selector
9. Bottom cover locking point

### Top view

10. Microphone
11. Fixed ring with
  - a. Index for distance setting
  - b. Depth of field scale
  - c. Red index button for changing lenses
12. Aperture setting ring
13. Index point for aperture setting
14. Lens hood
15. Focusing ring with
  - a. Grip
16. Main switch with detent positions for
  - **OFF** (camera turned off)
  - **S** (single pictures)
  - **C** (serial exposures)
  -  (self-timer)
17. Shutter release button with
  - a. Thread for cable release
18. Video shutter button
19. Shutter speed dial with detent positions for
  - **A** Aperture priority
  - Shutter speeds  $1/4000$  - 8s (inc. intermediate values)
  - **B** (Long-time exposure)
  -  Flash sync speed ( $1/180$ s)
20. Accessory shoe

<sup>1</sup> Leica M lenses with viewfinder attachment cover the brightness sensor. Information about functions with these and other lenses can be found under "Displays / In the viewfinder", p. 232, and "Leica M lenses", p. 143.



**Rear view**

21. **SET** button
  - For calling up the picture parameters menu
  - For calling up sub-menus in the menu system
  - For applying settings/functions selected in sub-menus
22. **MENU** button for calling up and exiting the main menu and sub-menus
23. **ISO** button for calling up the sensitivity setting
24. **DELETE** button for selecting the delete function
25. **PLAY** button
  - For activating (continuous) review mode
  - To return to full-screen display
26. **LV** button for turning live view mode on and off
27. Viewfinder window
28. Socket for external electronic viewfinder / microphone adapter<sup>1</sup> (cover removed)
29. Brightness sensor for monitor
30. Thumbwheel
  - For navigating in the menus
  - For setting the selected menu options / functions
  - For setting an exposure compensation value
  - For enlarging/reducing pictures viewed
  - For scrolling through the picture memory
31. Direction pad
  - For navigating in the menus
  - For setting the selected menu options / functions
  - For scrolling through the picture memory

32. **INFO** button
  - For displaying picture settings/data
  - For displaying picture data during picture review
  - For applying settings
33. Speaker
34. LED for indicating picture mode / recording data
35. Monitor

**Bottom view**

(with bottom cover attached)

36. Locking toggle for bottom cover
37. Tripod thread A ¼, DIN 4503 (¼")
38. Bottom cover

(with bottom cover removed)

39. Socket for multifunction M hand grip<sup>1</sup>
40. Memory card slot
41. Battery compartment
42. Battery locking slider

<sup>1</sup> Available as an accessory, see p. 220

## QUICK-START GUIDE

**You will need the following items:**

- Camera
- Battery
- Memory card (not supplied)
- Charger and mains cable

## PREPARATIONS

1. Charge the battery (see p. 137)
2. Insert the battery (see p. 140)
3. Insert the memory card (see p. 142)
4. Turn on the camera (see p. 146)
5. Set the menu language (see p. 154)
6. Set the date and time (see p. 154)
7. Format the memory card, if necessary (see p. 212)

## TAKING PHOTOGRAPHS

8. Attach the lens (see p. 145)
9. Set the shutter speed dial to **A** (see p. 149)
10. Set the subject focus (see p. 170)
11. Turn on the camera (see p. 146)
12. Turn on exposure metering (see p. 147)
13. Correct the exposure, if necessary (see p. 182)
14. Release the shutter (see p. 147)

### Note:

For details of how to shoot videos, see p. 190.

## VIEWING PICTURES

The camera is preset to display the last picture automatically for a short time (see p. 198).

You can turn on review mode (for an unlimited period) at any time using the **PLAY** button (see p. 198).

To view different pictures, press left or right on the direction pad (see p. 204).

To enlarge the pictures, turn the thumbwheel to the right (see p. 205).

## DELETING PICTURES

Press the **DELETE** button and follow the instructions in the monitor (see p. 206).

## PREPARATIONS

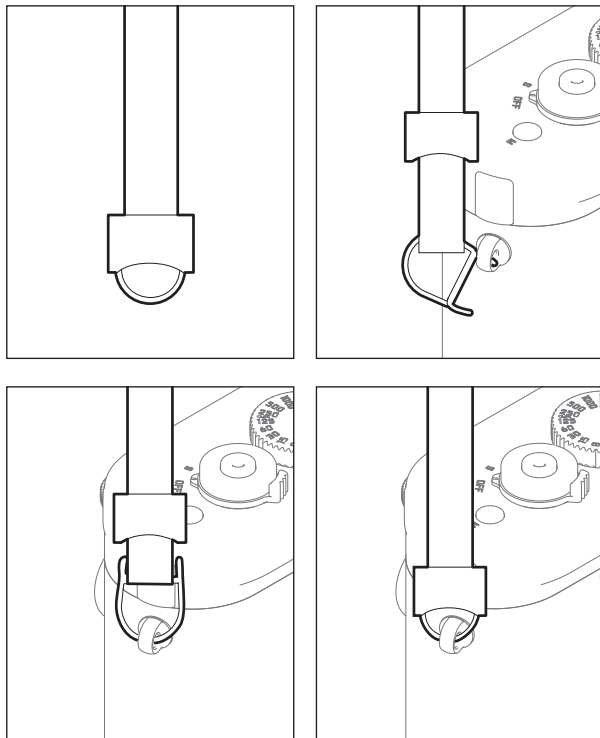

## CHARGING THE BATTERY

The camera is powered by a lithium ion battery.

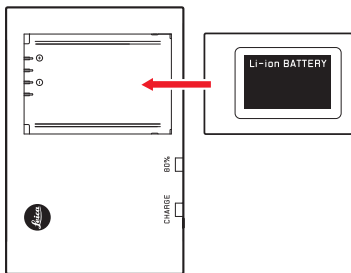

- The green LED marked **CHARGE** starts flashing to confirm that charging is in progress. As soon as the battery has charged to at least  $\frac{4}{5}$  of its capacity, the yellow LED marked **80%** also lights up. When the battery is fully charged, the green LED also changes from flashing to continuously lit.

### Note:

The **80%** LED lights up after around 2 hours due to the charging characteristics.

The charger should be disconnected from the mains when charging is complete. There is therefore no risk of overcharging.

**Caution:**

- Only the battery type specified and described in these instructions (Order No. 14 499), or battery types specified and described by Leica Camera AG, may be used in this camera.
  - These batteries may only be used in the units for which they are designed and may only be charged exactly as described below.
  - Using this battery contrary to the instructions and using non-specified battery types can result in an explosion under certain circumstances.
  - The batteries must not be exposed to heat or sunlight for prolonged periods, or to humidity or moisture. Likewise, the batteries must not be placed in a microwave oven or a high pressure container as this results in a risk of fire or explosion.
  - A safety valve in the battery guarantees that any excess pressure caused by improper handling is discharged safely.
  - Only the charger specified and described in these instructions (order no. 14 494) is to be used. The use of other chargers not approved by Leica Camera AG can cause damage to the batteries and, in extreme cases, can cause serious or life-threatening injuries.
- The charger supplied should be used exclusively for charging this battery type. Do not attempt to use it for other purposes.
  - The car charging cable supplied must never be connected while the charger is connected to the mains.
  - Ensure that the mains outlet used for charging is freely accessible.
  - The battery and charger must not be opened. Repairs may only be carried out by authorized workshops.

**Notes:**

- The battery should be charged before the camera is used for the first time.
- The battery must have a temperature of 10°-30°C / 50°-86°F to be charged (otherwise the charger will not turn on, or will turn off again).
- Lithium ion batteries can be charged at any time, regardless of their current charge level. If a battery is only partly discharged when charging starts, it is charged to full capacity faster.
- The batteries warm up during the charging process. This is normal and not a malfunction.
- If the two LEDs on the charger flash rapidly (> 2Hz) after starting charging, this indicates a charging error (e.g. maximum charging time exceeded, voltages or temperatures outside the permitted ranges, or short circuit). In this case, disconnect the charger from the mains and remove the battery. Ensure that the above temperature conditions are met and then restart the charging process. If the problem persists, please contact your dealer, the Leica office in your country or Leica Camera AG.
- A new battery only reaches its full capacity after it has been fully charged and – by use in the camera – discharged again 2 or 3 times. This discharge procedure should be repeated every 25 cycles. To ensure a maximum service life of the battery, it should not be exposed to constant extremes of temperature (e.g. in a parked car in the summer or winter).
- Even when used in optimum conditions, every battery has a limited service life. After several hundred charging cycles, this becomes noticeable as the operating times become significantly shorter.
- The battery should be replaced after a maximum of four years, as its performance deteriorates and reliable operation can no longer be guaranteed, particularly in cold conditions.
- Defective batteries should be disposed of according to the respective instructions (see p. 225).
- The replaceable battery provides power to a back-up battery which is built into the camera. This back-up battery retains the set date and time for up to 2 months. If this back-up battery becomes discharged it must be recharged by inserting the replaceable main battery. Once the replaceable battery has been inserted, the full capacity of the back-up battery is recovered after about a few days. This process does not require the camera to be turned on.

## REPLACING THE BATTERY AND MEMORY CARD

Set the main switch to **OFF**.

### Important:

Do not open the bottom cover or remove the memory card or battery while the red LED at the bottom right next to the monitor is flashing, indicating picture recording and/or data saving to the card. Otherwise the unsaved (or not completely saved) picture data may be lost.

### Removing the bottom cover

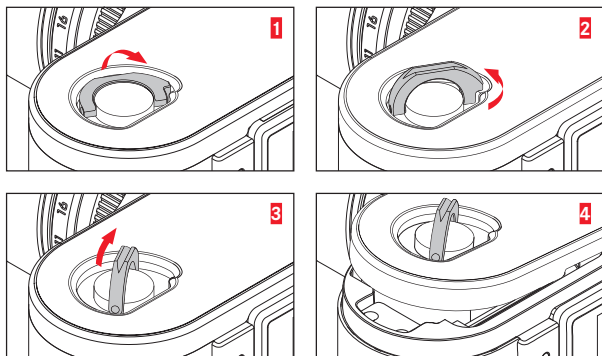

### Inserting the battery

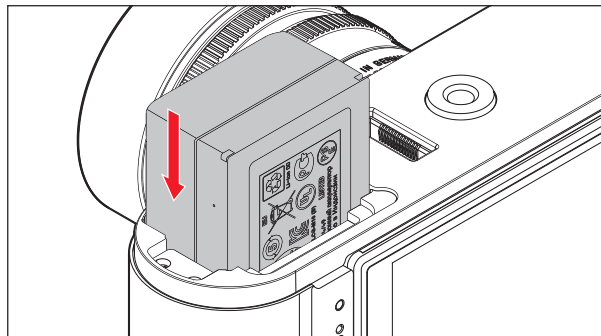

### Removing the battery

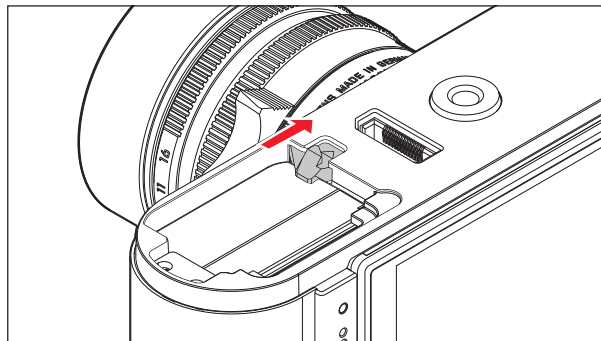



### Charge level displays

In picture mode, the battery charge level is displayed in the monitor by pressing the **INFO** button.

#### Notes:

- Remove the battery if you will not be using the camera for a long period of time.
- A maximum of 2 months after the capacity of a battery left in the camera is exhausted (see also the last note under “Charging the battery”, p. 137), the date and time need to be re-entered.
- As the battery capacity deteriorates or if using an older battery, depending on the function being used warning messages and displays may appear and functions may be restricted or blocked.

### Compatible memory cards

The camera saves the pictures on an SD (secure digital), SDHC (high capacity), or SDXC (eXtended capacity) card. SD/SDHC/SDXC memory cards are available from various suppliers and with different capacities and read/write speeds. Particularly those with high capacities and read/write speeds allow data to be recorded and retrieved very quickly. The cards have a write protection switch, which can be used to prevent unintentional storage and deletion of pictures. This switch takes the form of a slider on the non-beveled side of the card; in the lower position, marked LOCK, the data on the card is protected.

#### Note:

Do not touch the memory card contacts.

## Inserting the memory card

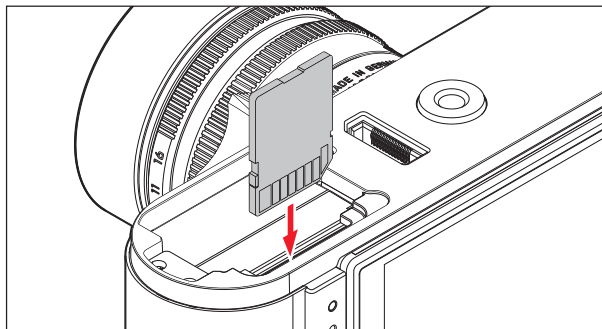

## Removing the memory card

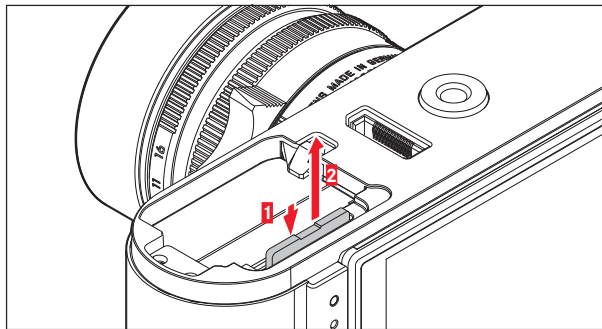

## Notes:

- The range of SD/SDHC/SDXC cards is too large for Leica Camera AG to be able to completely test all available types for compatibility and quality. Although using other card types is not likely to damage the camera or the card, some "no name" cards do not comply with the SD/SDHC/SDXC standards, and Leica Camera AG is unable to provide any guarantee that they will function correctly.
- Video recordings in particular require a high write speed.
- If the memory card cannot be inserted, check that it is aligned correctly.
- If you remove the bottom cover or the memory card when the camera is turned on, the monitor displays the corresponding warning messages instead of the normal displays:
  - **Attention Bottom cover removed**
  - **Attention No card inserted.**
- As electromagnetic fields, electrostatic charges, and defects on the camera or the card can lead to damage or loss of the data on the memory card, we recommend that you also transfer the data to a computer and save it there (see p. 213).
- For the same reason, it is recommended that the card is always stored in an antistatic cover.

## LEICA M LENSES

Generally, most Leica M lenses can be used. Details on the small number of exceptions and restrictions can be found in the following notes.

They can be used regardless of the lens features, and whether it does or does not have 6-bit coding in the bayonet.

Even without this additional feature, i.e. when using Leica M lenses without identification, the camera will deliver excellent pictures in most situations.

To ensure optimum picture quality in these situations, we recommend entering the lens type (see p. 158).

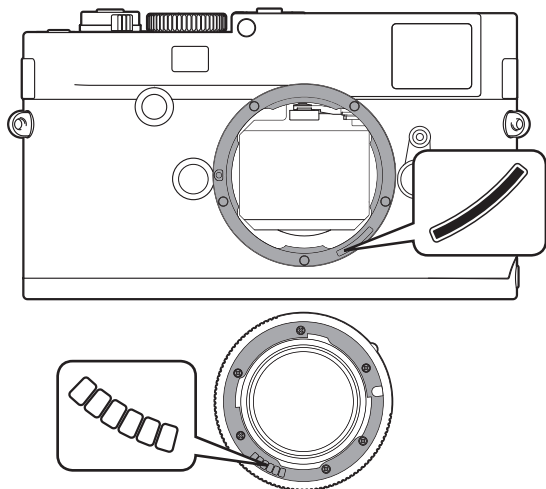

### Important:

- The following models cannot be used:
  - Hologon 15mm f/8
  - Summicron 50mm f/2 with close up attachment.
  - Elmar 90mm f/4 with retractable tube (manufactured from 1954-1968)
  - Some versions of the Summilux-M 1.4/35mm (not aspherical, manufactured from 1961-1995, Made in Canada) cannot be mounted to the camera or will not focus to infinity. The Leica Customer Care department can modify these lenses so that they can be used on the camera.
  
- The following can be used, but risks damaging the camera or the lens:
  - Lenses with retractable tube can only be used with the tube extended, i.e. their tube must never be retracted into the camera. This is not the case with the current Macro-Elmar-M 1:4/90mm, as its tube does not protrude into the camera body even when retracted. It can therefore be used without any restrictions.

- The following can be used with restrictions  
Despite the high precision of the rangefinder on the camera, exact focusing with 135mm lenses with an open aperture cannot be guaranteed due to the very low depth of field. Therefore, stopping down by at least 2 stops is recommended. By contrast, live view mode (see p. 168) and the various setting facilities allow unrestricted use of this lens.
- The following can be used, but are excluded from **Classic** exposure metering (see p. 174)
  - Super-Angulon-M 21mm f/4
  - Super-Angulon-M 21mm f/3.4
  - Elmarit-M 28mm f/2.8 with serial nos. before 2 314 921.

**Notes:**

- The Leica Customer Care department can upgrade many Leica M lenses with 6-bit coding. (Address, see p. 248).
- In addition to Leica M lenses with and without coding, Leica R lenses can also be used in combination with the Leica M adapter R available as an accessory (see p. 218).

## Attaching the lens

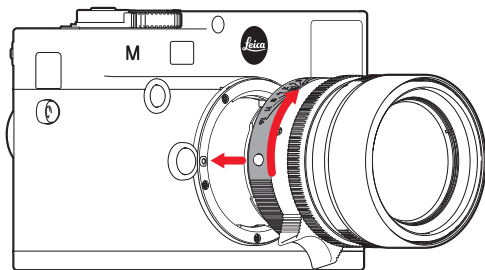

1. Turn off the camera.
2. Hold the lens at the fixed ring.
3. Align the red index button on the lens with the release button on the camera housing.
4. In this position, insert the lens.
5. Turn the lens slightly to the right, and you will hear and feel it click into place.

## Detaching the lens

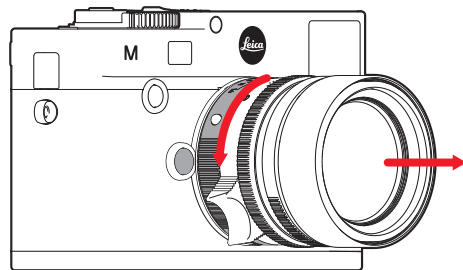

1. Turn off the camera.
2. Hold the lens at the fixed ring.
3. Press down the release button on the camera body.
4. Turn the lens to the left until its red index button is aligned with the release button.
5. Remove the lens.

### Notes:

- Generally: To protect the Leica M against ingress of dust etc. into the interior of the camera, it is important always to have a lens or a cover attached to the camera body.
- For the same reason, when changing lenses work quickly and in an environment that is as dust-free as possible.
- Camera or lens rear caps should not be stored in your pants pocket as they attract dust that can get into the camera when they are attached.

## THE MOST IMPORTANT SETTINGS / CONTROLS

### TURNING THE CAMERA ON AND OFF

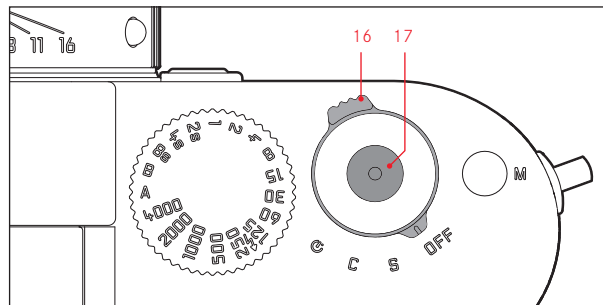

The camera is turned on and off using the main switch. This is below the shutter release button and is a lever with four detent positions:

- a. **OFF** – Camera turned off
- b. **S** – Single picture  
Pressing the shutter release takes a single picture regardless of how long it is held down for.

- c. **C** – Continuous series  
A series of pictures are taken for as long as the shutter release is held down and the capacity of the memory card used and the internal buffer memory is sufficient. At least 16 pictures are taken in rapid succession, subsequent pictures with a reduced frequency.
- d. **☺** – Self-timer  
Pressing the shutter release starts the set delay time (see p. 192), then the picture is taken.

### TURNING ON

After turning on, i.e. after setting one of the three functions **S**, **C** or **☺**, the LED lights up briefly and the displays in the viewfinder appear (see p. 232).

#### Note:

After turning on, the camera is ready to use after approx. 1s.

### TURNING OFF

Even if the main switch is not set to **OFF**, the camera is automatically turned off if an automatic power off time has been set in the menu (**Auto Power Off**, see p. 156), and none of the controls are used in this time.

**Note:**

If the camera is out of use for an extended period or is stored in a case, always turn it off at the main switch. This prevents any power consumption, including that which continues to occur in standby mode after the exposure meter is turned off automatically and the display is extinguished. This also prevents pictures from being taken accidentally.

**SHUTTER RELEASE BUTTON**

The shutter release button has two pressure points:

1. Pressing down to the 1st pressure point
  - activates exposure metering and the viewfinder display
  - saves the metered exposure value in aperture priority mode, i.e. the shutter speed determined by the camera (for more details, refer to the “Metering memory lock” section on p. 177)
  - restarts a self-timer delay time that is already in progress (see p. 192)

If the shutter button is kept at this pressure point, the displays remain visible, or if the camera had previously been set to review mode, it switches back into picture mode. If the camera had previously been in stand-by mode, it will be reactivated and the displays switched on. If you release the shutter button, the metering system and the displays remain activated for around a further 12s (for more details, refer to the sections on p. 174).

**Note:**

The shutter button remains blocked

- if the internal buffer memory is (temporarily) full, e.g. after a series of  $\geq 16$  pictures, or
- if the memory card inserted and the internal buffer memory are (temporarily) full, or
- if the battery has exceeded its performance limits (capacity, temperature, age)

2. Pressing the shutter release button all the way down takes the picture or starts a preselected self-timer delay time. The data is then transferred to the memory card.

The shutter release button has a standard thread for a cable release.

**Notes:**

- If review mode (see p. 198) or menu control (see p. 150) had been activated, pressing the shutter button causes the camera to switch immediately into picture mode.
- To avoid camera shake, the shutter button should be pressed gently, not jerkily, until the shutter is released with a soft click.
- The shutter button can be pressed to take one or more individual pictures while a video recording is in progress. Details of video recordings and the video shutter button (18) can be found on p. 190.

### Serial exposures

You can not only take single pictures - by setting the main switch to **S** [single] - but also series of pictures, by setting the main switch to **C** [continuous], e.g. to capture sequences of movement in several stages.

Apart from operation of the shutter button, series of pictures are taken in the same way as single pictures: A series of pictures is taken for as long as you hold down the shutter button (provided that the memory card has sufficient capacity). If you only press it briefly, the camera continues to take single pictures.

A maximum of around 3 frames per second can be produced. At least the first 16 of these are taken in rapid succession, after which the image frequency is reduced slightly.

### Notes:

- The specified picture frequency and the maximum possible number of pictures in a series relate to a default setting - **ISO 320** and **JPEG fine** format. The frequency and number may be lower when using different settings or depending on the memory card used.
- Regardless of how many pictures have been taken in a series, both review modes (see p. 198) initially show the last picture in the series or the last picture in the series saved on the currently active card, if not all of the pictures in the series have been transferred from the internal buffer memory to the relevant card yet.



## SHUTTER SPEED DIAL

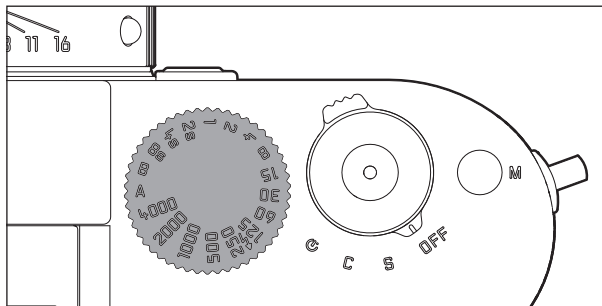

The exposure modes are selected using the shutter speed dial,

- aperture priority mode by setting the **A** position marked red (see p. 176),
- manual mode by selecting a shutter speed of  $1/4000$ s to 8s (intermediate values in  $1/2$  step positions are also available);
- the shortest possible sync speed of  $1/180$ s for normal flash mode, marked with the , and
- **B** for long exposures (see p. 182).

The Leica M shutter speed dial has no stop, i.e. it can be turned in either direction from any position. It detents at all marked positions and at the intermediate values. Values between the detent positions cannot be used. More details on setting the correct exposure can be found in the sections from p. 174.

## MENU CONTROL

Many settings for the camera are controlled using two separate menus (see p. 240/241).

The split into two menus and the grouping in the main menu allows what experience has shown to be the most frequently used options to be called up and set quickly and easily.

When the camera is turned on, an overview of the relevant settings and step-by-step instructions for setting these options can be viewed in the monitor.

Settings are made in the same way in both menus, the differences are only in calling up and exiting them.

## MAIN MENU

The main menu is made up of 33 options. It is divided into 3 function groups:

- **CAMERA** (basic camera settings – menu page 1)
- **IMAGE** (picture settings – menu page 2)
- **SETUP** (supplementary functions – menu pages 3-5)

## PICTURE PARAMETERS MENU

The picture parameters menu is made up of 8 options. In addition to basic picture settings, it contains two options relating to exposure metering and control and one that can be used to create and call up user profiles.

## Setting the menu functions

- The main menu is called up using the **MENU** button, and the picture parameters menu using the **SET** button.
  - The first = **CAMERA** page containing the first 6 options then appears in the main menu, and all options in the picture parameters menu.

The active option when a menu is selected is always the option that was last used.

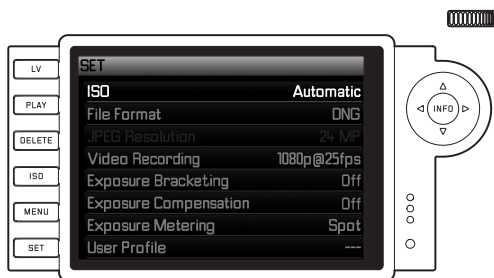
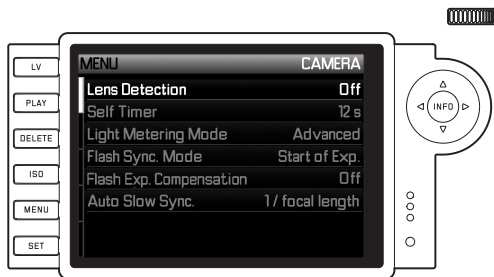

## Note:

The picture parameters menu is only accessible when the camera is in picture mode.

2. You can select the relevant option either using the thumbwheel (turn right = down in menu, turn left = up in menu) or the direction pad (press up or down).

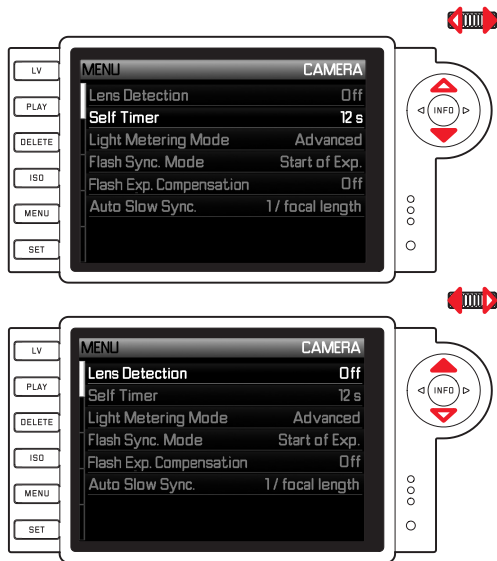

### Notes:

- Using the thumbwheel is normally not only more convenient but also significantly faster.
  - Some options, such as **GPS** and **Format SD card**, as well as some sub-menu options, can only be called up in certain situations. Further explanations can be found in the relevant sections.
  - This is indicated by the lettering in the corresponding lines being grayed out.
3. You can select the relevant sub-menus with both the **SET** button and the **INFO** button or by pressing right on the direction pad.
- The displays in the header change: The associated function group is shown in black on the left (**CAMERA**, **IMAGE** or **SETUP** in the main menu, always **SET** in the picture parameters menu), with the selected menu option in white on the right.
- The sub-menus usually consist of different numbers of function options, which can be directly selected in the next step.
- In some cases, there is also a scale for setting values, or the sub-menus consist of secondary entries for which function options can be selected in turn.

4. Select the relevant function option / value, either using the thumbwheel or by pressing the corresponding direction on the direction pad, i.e.

- up/down to change lines or to select options
- left/right for settings within a line or on a scale

For sub-entries with selectable options, it is also possible to change line using the **INFO** button.

- The displays in the header change again: The sub-entry is specified in black on the left, with the selected option in white on the right.

#### Note:

Options such as **Date/Time** and the **Exposure bracketing** functions require additional settings. The corresponding explanations, as well as further details about the other menu functions, can be found in the relevant sections.

5. Save your setting using the **SET** or **INFO** button.
- The monitor screen reverts to its initial condition. The new function option set is then shown on the right of the corresponding menu line.

#### Note:

You can exit the menus and sub-menus at any time - without applying the settings made - by pressing the following buttons:

	<b>Shutter button/ PLAY Video shutter release</b>	<b>MENU</b>
<b>Main menu</b>	Camera switches to picture mode	Camera switches to review mode One step back (e.g. to previous menu level)
<b>Picture parameters menu</b>	Camera switches to picture mode	Camera switches to review mode One step back (e.g. to previous menu level), or return to main menu

## PRESETS

### BASIC CAMERA SETTINGS

#### MENU LANGUAGE

The camera is set to English by default. German, French, Italian, Spanish, Russian, Japanese, Korean and traditional or simplified Chinese can all be selected as alternative menu languages.

#### Setting the function

1. In the main camera menu, (see p. 150/240) **Language** (page 5, section **SETUP**), and
2. select the desired language in the sub-menu.
  - Apart from a few exceptions (button names, short designations), all linguistic information changes.

#### DATE AND TIME

These entries can be made by selecting **Date/Time**.

#### Setting the functions

1. In the main camera menu, (see p. 150/240) select **Date/Time** (page 5, section **SETUP**), and
2. call up the sub-menu. This is made up of the three options **Auto time/time zone**, **Date** and **Time**.

#### Automatic time display controlled by GPS

This option is only available if the multifunction M hand grip is attached (available as accessory, see p. 220 ff.).

3. Select **Auto time/time one**.
  - A further sub-menu appears containing the three options **Auto time via GPS**, (only available if the **GPS** function is activated in the menu, see p. 193), **Time zone** and **Summer time**.
4. In this sub-menu, select **Auto time via GPS**, and
5. set the preferred option (**ON/OFF**).

If this function is activated, the time set on the camera is updated continuously based on GPS signals received.

**For correct time display anywhere in the world:**

6. In the same sub-menu select **Time zone**, and
7. select the relevant zone / your current location.
  - The current set difference from Greenwich Mean Time is shown on the right of the line, with large cities and the current time in the relevant time zones below.

**Entering the correct time in countries with seasonal time changes:**

8. In the same sub-menu select **Summer time**, and
9. set the preferred option (**ON/OFF**).

**Note:**

**Time zone** and **Summer time** are only available when the **Auto time** via **GPS** function is deactivated.

**DATE**

There are 3 options available for the sequence of the date.

3. In the **Date / Time** sub-menu, select **Date**. It contains the 2 options **Format** and **Setting**.
4. Select **Format**.
5. In the **Format** sub-menu, select which of the 3 possible conventions you wish to use **Day/Month/Year**, **Month/Day/Year**, and **Year/Month/Day**.
6. Save your setting.
  - The **Date** sub-menu appears again.
7. Select **Setting**.
  - A further sub-menu appears, with columns for the year and day figures and for the month names. The currently active, i.e. editable, column is indicated by red underlining, with the heading in white and the figures and names that can be set in red.

Use the thumbwheel or direction pad to set the numbers / months, and the **SET** button or **INFO** button or direction pad to switch between the columns.
8. After making the setting, confirm all 3 headings and save them.

## TIME

The time can either be shown in 24-hour or 12-hour format. Both the display format and the actual figures are set using the **Time** option, essentially in the same way as described for the **Date** option in the previous section.

### Note:

Even if no battery is inserted or the battery is flat, an integrated back-up battery retains the date and time setting for around 2 months. After this time the date and time must be set again as described above.

## AUTOMATIC POWER OFF

This function turns the camera off automatically after a preset time.

### Setting the function

1. In the main camera menu, (see p. 150/240) select **Auto Power Off** (page 5, section **SETUP**).
2. Now select the desired time.

### Note:

Even if the camera is in standby mode, i.e. the displays have gone out after 30s or the activated **Auto Power Off** function has turned it off, it can be reactivated at any time by pressing the shutter release button.



## SIGNAL TONES

You can decide whether you want warning messages that appear in the monitor and the self-timer countdown to be accompanied by an acoustic signal – two volumes are available – or whether operation of the camera should be largely silent.

### Note:

The factory default setting for signal tones is **OFF**.

### Setting the functions

1. In the main camera menu, (see p. 150/240) select **ACOUSTIC SIGNAL** (page 5, section **SETUP**).
2. You can now select **OFF**, **Low volume** or **High volume**.

## BASIC PICTURE SETTINGS

### LENS TYPE DETECTION

The 6-bit coding in the bayonet fastening of current Leica M lenses allows the camera to identify the type of lens attached using the sensor in the bayonet socket.

- Among other things, this information is used to optimize the picture data. Thus edge darkening which can be noticeable with wide-angle lenses and large apertures can be compensated in the corresponding picture data.
- Flash exposure and reflector control also use the lens data (see "Compatible flash units", p. 184).
- In addition, the information provided by this 6-bit coding is written to the EXIF data for the picture. When displaying extended image data, the lens focal length is also shown (see p. 234).

#### Setting the function

1. In the main camera menu, (see p. 150/240) select **Lens Detection** (page 1, section **CAMERA**), and
2. select the desired option in the sub-menu:
  - **OFF**, or
  - **Automatic**, if a coded lens is attached, or
  - **Manual**, if a non-coded lens is attached.

#### Note:

When using lenses without 6-bit coding, the lens type identification function must be deactivated to prevent malfunctions, or the lens type used must be entered manually (see p. 158).

#### Manual lens type / focal length entry

The camera is unable to recognize previous Leica M lenses as they have no identification. However, this "identification" can be carried out in the menu.

The same applies to Leica R lenses, which can be used on the camera with a Leica R adapter M (for further details, refer to the adapter's instructions).

3. Select the lens you are using from the list in the **Manual** sub-menu.
  - The monitor shows a list of lenses, which also includes the relevant item numbers to ensure clear identification. The camera detects whether an M lens is attached, or a Leica R lens using the adapter. The list contains either only M or only R lenses accordingly.

#### Notes:

- On many lenses, the item number is engraved on the reverse side of the depth of field scale.
- The list contains lenses that were available without coding (prior to around June 2006). Lenses introduced more recently are only available with coding and therefore cannot be selected manually.
- When using the Leica Tri-Elmar-M 16-18-21mm f/4 ASPH., the set focal length is not transferred to the camera and thus is not included in the EXIF data for pictures. If required, you can enter the relevant focal length manually.

- By contrast, the Leica Tri-Elmar-M 1:4/28-35-50mm ASPH. features mechanical transfer of the set focal length to the camera, necessary to display the appropriate bright line frame in the viewfinder. It is detected by the camera electronics and used for focal length specific compensation. However, only one item number - 11 625 - is listed in the menu for reasons of space. Of course, the other two versions - 11 890 and 11 894 - can be used and the settings made in the menu also apply to them.

### VIGNETTING (SHADING) CORRECTION

In photography, "vignetting" means shadowing towards the edge of the picture. All lenses exhibit this effect to a different extent, particularly with an open aperture and high light intensity. If the camera recognizes the lens type attached, it can compensate this effect to a certain extent.

If vignetting is desired as a style element, this correction function can be deactivated.

#### Setting the function

1. In the main camera menu (see p. 150/240) (page 2, section **IMAGE**), select **Shading correction** and
2. select the desired option in the relevant sub-menu (**ON** / **OFF**).

### FILE FORMAT

The picture data is recorded either

- a. in the JPEG file format **JPEG fine**, or
- b. in the **DNG** file format, either compressed or uncompressed, or
- c. using combinations of one of the **JPEG fine** format and the set DNG format, i.e. two files are always generated per picture.

On the one hand this allows you to take account of the intended usage and the available memory card capacity, and on the other hand provides the security and flexibility essential for deciding on the usage later.

#### Setting the function

#### Selecting the format / format combination

1. In the picture parameters menu (see p. 150/240) select **File format**, and
2. select the desired format format combination in the relevant sub-menu.

## Selecting the DNG compression

1. In the main camera menu (see p. 150/240) select **DNG compression** (page 2, section **IMAGE**), and
2. select the desired option in the relevant sub-menu (**ON** [=compressed] / **OFF** [=uncompressed]).

### Notes:

- The standardized DNG (Digital Negative) format is used for storage of completely unprocessed raw picture data.
- The available compression for DNG format
  - is lossless, i.e. it does not cause any deterioration in quality
  - retains all of the post-editing performed on the image data
  - allows faster saving
  - takes up less memory space.
- If simultaneous storage of picture data as DNG and JPEG is selected, the existing resolution setting is used for the JPEG format, i.e. the resolutions of the two files can be quite different.
- The remaining number of pictures shown in the monitor does not necessarily change after every picture. This depends on the subject; with JPEG files very fine structures result in higher quantities of data, homogeneous surfaces in lower quantities.

## RESOLUTION:

The picture data can be recorded in JPEG format at four different resolutions. This allows you to adjust the setting precisely to the intended use or to the available memory card capacity. At the highest resolution (which also means the largest data volume), which you should select for optimum quality for large prints, a card can hold significantly fewer pictures than at the lowest resolution.

### Setting the function

1. In the picture parameters menu (see p. 150/240) select **JPEG resolution**, and
2. select the desired resolution in the sub-menu.

### Note:

In DNG format, the resolution is 24MP, i.e. regardless of any different setting made for JPEG format.

## ISO SENSITIVITY

The ISO setting covers a range of ISO 320 – 12500 in  $\frac{1}{3}$  ISO increments, and thus enables you to adapt the shutter speed/aperture values to the relevant situation as required. In addition there is the setting **Push 25000** that corresponds to a sensitivity of ISO 25000.

As well as the fixed settings, the camera also features the **Auto**<sup>1</sup> function, in which the camera automatically adjusts the sensitivity to the ambient brightness and the shutter speed/aperture settings. In conjunction with aperture priority mode (see p. 176) this extends the range for automatic exposure control. A manual setting provides more flexibility for using the desired shutter speed/aperture combination.

However, when using the function it is also possible to specify priorities, for example for compositional reasons.

### Note:

Particularly at high ISO values and when editing pictures, noise as well as vertical and horizontal stripes may become visible, especially in large, uniformly bright areas of the subject.

<sup>1</sup> The function is not available when using flash units.

## Setting the function

### With the ISO button

1. Press the **ISO** button.
  - The corresponding sub-menu appears in the monitor.
2. While holding down the **ISO** button, use the thumbwheel to select the desired sensitivity or the automatic setting.

### Note:

When you release the **ISO** button, the sub-menu remains visible for around 2s. However, the set value is applied immediately.

### Using the menu

1. In the picture parameters menu (see p. 150/240), select **ISO**, and
2. use the thumbwheel or press up/down on the direction pad to set the desired sensitivity or select the automatic setting.
3. confirm your setting with the **INFO** or **SET** button.

### To set the sensitivity automatically

3. In the 2nd step, select **Auto**.
  - The previously grayed-out (unavailable) sub-menu options are now enabled.

**Note:**

By factory default, the **Maximum ISO** function is limited to **ISO 12500**.

**To restrict the automatic setting range**

- In this sub-menu, select **Maximum AUTO ISO** and/or **Maximum exposure time**.
- In the **Maximum AUTO ISO** sub-menu, select the highest sensitivity to be used, and hence the range within which the automatic setting is to operate, or in the **Maximum exposure time** sub-menu set either one of the three focal length-specific settings - **1/focal length**, **1/2xfocal length**, **1/4xfocal length**<sup>2</sup> if you wish to leave it to the camera to ensure wobble-proof shutter speeds, or the slowest shutter speed that you wish to set ( $1/2\text{s}$  -  $1/500\text{s}$  in whole steps). In the focal length-specific settings, the camera only switches to a higher sensitivity if the shutter speed would fall below the threshold due to lower brightness, e.g. with a 50mm lens at slower speeds than  $1/60\text{s}$  at **1/focal length**, or  $1/125\text{s}$  at **1/2xfocal length**, or  $1/250\text{s}$  at **1/4xfocal length**.
- Confirm your setting with the **INFO** or **SET** button.

**Specifying AUTO ISO mode in manual exposure setting**

- In this sub-menu select **AUTO ISO in M mode**, and then **On** or **Previous ISO**.
- If you select **On**, automatic control is active (where appropriate within the limit you specified in the **Maximum AUTO ISO** sub-menu item). If you select **Previous ISO**, the last manually set sensitivity will be used.
- Confirm your setting with the **INFO** or **SET** button.

**Note:**

The following rule applies when using automatic bracketing (see p. 180):

The sensitivity automatically determined by the camera for the uncorrected picture is also used for all other pictures in a series, i.e. this ISO value is not changed during a series. This may mean that the slowest shutter speed specified under **Maximum exposure time** is exceeded.

<sup>2</sup> This function requires the use of coded lenses or setting of the lens type used in the menu (see p. 158).

The functions and settings described in the next two sections refer exclusively to pictures in the JPEG format. If one of the two DNG formats is specified, these settings have no effect, as in this case the picture data is always saved in its original form.

## IMAGE PROPERTIES / CONTRAST, SHARPNESS

In digital photography, key picture properties can be changed very easily. While photographic software – after recording and transfer to a computer – provides great scope for doing this, the camera itself allows you to influence two of the most important picture properties even before taking the picture:

- The contrast, i.e. the difference between light and dark areas, determines whether a picture has a more “matt” or “glossy” effect. As a consequence, the contrast can be influenced by increasing or reducing this difference, i.e. by lighter reproduction of light sections of the image and darker reproduction of dark sections.
- Sharp reproduction – at least of the main subject – using the correct distance setting is a prerequisite for a successfully picture. In turn, the impression of sharpness of a picture is to a great extent determined by the sharpness of the edges, i.e. by how small the transition area between light and dark is at the edges in the picture. The impression of sharpness can thus be changed by expanding or reducing these areas.

All three picture properties can be adjusted – independently – to five different levels using the menu, so that you can set the optimum values for any situation, i.e. the prevailing lighting conditions.

## Setting the functions

1. In the main menu (see p. 150/240) select **Sharpness** or **Contrast** (section **IMAGE**), and
2. select the desired setting in the sub-menu.

## TONING

Toning has always been a popular stylistic device in black-and-white photography. A slight "coloration" of the black-and-white picture gives it a different "character". A brownish tint can give the picture an "antique" effect, a bluish tint a cold mood. With the Leica M Monochrom you have the choice between three such tints, each in two intensities.

## Setting the function

1. In the main menu (see p. 150/240) select **Toning**,
2. then select the type of toning – **Hue** or **Strength** in the respective sub-menu, and
3. in the respective sub-menus select the desired settings, i.e. for **Hue** the color (**Sepia**, **Blue** or **Selenium**), or for **Strength** the color saturation, (**OFF**, **Weak** or **Strong**).

## BRIGHT-LINE VIEW AND RANGEFINDER

This camera's bright-line view- and rangefinder is not only a very high-quality, large, brilliant and bright viewfinder, it is also a highly accurate rangefinder coupled to the lens. All lenses with focal lengths from 16 to 135mm connect automatically when mounted on the camera. The viewfinder has a magnification factor of 0.68x. When using lenses with focal lengths of 28 (Elmarit from serial number 2 411 001), 35, 50, 75, 90 and 135mm, the relevant LED-lit frame is automatically illuminated in the combinations 28+90mm, 35+135mm, and 50+75mm. They can be lit in red or white. This enables it to be seen perfectly in all lighting conditions and for all subjects.

### Selecting the bright-line frame color

1. In the main camera menu, (see p. 150/240) select **Frameline Color** (page 3, **SETUP** section), and
2. select the desired color in the sub-menu.

The size of the bright-line frame corresponds to a sensor size of 23.9 x 35.8mm at a range setting of 2m. It is linked to the range setting to ensure that the parallax - the offset between the lens and the viewfinder axis - is automatically compensated. At a range of below 2m the sensor detects slightly less than shown by the inner edges of the bright-line frame, and slightly more at longer ranges (see adjacent diagram). These slight variations, which are hardly ever critical in practice, are due to the operating principle.



Bright-line frames on a viewfinder camera must be matched to the angle of the relevant lens focal lengths. However, the nominal angles of view change slightly when focusing due to the changing extension, i.e. the distance between the optical system and the sensor plane. If the set distance is less than infinity (and the extension correspondingly greater), the actual angle of view is smaller - the lens captures less of the subject. In addition, the differences in the angle of view tend to be greater at longer focal lengths, as a result of the greater extension.

In the middle of the viewfinder image is the square range metering field, which is brighter than the surrounding image field. If the exposure meter is turned on, the exposure meter LEDs and the flash symbol LED appear at the lower edge of the viewfinder image. For more details about setting the distance and exposure metering, as well as flash mode, refer to the relevant sections on p. 170/174/184.



All pictures and bright-line frame positions relative to 50mm focal length

<b>A</b>	Bright-line frame
<b>B</b>	Actual image field
Set to 0.7m:	The sensor detects approx. one frame width less.
Set to 2m:	The sensor detects exactly the image field shown by the inner edges of the bright-line frame.
Set to infinity:	The sensor detects approx. 1 or 4 (vertical or horizontal) frame width(s) more.

## FRAME SELECTOR

The frame selector extends the possibilities of this built-in universal viewfinder: This allows you at any time to activate the bright line frames which do not belong to the lens currently being used. You can then see immediately if, for image composition reasons, it would be better to photograph the relevant subject using a different focal length.

If the lever is rotated outwards, i.e. away from the lens, the frames for 35 and 135mm focal length are shown.

If the lever is rotated to the vertical, centered position, the image frames for 50 and 75mm focal length are shown. If the lever is rotated inward, i.e. toward the lens, the frames for 28 and 90mm focal length are shown.

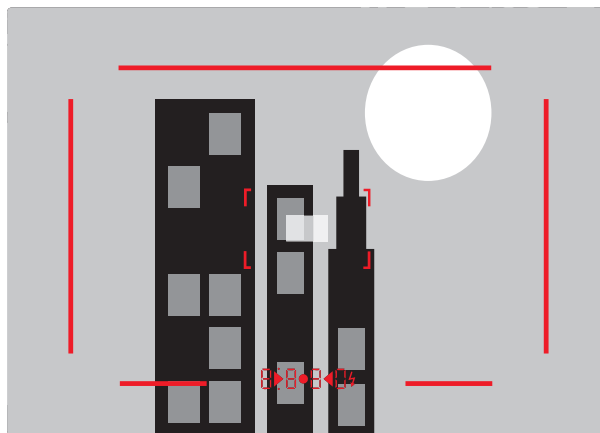

35mm + 135mm

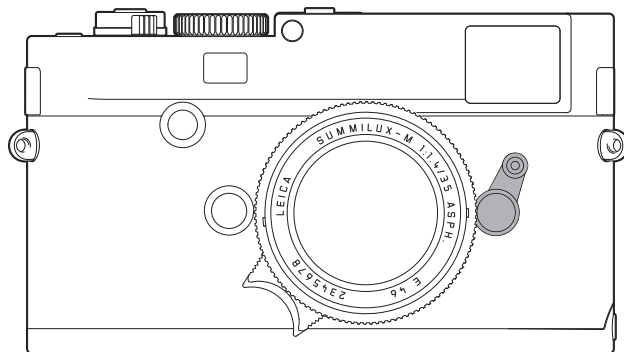

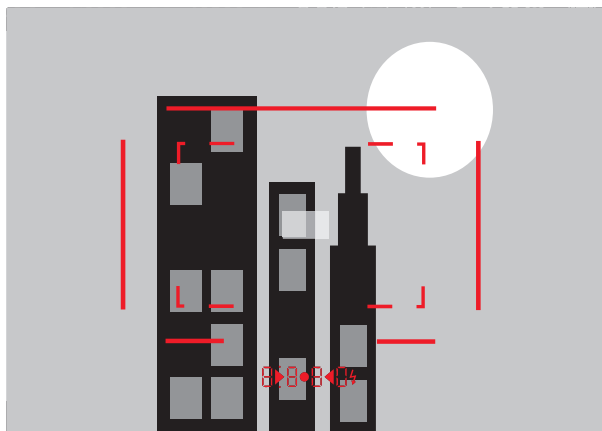

50mm + 75mm

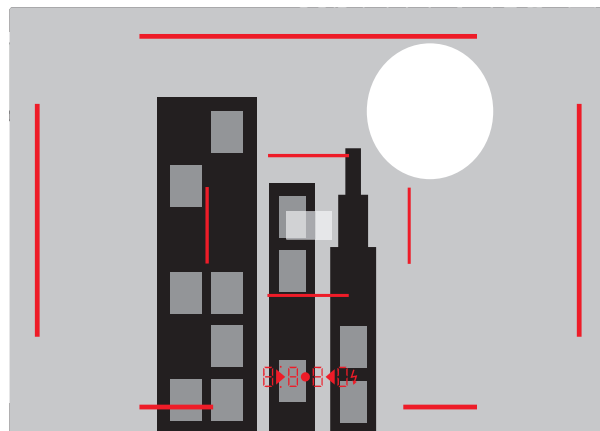

28mm + 90mm

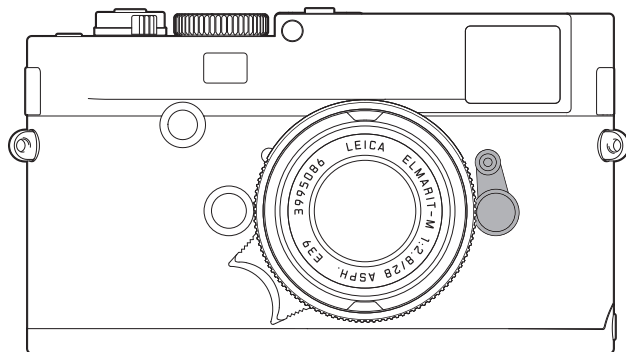
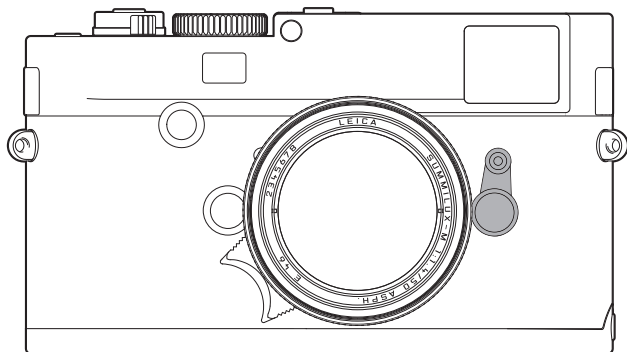

## MONITOR

The camera has a large 3" liquid-crystal monitor protected by a glass cover of extremely hard, particularly scratch-resistant sapphire glass. In picture mode with the live view function activated, it shows the image detected by the sensor through the attached lens. In review mode, it is used to view the pictures taken on the memory card. In both cases, it shows the entire image field, along with the selected data and information (see p. 234).

### Setting the brightness

The brightness of the monitor image can be set using the menu. You can choose from automatic control, i.e. depending on the ambient brightness, and five manual levels, so that you can adapt it perfectly to the relevant situation:

1. In the main camera menu, (see p. 150/240) select **Monitor brightness** (page 3, section **SETUP**), and
2. select the automatic setting or the desired level in the sub-menu.

### Notes:

- With the exception of the menu system (see p. 150), you can (optionally) view all of the displays described in these instructions in exactly the same way in an attached electronic viewfinder (such as the Leica EVF2, available as an accessory, see p. 218).
- The **EVF brightness** option (main menu, page 3, section **SETUP**, see p. 150/240) can be used to set the brightness of this kind of viewfinder in exactly the same way as described above.

## LIVE VIEW MODE

Live view mode on this camera enables you to view the subject in the monitor when taking a picture, with a precise indication of how the attached lens will capture it. It is also a prerequisite for using particular focusing methods (see p. 172) and exposure metering methods (see p. 174). Use the **LV** button to turn Live View mode on and off. To make sure Live View mode is not activated unintentionally, you can also disable the **LV** button.

### Turning the LV button function ON/OFF

1. In the main camera menu, (see p. 150/240) select **Exposure metering** (page 1, section **CAMERA**), and
2. in the sub-menu select **Classic/LV deactivated**.

### Brightness of the Live View monitor image

Two options are available. In the factory default setting "Shutter release half pressed" the brightness depends on the handling of the shutter release button.

1. Shutter release button was pressed briefly to switch on the metering system and then released again.

The subject is displayed

- Irrespective of the exposure mode used (aperture priority / manual setting), and
- Irrespective of the preset shutter speed/aperture settings in the brightness corresponding to an optimum exposure setting.

This applies as long as

- the subject brightness and the set exposure do not result in exceptionally low or high brightness values, and
- the measured exposure time is not too long.

- The shutter release button is pressed to the first pressure point: The brightness of the monitor image corresponds to that of the respective exposure setting. This allows you to assess the effect the exposure setting will have on the image before shooting.

Conversely, as soon as you press the shutter release to the first pressure point the brightness of the monitor image matches the exposure setting. This allows you to assess the effect the exposure setting will have on the image before shooting. The second option, **Continuous**, is effective only with a manual exposure setting. It always shows the effects of your shutter speed and aperture settings by a correspondingly brighter or darker monitor image.

### Setting the function

- In the main camera menu, (see p. 150/240) select **Exposure simulation** (page 4, section **SETUP**),
- call up the sub-menu, and
- there select **Shutter release half pressed** for the first mode, or **Continuous** for the second mode.

By default, the live view monitor image contains some fundamental information in a header. You can use the **INFO** button to select two other views with more information (see p. 234). In the first, you can additionally view frames for the aspect ratios 1:1, 3:4, 6:7 or 16:9. This can make image composition for subsequent detailing much easier.

The frames are selected in sequence by moving the direction pad up or down.

### Horizon

If this function is enabled, a third view featuring a spirit level is available. Thanks to integrated sensors and this view, the camera is able to display its orientation. This enables you to align the camera precisely in the longitudinal and transverse axis to capture critical subjects, e.g. architecture pictures.

### Turning the spirit level view on/off

- In the main camera menu, (see p. 150/240) select **Horizon** (page 4/section **SETUP**),
- call up the sub-menu, and
- there select **ON** or **OFF**.
  - In the fourth Live View image, a vertical scale and a horizontal bar appear in the monitor. Variations from the relevant zero positions are indicated graphically – by red markings – and the horizontal alignment in the longitudinal and transverse axis by a central green marking.

### Notes:

- Live view mode is based on the image captured by the sensor. To use it, the shutter must be open and it is closed and re-cocked when the function is canceled. Of course, this is audible and results in a slight delay in the shutter release.
- Frequent use of the Live View mode results in increased power consumption.
- Alternating current causes fluctuations in the brightness of many light sources which are invisible to the eye. Owing to the sensitivity and scan rate of image sensors, this can result in flickering of the monitor image or lines in videos (not photos). The effect can be eliminated from the shot by choosing a slower shutter speed.

## DISTANCE SETTING

Various tools are available for setting the range, depending on whether you are using the camera's internal optical viewfinder and/or Live View mode (see p. 168).

### Notes:

- The electronic displays are based on the image captured by the sensor. To use it, the shutter must be open and it is closed and re-cocked when the function is canceled. Of course, this is audible and may result in a slight delay in the shutter release, and also results in increased power consumption if used frequently.
- Due to the different sensitivities and function conditions, there may be differences between the optimum settings and those displayed.

## With the optical rangefinder

Due to its large effective metering basis, the rangefinder on this camera is very precise. The benefits of this are particularly noticeable when using wide-angle lenses with their relatively high depth of field.

<b>Mechanical metering basis</b> (Distance between the optical axes of the viewfinder window and the rangefinder viewing window)	<b>x viewfinder zoom</b>	<b>= Effective metering basis</b>
69.25mm	x 0.68	= approx. 47.1mm

The rangefinder metering field is visible as a bright, sharply defined rectangle in the center of the viewfinder. The focus can be set using either the superimposed image or split image method:

### Superimposed image method (double image)

In a portrait, for example, aim the metering field at the eye and turn the distance setting ring on the lens until the contours in the metering field are brought into line. Then choose the subject detail.

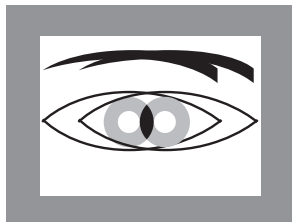

Out of focus

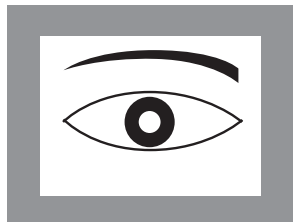

In focus

### Split image method

When taking photographs of architecture, for example, aim the range finder metering field at the vertical edge or another clearly defined vertical line and turn the distance setting ring on the lens until the contours of the edge or line can be seen at the limits of the metering field with no misalignment. Then choose the subject detail.



Out of focus

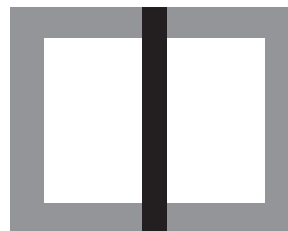

In focus

**DISTANCE SETTING** (continued)**Note:**

The following two functions are also available with Leica R lenses, i.e. not only with Leica M lenses with 6-bit coding and Leica M lenses selected using the menu.

**With the monitor image in Live View mode**

In Live View mode (see p. 168) you can set the sharpness using the monitor image, as it displays the subject with exactly the same sharpness as is produced by the lens depending on the range and aperture setting.

**Procedure**

1. Turn on Live View mode using the **LV** button.
2. Use the focusing ring on the lens to focus on the desired subject details.

To make the setting easier and increase the accuracy of the setting, you can enlarge a central detail of the monitor image. You can call up this function in two ways.

**For occasional use:**

1. Press the focus button.
  - The monitor image shows
    - the enlarged detail
    - the thumbwheel symbol with the possible enlargement / reduction directions
    - the current zoom factor.
 You can change the zoom factor using the thumbwheel - either 5x or 10x.
2. Use the focusing ring on the lens to focus on the desired subject details.

**For continuous use:**

1. In the main camera menu, (see p. 150/240) select **Focus Aid** (page 3, section **SETUP**), and
2. in the sub-menu select **Automatic**.
  - As soon as you turn the focusing ring on the lens, the enlarged detail described above appears. You can return to the normal - i.e. unzoomed - view at any time by tapping the shutter release.

You can change the enlargement as required using the thumbwheel or call up the unzoomed 1x view of the entire monitor area.



## With indication of in focus subject details in the monitor image

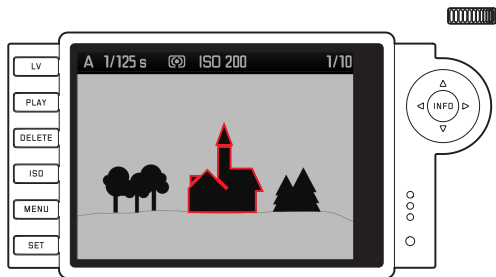

In Live View mode you can mark subject details with optimum focus in the monitor image, which makes them very easy to identify. The three available colors permit adaptation to the ambient lighting.

## Procedure

1. In the main camera menu, (see p. 150/240) select **Focus Peaking** (page 3, section **SETUP**), and
2. in the sub-menu select **Red**, **Blue** or **Green**, or **Off** if you do not want to use the function.
3. Turn on Live View mode using the **LV** button.
4. Select your trimming.
5. Press the focus button or turn the focusing ring on the lens so that the desired subject details are marked.
  - All subject details that are in focus at the set range are indicated by outlines in the selected color.

## Important:

This function is based on the subject contrast, i.e. light/dark differences. Therefore, subject details that are not completely in focus but have a high contrast may also be marked.

## TURNING THE EXPOSURE METER ON / OFF

The exposure meter is turned on by tapping the shutter release button, provided the camera is turned on at the main switch and the shutter speed dial is not set to **B**.

The displays in the viewfinder or monitor light up continuously to indicate that the exposure meter is ready:

- in aperture priority mode the LED display of the shutter speed,
- and in manual mode one of the two triangular LEDs in the viewfinder lights up, either individually or in conjunction with the center circular LED, while the light balance is displayed in the monitor.

If you let go of the shutter release button without activating the shutter, the exposure meter remains turned on for around 30s more, and the relevant LED(s) remain lit for the same time. If the shutter speed dial is set to **B**, the exposure meter is disabled.

### Notes:

- In aperture priority mode, if correct exposure cannot be achieved using the available shutter speeds, the shutter speed display gives a warning by flashing (only in the viewfinder, for more details, refer to the "Aperture priority mode" section on p. 176).
- If the exposure meter reading is below the metering range in very low lighting conditions and in manual mode, the left hand triangular LED in the viewfinder flashes as a warning, or the left-hand bar of the light balance flashes in the monitor. In aperture priority mode, the shutter speed is still displayed. If the required shutter speed falls below the slowest possible setting of 60s, this display also flashes in the viewfinder.

- If the camera is out of use for an extended period or is stored in a case, always turn it off at the main switch. This also prevents pictures from being taken accidentally.

## EXPOSURE METERING METHODS

Two metering methods are available on this camera:

- Strongly center-weighted metering in **Classic** mode. This method takes account of the entire image field, although the parts of the subject situated in the center have more influence on the exposure value calculation than the areas at the margins.
- The light reflected by a bright shutter diaphragm blade in the first shutter curtain is captured by a photo diode and measured.
- A choice of spot, center weighted and multi-field metering in **Advanced** mode or using Live View mode (see p. 168). Metering with the picture sensor is a prerequisite for this.

## Required preliminary setting if not using Live View mode

1. In the main camera menu, (see p. 150/240) select **Exposure metering** (page 1, section **CAMERA**), and
2. in the sub-menu select
  - **Classic** shutter metering, for the conventional metering method described above, or
  - **Advanced** sensor metering if you want to be able to choose between the three metering methods described below.

### Notes:

- In Live View mode, the three metering methods are always available, i.e. even if **Classic** is set.
- With the third sub-menu option - **Classic/ LV deactivated** - the function of the **LV** button can be disabled.

## Selecting the metering method

1. In the picture parameters menu (see p. 150/240) select **Exposure Metering** and
  2. select the desired metering method in the sub-menu:
    - **Spot** Only a small area in the center of the image is captured and evaluated. This area is indicated by the rectangle in the center of the monitor image.
    - **Center-weighted** Similar to the **Classic**- centering weighting described above.
    - **Multi-field** This metering method is based on detection of multiple metered values. The values are used in an algorithm to calculate an exposure value appropriate to the situation, resulting in correct reproduction of the assumed main subject.
- The set metering method is specified in the monitor in live view and video mode, and in the extended (**INFO**) display (see p. 234).

### Notes:

- For the metering methods based on the image sensor, the shutter must be open and it is then closed and re-cocked when the function is canceled. Of course, this is audible and may result in a slight delay in the shutter release.
- Frequent use of the Live View mode results in increased power consumption.

The appropriate shutter speed for correct exposure, or the variation from a correct exposure setting, are specified or determined using displays in the viewfinder or monitor (see following sections).

## METERING MEMORY MODES

The camera provides two exposure modes: Aperture priority mode and manual mode. Depending on the subject, situation and your individual preferences, you can thus choose between

- the familiar “semi automatic” operation, or
- setting a fixed shutter speed and aperture.

## APERTURE PRIORITY

If the shutter speed dial is in the **A** position, the electronics within the camera generates the exposure time automatically and continuously in the range  $1/4000$ s to 60s, in accordance with the film speed setting, the metered brightness and the manually selected aperture. The calculated shutter speed is displayed in half steps to provide a better overview.

For shutter speeds slower than 2s the remaining exposure time is counted down and displayed in seconds after the shutter release. The actually generated and continuously controlled exposure time can however vary from the half step value displayed: For example, if the display shows **1/6** (the closest value) before releasing the shutter, but the calculated exposure time is longer, the countdown after releasing the shutter may actually start from **1/5**.

Under extreme lighting conditions, based on all the parameters the exposure meter may generate a shutter speed that is outside the working range, i.e. brightness values that would require shorter exposures than  $1/4000$ s or longer than 60s. In such cases the specified minimum or maximum shutter speed is nevertheless used, and these values flash in the viewfinder as a warning.

## Notes:

- As described in connection with the ISO setting on p. 161, a certain amount of noise becomes apparent when using higher sensitivities, and particularly with uniform dark surfaces. To reduce this annoying phenomenon, after pictures with slow shutter speeds and high ISO values the camera automatically takes a second “black picture” (taken with the shutter closed). The noise present in this parallel picture is then digitally “subtracted” from the data for the real picture. As a result, the message **Noise reduction** appears for **12s**<sup>1</sup> in the monitor. This doubling of the “exposure” time can be significant at longer exposure times, and must be allowed for. During this time the camera should not be turned off.
- If the **B** function is selected in conjunction with the auto shutter release (see p. 182, the shutter release button does not need to be kept pressed; the shutter will remain open until the shutter release button is pressed a second time (this is then equivalent to a **T** function)).

<sup>1</sup> Time data is an example

## EXPOSURE LOCK

For compositional reasons, the most important part of the subject is often not in the center of the picture, and as a result such important parts of the subject may be excessively light or dark. Center-weighted metering and spot metering record predominantly or exclusively an area in the center of the image are calibrated to an average gray scale value.

Subjects and situations of this type can be overcome very easily even in aperture priority mode, using metering memory lock.

### Notes:

- Metering memory lock should not be used in conjunction with multi-field metering, as in such cases selective recording of a single subject detail is not possible.
- In conjunction with exposure lock (by pressing the shutter release down to the first pressure point), Live View also provides an exposure simulation feature (see p. 168).

## Using the function

1. Aim at the important subject detail (with the metering field for spot metering) or alternatively at another detail with average brightness.
2. Pressing the shutter release down to the first pressure point activates metering and storage. As long as the pressure point is held, a small red dot appears in the viewfinder at the top in the digits line for confirmation, and the exposure time no longer changes even if the lighting conditions are different. A dot appears between the ISO and exposure compensation values in the monitor.
3. Keeping the shutter release pressed, move the camera to capture the final trimming,
4. The shutter can then be released using the exposure originally determined.

Changing the aperture setting after using exposure lock has no effect on the shutter speed, and will lead to an incorrect exposure. Exposure lock is canceled when you remove your finger from the shutter release pressure point.

## EXPOSURE COMPENSATION

Exposure meters are calibrated to an average gray scale value (18% reflection), which corresponds to the brightness of a normal, i.e. average photographic subject. If the actual subject detail does not match this assumption, an appropriate exposure compensation can be performed.

Particularly when taking several pictures in succession, for instance if for any reason a series of pictures is taken deliberately using slight under or overexposure, exposure compensation is a very useful function: In contrast to exposure lock, once set it remains effective until it is reset. Exposure compensation can be set in the range  $\pm 3\text{EV}$  in  $1/3\text{EV}$  steps (EV: Exposure Value).

## Entering and canceling an exposure compensation

Two options are available for setting an exposure compensation: You can make the setting using the menu or - provided the function is enabled - with the thumbwheel.

Setting using the menu is recommended if, for example, you know before taking a series of pictures that you want your subjects to be slightly under or overexposed. The exceptionally fast option using the thumbwheel is ideal when unexpected situations occur and enables you to track your subject in the viewfinder without interruptions.

## A. Using the menu

1. In the picture parameters menu (see p. 150/240), select **Exposure Compensation**.
  - A scale appears in the monitor instead of a sub-menu, with an EV value indicated in red and a white triangle to indicate the relevant setting. If they are at a value of **0**, this means that the function is deactivated.
2. Set the desired value.
  - In the initial menu list, a set compensation is indicated by **EV+\_X<sup>1</sup>**.

## B. Using the thumbwheel

There are two options for settings using the thumbwheel. They offer you the choice between somewhat faster working and a setting which is safer to protect against unintentional adjustment.

1. In the picture parameters menu (see p. 150/240) select **Exposure Compensation**, and
2. move the direction pad up or down to select the **Direct adjustment** option.
3. Select **On** if you want to work faster using only the thumbwheel, or **Off** if you want the safer option.

If you selected **On**:

4. Use the thumbwheel to set the desired compensation value.

If you selected **Off**:

4. Hold the focus button pressed down and use the thumbwheel to set the desired compensation value.
  - The compensation value in the viewfinder changes accordingly, for example **1.0-/0.3**, while the monitor (in Live View mode) displays both the compensation value and the resulting changed shutter speed.

### Important:

An exposure compensation set on the camera only influences metering of the available light, i.e. not flash light (for more information about flash photography, refer to the sections starting on p. 184).

Regardless of how the set compensation was originally entered:

- It remains effective until it is manually reset to **0**, regardless of whether the camera has been turned off and back on in the meantime.
- It can be reset using either the menu or the thumbwheel.
- It is displayed in the form of EV values in the picture parameters menu and in the monitor in Live View mode, and in the form of changed shutter speeds and a flashing dot at the bottom in the viewfinder, or for about 0.5s when the display is activated by tapping the shutter release down to the first pressure point.

<sup>1</sup> Example, either plus or minus, "±X" stands for the relevant value

## AUTOMATIC BRACKETING

Many attractive subjects are very rich in contrast, i.e. they have both very light and very dark areas. The effect can be quite different, depending on which sections you base your exposure on. In such cases, the automatic bracketing function in aperture priority mode on the Leica M Monochrom enables you to produce several alternatives with graduated exposure, i.e. using different shutter speeds. You can then select the most suitable picture for further use, or use appropriate software to create a picture with an exceptionally high contrast range (HDR).

The following are available:

- 4 graduations: **0.5EV**, **1EV**, **2EV** and **3EV**
- 2 numbers of pictures: 3 or 5

## Setting the function

1. In the picture parameters menu (see p. 150/240), select **Bracketing**.
  - A sub-menu containing the three options **Frames**, **Aperture stops**, and **Automatic** is displayed in the monitor, with a scale below.
 

If an exposure compensation is set at the same time, this is indicated by a corresponding value below the scale.
2. When using **Frames**, select whether you want to use bracketing and the number of pictures to use.
  - White triangles appear above the selected intervals marked in red in the scale. They specify the relevant exposure values.
3. Confirm the setting.
  - The setting for **Aperture stops** is marked as ready for editing.
4. Select the desired function graduation.
  - The marked intervals and the triangles change positions according to the selected graduation.

## Notes:

- If the bracketing exceeds the range of  $\pm 3EV$  - due to the combination of the number of pictures and graduation - the scale division changes from  $\pm 3EV$  to  $\pm 6EV$ . The intervals and triangles displayed adjust accordingly.
- Note that both settings have to be made and confirmed, otherwise the function will not be active.
- A set exposure series remains active until it is switched off again in the menu. This applies regardless of whether the camera has been turned off and back on in the meantime.



5. Confirm the setting.
  - The setting for **Automatic** is marked as ready for editing.
6. Select the desired setting: **ON** to start bracketing automatically when the shutter is released once, **OFF** to release the shutter individually for each picture.
7. Confirm the setting.
  - A set exposure series is indicated in the initial menu list by **XEV/X<sup>1</sup>**.
8. All pictures are produced by pressing the shutter release button once or several times (see p. 146).

**Notes:**

- The following rule applies when using automatic bracketing: The sensitivity automatically determined by the camera for the uncorrected picture is also used for all other pictures in a series, i.e. this ISO value is not changed during a series. This may mean that the slowest shutter speed specified under **Set maximum exposure time** is exceeded.
- Depending on the initial shutter speed, the working range for automatic bracketing may be limited.
- Regardless of this, the specified numbers of pictures are always taken, which may mean that several pictures in a series have the same exposure.
- Automatic bracketing is also possible when using flash. It is implemented without regard to the state of charge of the flash unit, meaning the series may contain shots both with and without flash.
- The function remains active until it is deactivated again in the **Pictures** sub-menu, i.e. even after the camera has been turned off and back on. If it is not deactivated, another series of pictures is taken each time the shutter release button is pressed.

<sup>1</sup> Example, first "X" stands for the graduation, the second for the number of pictures

## MANUAL EXPOSURE SETTING

If the exposure setting is performed entirely manually, the shutter speed dial must be clicked to one of the engraved shutter speeds or to one of the intermediate values.

Then:

1. Turn on the exposure meter, and
2. turn the shutter speed dial and /or the aperture setting ring on the lens – in each case in the direction indicated by the triangular LED that is lit up – until only the circular LED is lit up.

As well as the direction of rotation of the shutter speed dial and aperture setting ring necessary for correct exposure, the three LEDs in the light balance also indicate underexposure, overexposure and correct exposure in the following way:

- ▶ Underexposure by at least one aperture stop; turning to the right is required
- ▶● Underexposure by  $1/2$  aperture stop; turning to the right is required
- Correct exposure
- ◀ Overexposure by  $1/2$  aperture stop; turning to the left is required
- ◀ Overexposure by at least one aperture stop; turning to the left is required

### Note:

For shutter speeds slower than 2s the remaining exposure time is counted down and displayed in seconds after the shutter release.

## B SETTING / T FUNCTION

With the **B** setting, the shutter remains open for as long as the shutter release button is held down (up to a maximum of 60s; depending on the ISO setting).

In conjunction with the self-timer, a T function is also available: If **B** is set and the self-timer is activated by tapping the shutter release button (see also p. 192), the shutter opens automatically after the selected delay time. It then remains open until you press the shutter release button a second time – you do not need to hold the button down. This enables you to largely prevent any blurring, even with long exposures, by pressing the shutter release button.

In both cases, the exposure meter is disabled; after the shutter is released however the digital display in the viewfinder counts the elapsed exposure time in seconds, for guidance.

### Fixed settings for slow shutter speeds

1. Hold down the focus button.
  - The shutter speed sub-menu appears in the monitor. Available shutter speeds - depending on the ISO sensitivity – are marked in white, those that are unavailable in gray.
2. Use the thumbwheel or the direction pad (left/right) to select the desired shutter speed.
  - The sub-menu is displayed for a further 2s after the focus button is released.
3. Release the shutter.

**Notes:**

- Long exposure times can be associated with very heavy picture noise.
- To reduce this annoying phenomenon, following exposures with slower shutter speeds (below approx.  $1/30$ s, differing depending on other menu settings) the Leica M Monochrom automatically takes a second "black picture" (with the shutter closed). The noise present in this parallel picture is then digitally "subtracted" from the data for the real picture.

This doubling of the "exposure" time can be significant at longer exposure times, and must be allowed for. During this time the camera should not be turned off.

- At shutter speeds of more than 2s, the message **Noise reduction 12s<sup>1</sup>** appears in the monitor.

**VALUES ABOVE AND BELOW THE METERING RANGE**

If the exposure meter reading is below its working range in very low lighting conditions and in manual mode, the left hand triangular LED (▶) flashes as a warning in the viewfinder, while the right hand LED (◀) does the same if there is too much light. In aperture priority mode, the shutter speed is still displayed. If the required shutter speed is more than the slowest possible 60s or less than the fastest possible of  $1/4000$ s, these displays also flash. As the exposure is metered with the working aperture, this situation can come about by stopping down the lens. Even if you are below the metering range, the exposure meter remains on for around 30s after you let go of the shutter release button. If the lighting conditions improve in this time (e.g. through a change in the subject detail or opening of the aperture), the LED display changes from flashing to continuously lit, indicating that the meter is ready.

<sup>1</sup> Time data is an example

## FLASH MODE

The camera determines the necessary flash power by firing one or more ranging flashes, fractions of a second before taking the actual picture. Immediately after this, at the start of exposure, the main flash is fired.

All factors that influence the exposure (such as picture filter and changes to the aperture setting) are automatically taken into account.

## COMPATIBLE FLASH UNITS

The following flash units can be used with the camera. They allow TTL flash metering and, depending on the configuration, a varying number of the functions described in these instructions.

- With its compact dimensions and design that matches the camera, the Leica SF 26 system flash unit is the perfect solution. It is also extremely easy to operate.
- Leica system flash units
- Flash units that satisfy the technical requirements for a System 3000 System Camera Adaption (SCA), are equipped with the SCA-3502-M5<sup>1</sup> adapter and allow guide number control.

Other commercially available flash units with standard flash foot and positive center contact, and fired by the center contact (X contact) can also be used. We recommend the use of modern thyristor-controlled electronic flash units.

## ATTACHING THE FLASH UNIT

Before attaching a flash unit to the accessory shoe on the camera,

- the cover that protects the accessory shoe and the socket when not in use, must be detached to the rear, and
- the camera and flash unit must be turned off.

When attaching a flash unit, you should ensure that the foot of the flash unit is fully inserted into the accessory shoe and the clamping nut is tightened to prevent it accidentally falling out. This is particularly important for flash units with additional control and signal contacts, because if the position in the accessory shoe changes the necessary contacts can be broken, leading to malfunctions.

### Notes:

- This also applies when using a flash unit with SCA adapter set (see p. 220).
- Make sure the accessory shoe cover is always attached when no accessories are in use (such as a flash unit, an external viewfinder or microphone). It will protect the socket 28 for a time against water incursion.

## FLASH MODE

Fully automatic flash mode, i.e. controlled by the camera, is available on the camera with the system-compatible flash units listed in the previous section, and in aperture priority **A** and manual exposure modes.

In addition, automatic illumination control is operational in all three exposure modes. This means that in order to ensure a balanced relationship between flash and other lighting at all times, the flash power is reduced by up to  $1\frac{2}{3}$ EV as ambient brightness increases. However, if the ambient brightness plus even the shortest possible

flash sync time of  $\frac{1}{180}$ s would cause overexposure, a non-HSS compatible flash unit will not be fired in aperture priority mode. In such cases the shutter speed is governed by the ambient brightness and is shown in the viewfinder.

In aperture priority mode **A** and with manual setting, the camera also allows the use of creative flash techniques such as synchronization of flash firing with the 2nd shutter curtain rather than the 1st, as is usual, and flash with slower shutter speeds than the sync speed of  $\frac{1}{180}$ s. These functions are set on the camera using the menu (for more details, refer to the relevant sections below). In addition, the camera transfers the set sensitivity to the flash unit. Provided it has received such information and the aperture manually set on the lens is also input to the flash unit, this allows the flash unit to automatically adjust its range values accordingly. The sensitivity setting cannot be influenced from the flash unit as it is transferred from the camera.

**Notes:**

- Studio flash systems may have a very long burning time. Therefore, when using them it may be useful to select a slower shutter speed than  $1/180\text{s}$ .
- The same applies to radio controlled flash triggers for "un-chained flash", as the radio transmission can cause a delay.
- The following sections describe only those settings and functions that are available when using this camera with system-compatible flash units.
- An exposure compensation set on the camera (see p. 178) only influences the measurement of available light! In order to be able to make a correction of the flash exposure at the same time during photography with flash, this must be set separately.
- More details of flash use, in particular for other flash units not specially adapted to this camera and for different flash modes, can be found in the relevant instructions.

**Settings for camera-controlled automatic flash mode**

After the flash unit in use has been turned on and set to guide number control mode (e.g. TTL or GNC), the following actions on the camera are necessary:

1. Before taking each flash picture the exposure metering is first performed by gently pressing the shutter release, so that the display in the viewfinder shows the shutter speed or switches to the light balance. If this stage is missed out by fully depressing the shutter release in one quick movement, the flash unit will not fire even if required.
2. The shutter speed dial must be set to **A**, to the flash sync speed ( $1/180\text{s}$ ), or to a slower shutter speed (including **B**). With HSS-compatible Leica system flash units, faster shutter speeds can be set than the sync speed.

**Note:**

If the exposure metering in aperture priority mode results in faster shutter speeds than the sync speed, an HSS flash (see p. 66) is automatically triggered instead of a "normal" photo flash.

3. The desired aperture, or the aperture required for the relevant distance to the subject, must be set.

**Note:**



If the automatically controlled or manually set shutter speed is faster than  $1/180\text{s}$ , the flash is not fired unless the flash unit is HSS-compatible (see p. 188).

**Flash exposure displays in the viewfinder with system-compatible flash units**



A flash-shaped LED appears in the viewfinder as confirmation and to display the various operating conditions. This LED appears together with the displays for exposure metering for the ambient light level, described in the relevant sections.

### In automatic flash mode

(flash unit set to GNC or TTL)

-  does not appear despite the flash unit being switched on and ready for use:  
A faster shutter speed than  $1/180\text{s}$  is set manually on the camera and the connected flash unit is not HSS-compatible. In such cases the camera will not fire the flash unit even though it is switched on and ready for use.
-  flashes slowly (at 2Hz) before the picture is taken:  
The flash unit is not yet ready to use
-  is lit up before the picture is taken:  
The flash unit is ready for use

### When the flash unit is set to camera control (A) or manual mode (M)

-  does not appear despite the flash unit being switched on and ready for use:  
An exposure time shorter than  $1/180\text{s}$  has been set manually on the camera. In such cases the camera will not fire the flash unit even though it is switched on and ready for use.
-  flashes slowly (at 2Hz) before the picture is taken:  
The flash unit is not yet ready for use.
-  is lit up before the picture is taken:  
The flash unit is ready for use.

### Flash exposure compensation

This function can be used to selectively reduce or strengthen the flash exposure regardless of the exposure of the available light, e.g. in a picture taken outside in the evening, to lighten the face of a person in the foreground while retaining the lighting atmosphere.

#### Setting the function

1. In the picture parameters menu (see p. 150/240), select **Flash Exposure Compensation**.
  - A scale appears in the monitor instead of a sub-menu, with an EV value indicated in red and a white triangle to indicate the relevant setting. If they are at a value of 0, this means that the function is deactivated.
2. Set the desired value.
  - In the initial menu list, a set compensation is indicated by **EV±X1**.

This menu function is only available when a system-compatible flash unit is used that does not have such a setting possibility itself, such as the Leica SF 26.

#### Notes:

- Flash exposure compensation changes the range of the flash unit.
- A set compensation remains active even after any number of pictures and even when the camera is switched off, or until it is reset to  $\pm 0$  (= middle of scale).

## LINEAR FLASH MODE (HIGH SPEED SYNCHRONIZATION)

Fully automatic, i.e. camera controlled, linear flash operation is available with this camera when using correspondingly equipped Leica system flash units, with all shutter speeds and in aperture priority and manual exposure modes. The camera activates it automatically if the selected or calculated shutter speed is faster than the sync speed of  $1/180$ s. If the flash unit is set correctly, this change does not require the photographer to do anything else.

### Important:

The range for HSS flash is significantly lower than for TTL flash.

## SELECTING THE SYNC SPEED / THE SYNC SPEED RANGE

Reproduction of the available light is determined by the shutter speed and the aperture. A fixed setting to the fastest possible shutter speed for flash operation, the sync time, leads unnecessarily in many situations to a greater or lesser underexposure of all parts of the subject not directly lit by the flash.

This camera allows you to combine flash operation with the shutter speed generated in aperture priority mode to subtly change the lighting conditions for the relevant subject to suit your compositional ideas. You can choose any of five ways of doing this:

## Setting the function

1. In the main menu (see p. 150/240) select **Auto Slow Sync.** (page 1, section **CAMERA**), and
2. in the sub-menu select the automatic lens-specific setting - **1/focal length**<sup>1</sup>, or whether you want to specify a particular shutter speed yourself - **Manual setting**.
3. In the **Manual setting** sub-menu, set the range of shutter speeds permitted by specifying the fastest speed permitted.

### Notes:

- **1/focal length** results in the slowest shutter speeds based on the rule of thumb for blur-free pictures taken from the hand, e.g.  $1/60$ s with a 50mm lens. In the **Auto Slow Sync.** menu, however, it is limited to  $1/125$ s, even if the focal length used is longer.
- The setting field in the **Manual setting** sub-menu initially shows the current slowest shutter speed setting.
- Manual exposure control also allows any shutter speed up to the sync speed of  $1/180$ s to be set.
- If an HSS-compatible Leica system flash unit is being used and faster shutter speeds than  $1/180$ s are set on the camera, the flash unit automatically switches to HSS mode.

<sup>1</sup> Only when using Leica M lenses with 6-bit coding in the bayonet and lens type detection enabled in the menu.



## SELECTING THE FIRING MOMENT

Flash photographs are illuminated by two light sources, the available light and the light from the flash. Parts of the subject that are exclusively or primarily illuminated by the flash are almost always reproduced sharply (with correct focusing) due to the extremely fast pulse of light. By contrast, all other parts of the subject – those that are sufficiently illuminated by the available light or illuminate themselves – are portrayed with different degrees of sharpness in the same picture. Whether these parts of the subject are reproduced sharply or “blurred”, and the degree of blurring, is determined by two independent factors:

1. The shutter speed, i.e. for how long these parts of the subject “act upon” the sensor, and
2. how quickly these parts of the subject – or the camera itself – are moving during exposure.

The longer the exposure time or the faster this movement, the greater the extent to which the two – superimposed – parts of the picture can differ.

With the conventional time for firing the flash, at the beginning of the exposure, i.e. immediately after the 1st shutter curtain has completely opened the image window. This can actually lead to visible contradictions, e.g. in the picture of the motorcycle, which is being overtaken by its own light trail.

The camera allows you to choose between this conventional firing moment and synchronization with the end of the exposure, i.e. immediately before the 2nd shutter curtain starts to close the image window again. In this case, the sharp image reflects the end of the movement captured. In the photograph, this flash technique gives a natural impression of movement and dynamics.

The function is available

- for all camera and flash unit settings
- when using the flash unit on the camera or with the SCA adapter set
- in aperture priority mode and with manual shutter speed selection
- in automatic and manual flash mode.

The displays are identical in both cases.

### Setting the function

1. In the main camera menu, (see p. 150/240) select **Flash Sync.** mode (page 1, section **CAMERA**), and
2. select the desired option in the sub-menu.

## ADDITIONAL FUNCTIONS

### VIDEO RECORDINGS

You can also use this camera to produce video recordings. The following functions are available:

#### Resolution / Disabling video recording

1. In the picture parameters menu (see p. 150/240) select **Video Resolution**, and
2. select the desired setting in the sub-menu. The two resolutions can be combined with two different image frequencies to match reproduction to the TV system used, 25 fps for PAL, 24 fps for NTSC. If you want to make sure that no pictures are shot when the video shutter release is accidentally pressed, select **Video OFF**.

#### ISO sensitivity

All the settings listed on pages 161-162, but with the restriction described below in respect of the shutter speeds

#### Note:

Vertical and horizontal lines may become visible all over the image, especially when shooting dark subjects with high ISO values containing very bright, spot light sources.

#### Distance setting

All the options described on pages 170-173, with the exception of detail magnification and the indication of in-focus subject details.

#### Exposure metering methods

All options described on page 174

#### Exposure modes

- Aperture priority (see p. 176)
- Manual control with shutter speeds of  $1/30 - 1/4000$ s. Set slower shutter speeds are dealt with in the same way as  $1/30$ s.

#### Sharpness, contrast

All options described on page 163

**Note:**

To ensure a consistent exposure, you should use manual shutter speed settings, otherwise changes in the subject, e.g. movements, could cause troublesome brightness fluctuations.

**Starting / ending the recording**

A recording starts the first time you press the video shutter release and ends when you press it again.

- A video recording in progress is indicated in the monitor by a flashing red dot and the elapsed recording time in Live View mode (see p. 168/234). In the viewfinder, it is indicated by alternate flashing of the two dots in the digital display. As videos are recorded in 16:9 format with this camera, black bars appears in the monitor above and below the image.

Individual pictures can still be taken while a video recording is in progress. Pressing the shutter release button interrupts the video recording for the duration of the photo. Individual pictures are taken with the relevant settings on the camera.

**SOUND RECORDING**

Sound recordings using the built-in microphone are made in mono. An external microphone is available as an accessory for stereo recording (see p. 221).

**Setting the function**

1. In the main camera menu, (see p. 150/240) select **Audio** (page 4, section **SETUP**).
  - The sub-menu contains the options **Audio Adjustment** and **Wind Elimination**.

To influence the sound, you can choose from two options or a manual setting, which you can use to regulate the level or deactivate sound recording.

2. In the Audio settings sub-menu, select **Standard**, **Concert** or **Manual**.
  - If you have selected **Manual**, next to the microphone symbol (🔊) and the current level stage setting, you will see a bar chart indicating
    - the current level
    - the peak value<sup>1</sup> (D)
    - a full modulation marking

<sup>1</sup> The peak value display shows the maximum value for the last 5s.

## Manual setting

3. Set the level using the thumbwheel - left = lower / right = higher - or by pressing up/down on the direction pad. This can also be done during the recording if you have previously pressed the **INFO** button. Level **0** means no sound recording. To prevent over-modulation, you should select the level at which the peak value does not exceed the full modulation marking at all, or only slightly/infrequently. This is illustrated by the indicators being white below this marking and red above it.

### Note:

For mono recordings, both sides (= channels) in the bar chart run parallel, or separately for stereo recording. Even for stereo recordings, the level is not controlled separately for each channel.

To reduce any noise caused by wind during the sound recording, two levels of damping are available.

2. In the **Wind Elimination** sub-menu, select **OFF**, **Medium** or **High**. When no wind noise is to be feared, you should always select **OFF** to ensure optimum sound.

## TAKING PHOTOGRAPHS WITH THE SELF-TIMER

You can use the self-timer to take a picture with a delay of either 2 or 12s. This can be particularly useful, for example in the first case if you want to avoid the picture being out of focus due to camera shake when releasing the shutter or, in the second case, for group photographs where you want to appear in the picture yourself.

### Setting and using the function

1. Turn the main switch to **S**.
2. In the main camera menu, (see p. 150/240) select **Self-timer** (page 1, section **CAMERA**) and
3. select the required delay time in the associated sub-menu.
4. To start the delay time, press the shutter release button to the 2nd pressure point (see p. 147).
  - The LED on the front of the camera flashes for the first 10s of a 12s delay time to show the progress of the delay time. The countdown is shown in the monitor at the same time.

While the self-timer delay time is running, it can be canceled at any time by pressing the **SET** or **MENU** button - the relevant setting is retained and the function can be restarted by pressing one of the shutter release buttons again.

### Important:

In self-timer mode, the exposure is not set by pressing the shutter release button to the pressure point, it is set immediately before the picture is taken.

## MARKING THE PICTURE FILES FOR COPYRIGHT PROTECTION

This camera enables you to mark your picture files by entering text or other characters.

You can enter up to 17 characters of information under 2 headings for each picture.

- In the main camera menu, (see p. 150/240), select **Copyright Information** (page 4, section **SETUP**).
  - A sub-menu containing the three options **Copyright Information**, **Information** and **Artist** appears in the monitor. Only the **Copyright Information** line is initially activated.
- Turn on the **Copyright Information** function and confirm the operation.
  - The information lines are activated and the first position is marked as ready for editing.
- Use the thumbwheel to select the desired characters and press the relevant direction on the direction pad to move between positions.

You move to the **Artist** lines either by pressing the appropriate directions on the direction pad or using the **INFO** or **SET** button.

The available characters include various punctuation marks, numbers from 0 to 9, upper and lower case letters and a space which appear in this order in an endless loop.

- Confirm your setting by pressing the **SET** or **INFO** button.

## RECORDING THE LOCATION WITH GPS





This option is only available if the multifunction M hand grip is attached (available as accessory, see p. 220).

The **Global Positioning System** enables the current position of a receiver to be determined worldwide. The multifunction hand grip is equipped with an appropriate receiver. If the hand grip is attached to the camera, when the function is activated the camera continuously receives the corresponding signals and updates the position data. You can write this information - latitude and longitude, height above sea level - to the "EXIF" data.

### Note:

The corresponding menu function on the camera is only available when the multifunction hand grip is attached.

### Setting the function

- In the main camera menu, select **GPS** (page 4/section **SETUP**, and
- select **ON** or **OFF**.
  - The satellite symbol () in the monitor indicates the status (only with picture data display):
    -  = Last position determined up to 1 minute ago
    -  = Last position determined up to 5 minutes ago
    -  = Last position determined at least 5 minutes ago, or no position data available

**Notes on the function:**

- The GPS aerial is located at the top of the multifunction M hand grip.
- GPS positioning requires as clear a path as possible between this aerial and the sky. We therefore recommend holding the camera with the GPS aerial pointing vertically upwards.
- It may take a few minutes to locate the position. This can occur especially when so much time has elapsed between turning the camera off and back on that the satellites have moved significantly and have to be re-located.
- Make sure that the GPS aerial is not covered with your hand or any other item, particularly metal objects.
- It may not be possible to receive good signals from GPS satellites at the following locations or in the following situations. In such cases, positioning may not be possible at all, or may be incorrect:
  - In closed rooms
  - Underground
  - Under trees
  - In a moving vehicle
  - Close to high buildings or in steep valleys
  - Close to high voltage cables
  - In tunnels
  - Close to 1.5 GHz mobile telephones
  - With accessories attached to the accessory shoe, e.g. a flash unit

**Information for safe use**

The electromagnetic field generated by the GPS system can influence instruments and measuring equipment. Therefore, make sure the GPS function is deactivated on board an aircraft before takeoff or landing, in hospitals or in other locations where there are restrictions on wireless transmissions.

**Important (legal restrictions on use):**

- In certain countries or regions, the use of GPS and associated technologies may be restricted. Therefore, before traveling in other countries you should consult the relevant country's embassy or your travel agent.
- The use of GPS inside the People's Republic of China and Cuba and close to their borders (exceptions: Hong Kong and Macao) is prohibited by national laws. Violations will be prosecuted by the authorities. The GPS function is therefore deactivated automatically in these areas.

## USER/APPLICATION-SPECIFIC PROFILES

On this camera, any combination of menu settings can be permanently stored, e.g. so that they can be retrieved quickly and easily at any time for recurring situations / subjects. A total of four memory slots are available for these combinations, as well as a factory default setting that can be retrieved at any time and cannot be changed. You can change the names of the saved profiles.

Profiles set on the camera can be transferred onto a memory card, for example for use in other camera units, while profiles stored on a card can be transferred onto the camera.

### Saving settings / Creating a profile

1. Set the desired functions in the menu.
2. In the picture parameters menu (see p. 150/240), select **User Profile**,
3. select **Save as user profile** in the sub-menu, and
4. select a memory slot in the sub-menu.

## Selecting a profile

1. In the picture parameters menu (see p. 150/240), select **User Profile**.
  - If user profiles are stored, the profile name appears in gray, while free memory slots are green.
2. Select the required profile in the sub-menu, either one of the saved profiles, or **Default user profile**.

### Note:

If you change one of the settings for the profile currently in use — appears instead of the name of the profile you were previously using in the initial menu list.

## Renaming profiles

1. In the picture parameters menu (see p. 150/240), select **User Profile**,
2. select **Manage profiles** in the sub-menu, and
3. select **Rename profiles** in the sub-menu.
  - The profile name and name appear, with the number marked as ready for editing.
4. Select the profile to be renamed by turning the thumbwheel or pressing up or down on the direction pad.
5. Confirm your setting by pressing the **SET** or **INFO** button or by pressing right on the direction pad.
  - The next position is marked as ready for setting.
6. The numbers and letters in the name are changed by turning the thumbwheel or by pressing up and down on the direction pad, while you select different positions by pressing either
  - the **INFO** button,
  - or the **SET** button,
  - or left or right on the direction pad.

The available characters are upper case letters from **A** to **Z**, the numbers from **0** to **9** and a space  which appear in this order in an endless loop.
7. Confirm your setting - only possible if the last position is active - by pressing the **SET** or **INFO** button.



### Saving profiles to a card / transferring profiles from a card

1. In the picture parameters menu (see p. 150/240), select **User Profile**,
2. select **Manage profiles** in the sub-menu, and
3. select **Import profiles from card** or **Export profiles to card**.
  - A confirmation prompt appears in the monitor.
4. Confirm your setting by pressing the **SET** or **INFO** button, and confirm that you really want to import or export the profile(s).

#### Note:

When exporting, all profile slots are transferred to the card, i.e. including any empty profiles. As a result, when importing profiles any existing profiles in the camera will be overwritten, i.e. deleted.

### RESETTING ALL CUSTOM SETTINGS

This function allows you to delete all previous custom settings in the main and picture parameters menus at once, and reset them to the factory default settings.

#### Setting the function

1. In the main camera menu, (see p. 150/240) select **Reset** (page 5/section **SETUP**), and
2. select **No** or **Yes** in the sub-menu.

#### Note:

This reset also affects any stored individual user profiles defined.

## REVIEW MODE

To review pictures in the monitor, you can select:

- **PLAY** Review for an unlimited time

or

- **Auto Review** Brief review immediately after taking the picture

## REVIEW FOR UNLIMITED TIME – PLAY

By pressing the **PLAY** button you can switch to review mode.

- The last picture taken appears in the monitor along with the corresponding displays (see p. 237).

However, if the memory card inserted does not contain any image files, the following message appears when you switch to review mode: **Caution: No image to display.**

## Notes:

- Depending on the function previously set, pressing the **PLAY** button generates different responses:

Initial situation	After pressing the <b>PLAY</b> button
a. Full review display of a picture	Picture mode
b. Review of an enlarged section / several reduced pictures (see p. 213)	Full review display of the picture
c. One of the menu controls (see p. 150), or <b>DELETE</b> or delete protection function (see p. 206/88) is activated.	Full review display of the last displayed picture

- This camera can only review picture data taken with cameras of this type.

## AUTOMATIC REVIEW OF LAST PICTURE

In **Auto Review** mode, each picture is displayed immediately after it is taken.

This allows you to quickly and easily check whether the picture was successful or needs to be taken again.

This function enables you to select the time for which the picture will be displayed.

### Setting the function

1. In the main camera menu, (see p. 150/240) select **Auto Review** (page 4/section **SETUP**),
2. In the associated sub-menu select the desired function or time: (**OFF**, **1 second**, **3 seconds**, **5 seconds**, **Continuous**, **Shutter release pressed**).

From **Auto Review** mode, you can switch back at any time to normal, i.e. unlimited, **PLAY** review mode.

### Note:

If you have been taking photographs using the picture series function (see p. 148), in both review modes the last picture in the series or the last picture in the series stored on the card - if not all pictures in the series have been transferred from the camera's internal back-up memory to the card at this point - is displayed first. Details of how to select the other pictures in the series and further options in review mode are described in the sections below.

## Normal review

To allow uninterrupted viewing of the pictures, only the information in the header appears in normal review mode.

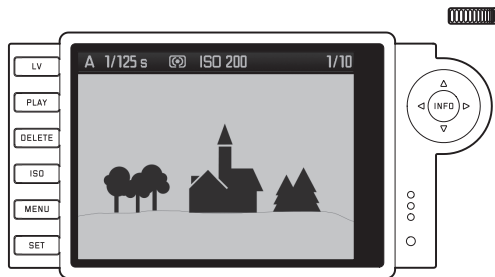

If a detail is shown, the header disappears and a corresponding display appears .

## Video review

If a video recording is selected, this is indicated by .



To play back a video, press the **INFO** button to call up the next view, which contains corresponding control symbols.

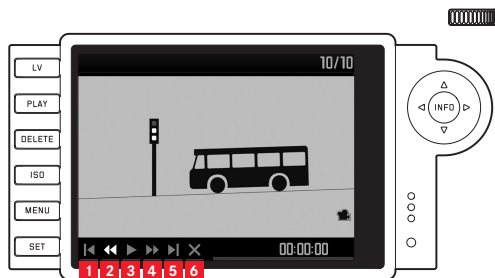

- 1** Back to beginning
- 2** Fast rewind
- 3** Play/Pause
- 4** Fast forward
- 5** To end
- 6** Exit view

Select the desired function by pressing right/left on the direction pad or using the thumbwheel. It is activated by pressing the **SET** button, either by pressing it or, for fast forward/rewind, holding it down. This starts in slow motion and gets faster the longer the button is held down for.

- The currently active function symbol is shown in white and underlined in red.

**Note:**

From this view, the menu for protecting (see p. 208) cannot be called up. To do this, switch to another view by pressing the **INFO** button.

In addition to normal review, a further 3 (for individual pictures) or 2 (for video recordings) options with different additional information are available. All 4 or 3 options are in an endless loop and can be selected by (repeatedly) pressing the **INFO** button.

## Review with histogram

Press the **INFO** button once (starting from normal review mode), to display the histogram. It appears in the lower half of the picture.

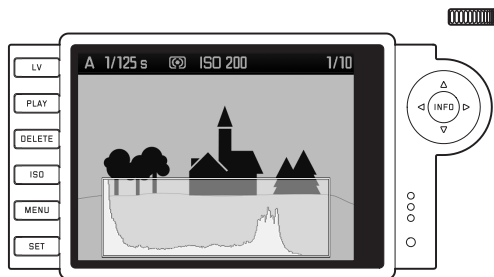

## Notes:

- The histogram is available both when reviewing the entire picture and when showing a detail, but not when simultaneously reviewing 4, 9 or 36 smaller pictures (see p. 205).
- The histogram always relates to the detail of the picture currently displayed (see p. 238).

## Review with clipping indicators

You can use the menu to set the clipping thresholds for displaying both the light and dark areas.

Press the **INFO** button twice (starting from normal review mode), to display the areas without marking.

- Excessively light areas are indicated in red, excessively dark areas in blue, flashing in each case. The clipping symbol (L) also appears in the bottom right.

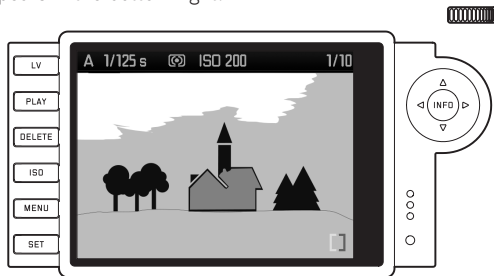

## Setting the function

- In the main camera menu, (see p. 150/240) select **Clipping** (page 3/ section **SETUP**), and
- set the upper and lower thresholds in the sub-menu.
  - The scale shows the clipping areas relative to the overall exposure range.

### Notes:

- The clipping indicators are available when viewing both the entire picture and a section of it, but not when simultaneously viewing 4, 9 or 36 reduced pictures (see p. 205).
- The clipping indicators always relate to the detail of the picture currently displayed (see p. 205).

## Review with additional information

Press the **INFO** button three times (starting from normal review mode) to display additional picture data and a reduced picture.



### Note:

This review option only allows you to view the entire picture, even if only a section was previously selected.

## VIEWING OTHER PICTURES / SCROLLING IN THE MEMORY

You can open other saved pictures by pressing left and right on the direction pad. Pressing left takes you to earlier pictures, pressing right to later pictures. After the first and last picture, the series of pictures begins again in an endless loop, which means you can reach all pictures in either direction.

- The picture and file numbers in the monitor change accordingly.

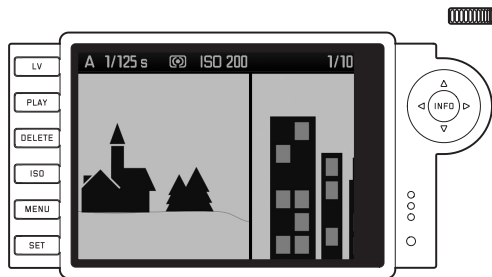



## ENLARGING / SELECTING THE TRIMMING / SIMULTANEOUSLY VIEWING SEVERAL REDUCED PICTURES

With this camera it is possible to open an enlarged section of an individual picture in the monitor to study it more closely, with a free choice of section. Conversely, you can also view up to 36 pictures simultaneously in the monitor, e.g. to gain an overview or to find the picture you are looking for more quickly.

### Notes:

- Not all zoom levels are available for pictures with low resolution, e.g. 1.7 MP.
- While an enlarged picture is displayed, left/right on the direction pad are no longer available to open other pictures, instead they are used to "navigate" within the picture (exception: see next note).

Turning the thumbwheel to the right enlarges a central trimmed area. Enlargement is possible up to 1:1, i.e. until 1 pixel of the monitor displays 1 pixel of the picture.

The four directions on the direction pad can be used to select any position for the section to be enlarged. To do this, press the direction (several times) in which you want to shift the section.

- In addition to the enlargement, the rectangle within the frame in the top right-hand corner of the monitor symbolizes the position of the section displayed.

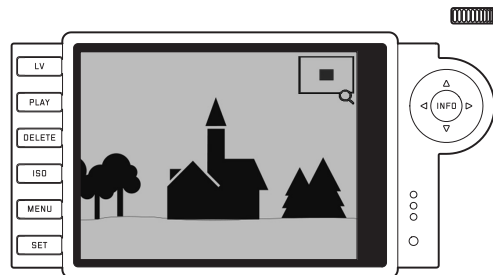
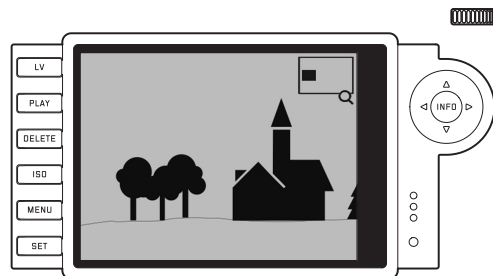

**Note:**

You can also switch from an enlarged picture directly to another picture, which will then be shown at the same enlargement. This is done by pressing left or right on the direction pad - but while holding down the **PLAY** button.

By turning the thumbwheel to the left (starting from normal size), you can simultaneously view 4 - or by turning the dial further 9 or 36 - pictures in the monitor.

- Up to 36 reduced images are shown in the monitor including the picture previously being viewed at normal size, which is marked with a red border.

You can use the four directions on the direction pad to navigate freely among the reduced images, and the relevant image is marked accordingly. You can return this picture to normal size by turning the thumbwheel to the right or by pressing the **INFO** or **PLAY** button.

**Note:**

When 36 pictures are displayed, turning the thumbwheel further to the right places the red frame around the entire group of pictures, which then allows you to scroll more quickly, a block at a time.

**DELETING PICTURES**

When a picture is displayed in the monitor, you have an opportunity to delete it if you wish to do so. This can be useful, for example if the pictures have already been saved to other media, if you no longer require them or if you need to free up more space on the memory card.

You can delete single pictures, or all pictures at the same time, as required.

**Notes:**

- Deleting is only possible in review mode, but regardless of whether a picture is being displayed at normal size or several reduced pictures are displayed (but not if the 36 picture review is activated with a red frame around the entire block).
- For protected pictures, the protection must first be canceled before they can be deleted (see also next section).

**Procedure**

1. Press the **DELETE** button.
  - The corresponding sub-menu appears in the monitor.

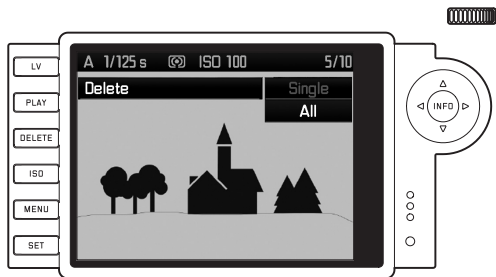
**Note:**

The delete process can be canceled at any time using the **PLAY** or **DELETE** button.

- The first step is to decide whether you want to delete individual pictures - **Delete single** - or all pictures at once - **Delete all**.
- Confirm your selection with the **SET** button. You can still open other pictures by pressing right and left on the direction pad.

**Notes:**

- If the picture shown is protected (see p. 208), the **Single** option cannot be selected in the sub-menu.
- When deleting all pictures, to prevent accidental deletion there is an intermediate step in which you must reconfirm that you definitely want to delete all pictures on the memory card.

**Displays after deleting**

After deleting, the subsequent picture appears. If there are no more pictures saved on the card, the following message appears: **Attention No image to display**.

**Deleting all pictures on the memory card**

After deleting, the following message appears: **Attention No image to display**. However, if one or more pictures were protected, that picture or the first of those pictures then appears.

**Note:**

When a picture is deleted, the subsequent pictures in the picture counter are re-numbered as follows: For example, if you delete picture no. 3, what was previously picture no. 4 then becomes no. 3, the previous no. 5 becomes no. 4 and so on. However, this does not apply to the picture numbering on the memory card.

## PROTECTING PICTURES / CLEARING DELETE PROTECTION

The pictures stored on the memory card can be protected against accidental deletion. This protection can then be cleared at any time.

### Notes:

- Pictures can only be protected, or the protection can only be cleared, in review mode, irrespective of whether a picture is displayed at normal size or as one of several reduced pictures (but not when viewing 36 pictures with a red frame round the entire block, see p. 205).
- For details of the different procedures/responses when you attempt to delete protected pictures, refer to the previous section.
- If you decide you want to delete them, clear the protection as described below.
- Protection is only effective on the camera.
- Even protected pictures are deleted if the memory card is reformatted (see next section for details).
- On SD memory cards, you can prevent accidental deleting by sliding the write protection switch on the card (see p. 141) to the position marked LOCK.

### Procedure

1. Press the **SET** button.
  - The corresponding sub-menu appears in the monitor.

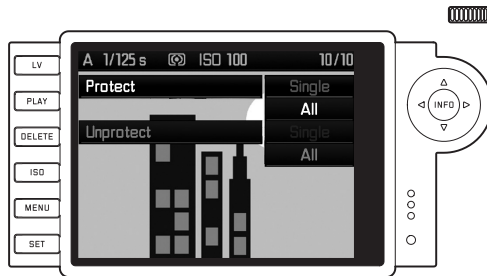

### Note:

- The setting process can be canceled at any time
- either by pressing the **PLAY** button - to return to normal review mode,
  - or by tapping the shutter release button to go to picture mode.

2. Select
  - whether you want to protect individual pictures - **Protect single**, or
  - simultaneously protect all pictures - **Protect all**, or
  - whether you want to clear the existing protection for individual pictures - **Clear protection Single**, or
  - for all pictures - **Clear protection All**.

**Note:**

The following functions cannot be performed and the menu text appears in dark instead of light gray to indicate this:

- Protecting a picture that is already protected
  - Clearing delete protection for a picture that is not protected
3. Confirm your selection with the **SET** button. You can still open other pictures by pressing right and left on the direction pad.

**Displays after protection / clearing protection**

After completing the process, the original monitor display appears again, with the corresponding symbol (Ⓢ) for protected pictures.

**Note:**

The display (Ⓢ) also appears if a protected picture is called up.

## ADDITIONAL FUNCTIONS

### FOLDER MANAGEMENT

The picture data on the memory card is stored in folders, which are created automatically. The folder names always consist of eight characters - three figures and five letters. In the factory default setting, the first folder is named "100LEICA", the second "101LEICA", etc. The next available number is always used as the folder number, and a maximum of 999 folders are possible. The next free number is always assigned as the folder number; a maximum of 999 folders are possible. If the number capacity is exhausted, a corresponding warning message appears in the monitor.

Within the folder, the individual pictures are given continuous numbers up to 9999 unless a the memory card in use already contains a picture with a higher number than the last number assigned by the camera. In such cases, the numbering used on the card is continued. If the current folder contains picture number 9999, a new folder is created automatically and the numbering begins again at 0001. If folder number 999 and picture number 9999 are reached, a corresponding warning message appears in the monitor and the numbering must be reset (see below).

On this camera you can also create new folders at any time, give them names of your choice and change the file names.

### Changing folder name

1. In the main camera menu, (see p. 150/240) select **Image numbering** (page 4/section **SETUP**), and
2. select **New folder** in the sub-menu.
  - The folder name appears (initially always **XXXLEICA**). The fourth character is marked as ready for editing. Positions 4-8 can be changed.

#### Note:

If you are a using memory card that was not formatted with this camera (see p. 212), the camera automatically creates a new folder.

3. The numbers and letters are changed by turning the thumb-wheel or by pressing up and down on the direction pad, while you select different positions by pressing
  - the **INFO** button,
  - or the **SET** button,
  - or left or right on the direction pad.

The available characters are upper case letters from **A** to **Z**, the numbers from **0** to **9** and the underscore **\_** which appear in this order in an endless loop.

<sup>1</sup> The **X** characters are placeholders.

4. Confirm your settings - only possible if the eighth position is active - by pressing the **SET** or **INFO** button.
  - A further sub-menu appears, showing **Reset image numbering?**.
5. Select **Yes** or **No**.

### Changing picture file names

1. In the main camera menu, (see p. 150/240) select **Image numbering** (page 4/section **SETUP**), and
2. select **Change file name** in the sub-menu.
  - The name of the picture file appears. The first character is marked as ready for editing.  
Positions 1-4 can be changed.
3. The numbers and letters are changed by turning the thumb-wheel or by pressing up and down on the direction pad, while you select different positions by pressing
  - the **INFO** button,
  - or the **SET** button,
  - or left or right on the direction pad.The available characters are upper case letters from **A** to **Z**, the numbers from **0** to **9** and the underscore **\_** which appear in this order in an endless loop.
4. Confirm your settings - only possible if the fourth position is active - by pressing the **SET** or **INFO** button.
  - The setting menu described under 2. appears again.

## Resetting picture file names

1. In the main camera menu, (see p. 150/240) select **Image numbering** (page 4/section **SETUP**), and
2. select **Reset** in the sub-menu.
  - A further sub-menu appears, showing **Reset image numbers?**.
3. Select **Yes** or **No**.
  - After confirming your selection by pressing the **INFO** or **SET** button, the setting menu described under 2. appears again.

## FORMATTING THE MEMORY CARD

It is not normally necessary to format memory cards that have already been used. However, if a card that has yet to be formatted is inserted for the first time, it must be formatted.

### Note:

You should get into the habit of copying all your pictures onto a secure bulk storage medium, e.g. the hard drive on your computer, as soon as possible. This is particularly important if the camera is being sent for servicing along with the memory card.

### Procedure

1. In the main camera menu, (see p. 150/240) select **Format SD card** (page 5, section **SETUP**), and
2. select **Format SD card?** in the sub-menu.
3. Press the **SET** or **INFO** button to format the memory card.

### Notes:

- If the memory card has been formatted in another device, such as a computer, you should reformat it in the camera.
- If the memory card cannot be formatted/overwritten, you should ask your dealer or the Leica Product Support department (for address, see p. 248) for advice.



## TRANSFERRING DATA TO A COMPUTER

The picture data on a memory card can be transferred to a computer in two ways:

- Using the multifunction M hand grip (see p. 220)  
This accessory has a USB 2.0 interface that allows the memory card in the camera to be read out.
- Using a card scanner for SD/SDHC/SDXC cards  
The camera is compatible with the following operating systems:
  - Microsoft®: Windows® XP / Vista® / 7® / 8®
  - Apple® Mac® OS X (10.6 or higher)

### Notes:

- Details of how to attach the hand grip, its functions and how to use it can be found in its instructions.
- Connecting two or more devices to a computer or connecting using a USB hub or extension cables can result in malfunctions.

## USB connection

Data can be transferred via USB cable using two different standards. It thus takes account of the fact that some operating systems for transferring picture data require a connection complying with the PTP protocol.

In addition, it is always possible to operate the camera as an external drive ("mass storage").

### Setting the function

1. In the Main Menu (see p. 150/240) select **USB mode** (page 5, section **SETUP**), and
2. select **PTP** or **Mass Storage** in the sub-menu.

### Connecting and transferring data using the PTP protocol

If the camera is set to **PTP**:

3. Use the USB cable (supplied with the hand grip) to connect the USB socket on the multifunction M hand grip to a USB port on the computer.

**With Windows® XP**

- After connecting, a message appears to confirm that the camera has been detected as new hardware (initial connection only).
4. Double-click on the message.
    - A pull-down menu entitled “M Digital Camera” opens for the data transfer wizard.
  5. Click on “OK” and follow the subsequent instructions in the wizard to copy the pictures to a folder of your choice in the normal way.

**With Windows® Vista® / 7® / 8®**

- After connection, a message about installation of the device driver software appears above the taskbar.  
At the same time, **USB connection** appears in the camera monitor.  
Successful installation is confirmed by another message. The “Automatic Review” menu opens with various device options.
5. You can use the Windows wizard to "Import Images" or "Open Device to View Files" in the normal way.

**With Mac® OS X (10.5 or higher)**

- Once the camera has been successfully connected to the computer, **USB Connection** appears in the camera monitor.
4. Open the “Finder” on the computer.
  5. In the left window, click on “Programs” in the “Locations” category.
  6. Select the “Digital Images” program in the right window.
    - The program opens and the name “M Digital Camera” appears in the program title bar.
  7. The pictures can now be transferred to the computer using the “Load” button.

## Transferring data with the camera as an external drive (mass storage)

**Precondition:** The camera/multifunction M hand grip combination is connected to the computer via the USB cable.

- Under Windows® operating systems:

The camera connected to the computer using the USB cable is detected as an external drive by the operating system and is assigned a drive letter.

- Under Mac® operating systems:

If the camera is connected to the computer using the USB cable, the memory card used appears as a storage medium on the desktop. With this method, the Finder can be used to access the files directly.

### Notes:

- The 100LEICA, 101LEICA, etc. folders can hold up to 9999 pictures.
- As long as this function is active, all other camera functions are blocked.

### Important:

- Use only the USB cable supplied with the hand grip.
- While data is being transferred from the camera to the computer, the USB cable connection must not under any circumstances be interrupted, as otherwise the computer and/or the camera may crash, and the memory card may even be irreparably damaged.
- While data is being transferred from the camera to the computer, the camera must not be turned off or turn itself off due to a lack of battery capacity, as otherwise the computer can crash. It is therefore to be recommended that data are only transferred when the camera has sufficient battery capacity or when using the mains unit of the multifunction M hand grip.
- Should the battery capacity become exhausted during the process, stop the transfer and switch off the camera. Repeat the process for the data not yet transferred using a fully charged battery or with connected mains unit.

**ADOBE® PHOTOSHOP® LIGHTROOM®**

Adobe® Photoshop® Lightroom® is available as a free download when you register your camera on the Leica Camera AG website. Further details can be found in the "Customer Area" under: [www.members.leica-camera.com](http://www.members.leica-camera.com) or on the registration card in the camera packaging.

**LEICA IMAGE SHUTTLE**

The exclusive Leica Image Shuttle software enables you to remotely control the camera from a computer and to directly store the image data on the computer's hard drive for "tethered shooting". All of the key camera functions can be controlled. This convenient solution provides ideal support in the studio and on location.

Leica Image Shuttle is available as a free download when you register your camera on the Leica Camera AG website. Further details can be found in the "Customer Area" under: [www.members.leica-camera.com](http://www.members.leica-camera.com) or on the registration card in the camera packaging.

**Note:**

This function is only available with the multifunction M hand grip (see p. 220).

**WORKING WITH DNG RAW DATA**

If you have selected DNG (Digital Negative) format, you require specialist software to convert the saved raw data into optimum quality, for example the professional raw data converter Adobe® Photoshop® Lightroom®. It provides quality-optimized algorithms, delivering exceptionally low noise photographs with incredible resolution.

During editing, you have the option of adjusting parameters such as noise reduction, gradation, sharpness etc. to achieve an optimum image quality.

## INSTALLING FIRMWARE UPDATES

Leica is constantly working on developing and optimizing its products. As many functions of the camera are entirely controlled by software, some of these improvements and extended functions can be installed at a later date.

Leica provides firmware updates at irregular intervals for this purpose.

Information about any resulting changes or additions to the details in its instructions can be found on our website.

To check whether your camera is running the latest firmware version, select **Firmware** (page 5/section **SETUP**).

You can download new firmware from our website and transfer it to your camera:

1. Format a memory card in the camera.
2. Turn off the camera and insert the card into an SD/SDHC/SDXC card reader – either integrated or connected to your computer.
3. Download the firmware file from the camera page using the “UPDATES” link.
4. Save the file m-X\_XXX.upd at the top level of the card's folder structure. X\_XXX stands for the relevant version.
5. Remove the card from your card reader and insert it in the camera. Close the bottom cover and turn the camera on.

6. Hold down the **INFO** button and turn on the camera.

The update process begins. This can take up to 15 minutes.

### Notes:

- If the battery does not have sufficient charge, the warning message **Battery low** appears. In this case, first charge the battery and then repeat the process described above.
- Observe all the instructions concerning putting the camera into operation again.

## MISCELLANEOUS

### SYSTEM ACCESSORIES

#### INTERCHANGEABLE LENSES

The Leica M system provides a basis for optimum adaptation to fast and unobtrusive photography. The range of lenses incorporates focal lengths from 16 to 135mm and light intensities up to 1:0.95.

#### R ADAPTER M

The Leica R adapter M allows almost all Leica R lenses to be used on the Leica M Monochrom, i.e. regardless of the focal length, fixed focal length or zoom, close up limit, with which actuating cam they are equipped (SL "ramps" / R "steps") and whether or not they have a ROM contact strip.

It is also possible to use these lenses in conjunction with Leica Extender R models, and with close-up accessories such as the Leica Macro Adapter R, Leica R intermediate rings and the R BR2 automatic bellows.

This enables the camera to be used for applications that are not normally possible for a view and range finder camera, such as pictures with extremely short or long focal lengths, and extreme close up shots.

(Order No. 14 642)

## FILTERS

UVA filters and a universal polarization filter M are available for current Leica M lenses with standard filter thread sizes.

#### EVF2 ELECTRONIC VIEWFINDER

The EVF2 delivers almost 100% TTL reproduction of the image field with a resolution of 1.4 megapixels. This allows easy and precise picture composition along with complete control of all relevant data. It is particularly useful when the lighting conditions impair the visibility of the monitor screen and - thanks to the pivoting eyepiece - for worm's eye view pictures.

(Order No. 18 753)

#### Note:

Make sure the accessory shoe cover is always attached when no accessories are in use (such as a flash unit, an external viewfinder or microphone). It will protect the socket 28 for a time against water incursion.

### UNIVERSAL WIDE ANGLE VIEWFINDER M

The Leica universal wide-angle viewfinder M is a thoroughly practical accessory. It can be used without restriction on all analog and digital Leica M models and – just like the viewfinder in the camera – uses a reflected bright-line frame to outline the picture area for wide angle focal lengths 16, 18, 21, 24 and 28mm. The viewfinder is equipped with parallax compensation and a vial (spirit level) for exact leveling of the camera.  
(Order No. 12 011)

### MIRROR VIEWFINDER M

Mirror viewfinders are available for 18, 21, and 24mm lenses. They feature an exceptionally compact design and a bright viewfinder image. Bright line frames like those in the camera viewfinder are used to select the trimming (order no. 18mm: 12 022 black, 12 023 silver / 21mm: 12 024 black, 12 025 silver / 24mm: 12 026 black / 12 027 silver).

### VIEWFINDER MAGNIFIERS M 1.25x AND M 1.4x

The Leica M 1.25x and M 1.4x viewfinder magnifiers significantly simplify picture composition when using focal lengths above 35mm. They can be used on all Leica M models and magnify the central area of the viewfinder image. The 1.25x viewfinder magnifier gives the 0.68 x viewfinder on this camera a magnification of 0.85 x, while the 1.4 x gives 0.95 x magnification. A security chain with snap fasteners prevents loss and can be used to hang the viewfinder on the carrying strap's fastening ring. The viewfinder magnifiers are supplied in a leather bag. A loop on the case allows the viewfinder magnifier to be stored on the camera's carrying strap, where it is protected and ready for use.  
(Order no. 12 004 M 1.25x, 12 006 M 1.4x)

## FLASH UNITS

With its compact dimensions and design that matches the camera, the Leica SF 26 system flash unit is the perfect solution. It is also extremely easy to operate.

(Order No. 14 622)

## HAND GRIP M

As a practical accessory, we recommend the M8 hand grip, which allows you to hold the Leica M Monochrom extremely steadily and to carry it with one hand. It is attached in place of the standard bottom cover.

(Order No. 14 496)

## MULTIFUNCTION HAND GRIP M

As for the M hand grip. The multifunction M hand grip is also equipped with a GPS aerial, which enables the location coordinates to be added to picture data. In addition, it has connections for data transmission via USB cable, mains operation with AC adapter M, flash firing with standard commercial synchronous cables and - in conjunction with an SCA adapter set - TTL control of external, compatible flash units.

(Order No. 14 495)

## SCA ADAPTER SET FOR MULTIFUNCTION HAND GRIP M

The adapter set is made up of a rail and the SCA connecting cable. Combined with an attached multifunction M hand grip, it provides TTL controlled flash, even if the flash unit will not be attached to the camera, e.g. for indirect illumination, or when using an attachable viewfinder at the same time. It is also possible to use two flash units simultaneously, one on the camera, one using the adapter set.

(Order No. 14 498)



### MICROPHONE ADAPTER SET

The microphone adapter M allows sound recording in stereo for video recordings. When mounted in the accessory shoe on the camera, all necessary connections are made simultaneously. (Order No. 14 634)

### CORRECTIVE LENSES

For optimum adaptation of the eye to the camera's viewfinder, we offer corrective lenses with the following positive or negative diopter values (spherical):  $\pm 0.5/1/1.5/2/3$ .

### AC ADAPTER FOR MULTIFUNCTION HAND GRIP M

The mains unit allows the camera to be continuously operated (with the multifunction M hand grip attached) directly from the mains. (Order No. 14 497)

### FINGER LOOP M FOR MULTIFUNCTION HAND GRIP M

The finger loops are screwed into the multifunction M hand grip or the M hand grip and provide a secure hold on the camera, particularly when it is being carried and when using long and heavy lenses. (Order No. S: 14 646/M: 14 647/L: 14 648)

### CASES

The M ever-ready case protects the camera reliably during transport and can be left connected to the camera so that the camera can be used quickly when taking photographs. For effective protection during intensive photography, the front of the case can be detached and the section remaining on the camera then acts as a camera protector. (Order No. 14 547)

For your full set of camera equipment, the classic Billingham combination case made of waterproof fabric is also available. This either holds two cameras and two lenses or one camera and three lenses. It has enough space for even large lenses and an attached multifunction M hand grip. A zipped compartment also provides space for a Leica SF 26 flash and for other accessories. (Order no. 14 854 black, 14 855 khaki)

<b>SPARE PARTS</b>	<b>Order No.</b>
Camera cover M	14 397
Accessory shoe cover M	14 644
Carrying strap	14 312
Li ion battery BP-SCL2	14 499
Charger BC-SCL2 (with EU/USA mains cables, in-car charging cord)	14 494
Mains cable for AUS and UK	14 422 / 14 421

## SAFETY AND CARE INSTRUCTIONS

### GENERAL PRECAUTIONS

- Do not use your camera in the immediate vicinity of devices with powerful magnetic, electrostatic or electromagnetic fields (e.g. induction ovens, cookers, microwave ovens, television sets or computer monitors, video game consoles, cell phones, radio equipment).
- If you place the camera on or very close to a television set, its magnetic field could interfere with picture recordings.
- The same applies for use in the vicinity of cell phones.
- Strong magnetic fields, e.g. from speakers or large electric motors, can damage the stored data or the pictures.
- Do not use the camera in the immediate vicinity of radio transmitters or high-voltage power lines. Their magnetic fields can also interfere with picture recordings.
- If the camera malfunctions due to the effects of electromagnetic fields, remove the battery and turn the camera on again.
- Protect the camera from contact with insect sprays and other aggressive chemicals. Petroleum spirit, thinner and alcohol may not be used for cleaning.
- Certain chemicals and liquids can damage the camera's housing or the surface finish.
- As rubber and plastics sometimes emit aggressive chemicals, they should not remain in contact with the camera for a long time.
- Ensure that sand and dust cannot get into the camera, e.g. on the beach. Sand and dust can damage the camera and the memory card. Take particular care when changing lenses and when inserting and removing the card.
- Ensure that water cannot get into the camera, e.g. when it is snowing or raining and on the beach. Moisture can cause malfunctions and even permanent damage to the camera and the memory card.
- Make sure the accessory shoe cover is always attached when no accessories are in use (such as a flash unit, an external viewfinder or microphone). It will protect the accessory shoe and socket for a time against the ingress of water.
- If salt water spray gets onto the camera, wet a soft cloth with tap water, wring it out thoroughly and wipe the camera with it. Then wipe down thoroughly with a dry cloth.

## MONITOR

The monitor is manufactured using a high-precision process. This ensures that of the total of more than 921,600 pixels only a very small number will not work correctly, i.e. remain dark or always be lit. However, this is not a malfunction and it does not impair the reproduction of the picture.

- If the camera is exposed to significant temperature fluctuations, condensation can form on the monitor. Wipe it carefully with a soft dry cloth.
- If the camera is very cold when it is turned on, the displays may at first appear darker than usual. As soon as it warms up, it will reach its normal level of brightness.

## SENSOR

- Cosmic radiation (e.g. on flights) can cause pixel defects.

## CONDENSATION MOISTURE

- If condensation has formed on or in the camera, you should turn it off and leave it to stand at room temperature for around an hour. Once the camera temperature has adjusted to room temperature, the condensation will disappear by itself.

## CARE INSTRUCTIONS

As any soiling also represents a growth medium for microorganisms, you should take care to keep the equipment clean.

### FOR THE CAMERA

- Clean the camera only with a soft, dry cloth. Stubborn dirt should first of all be covered with a well-thinned cleaning agent and then wiped off with a dry cloth.
- To remove stains and fingerprints, the camera and lens should be wiped with a clean lint-free cloth. Tougher dirt in hard to reach corners of the camera body can be removed with a small brush. The shutter blades may not be touched when doing this.
- All mechanically operated bearings and sliding surfaces on your camera are lubricated. Please remember this if you will not be using the camera for a long period of time. To prevent the lubrication points becoming gummed up, the camera shutter should be released a number of times every three months. It is also recommended that you repeatedly move and use all other controls. The range and aperture adjustment rings on the lens should also be moved periodically.
- Take care that the sensor for the 6-bit coding in the bayonet fastening does not become soiled or scratched. Take care also that no grains of sand or similar particles enter the fastening, where they could scratch the bayonet. Only clean this component when dry and do not exert any pressure on the glass cover.

### FOR LENSES

- Normally, a soft hair brush is sufficient to remove dust from the outer lens elements. However, in case of more stubborn dirt, they can be carefully cleaned with a very clean, soft cloth that is completely free of foreign matter, using circular motions from the inside to the outside. We recommend micro-fiber cloths (available from photographic and optical specialists) that are stored in a protective container and can be washed at temperatures of up to 40°C / 108°F (without fabric softener, never iron!). Cloths for cleaning glasses, which are impregnated with chemicals, should not be used as they can damage the lens glass.
- Take care that the 6-bit coding in the bayonet fastening does not become soiled or scratched. Take care also that no grains of sand or similar particles enter the fastening, where they could scratch the bayonet. Never wet this component when cleaning it!
- For optimum front lens protection in unfavorable photographic conditions (e.g. sand, salt water spray), use transparent UVA filters. However, you should bear in mind that, like all filters, they can cause unwanted reflections in certain backlight situations and with high contrasts. The generally recommended lens hood also protects the lens from unintentional fingerprints and the rain.

## FOR THE BATTERY

Rechargeable lithium ion batteries generate power through internal chemical reactions. These reactions are also influenced by the external temperature and humidity. Very high or low temperatures reduce the life of the battery.

- Always remove the battery, if you will not be using the camera for a long period of time. Otherwise after several weeks the battery could undergo deep discharge, i.e. the voltage is sharply reduced, as the camera still consumes a small amount of current (e.g. for saving the date) even when it is turned off.
  - Lithium ion batteries should only be stored in a partially charged condition, i.e. not completely discharged or fully charged (in the corresponding display in the monitor). For very long storage periods, it should be charged up and discharged again around once a year.
  - Always ensure that the battery contacts are clean and freely accessible. While lithium ion batteries are proof against short circuits, they should still be protected against contact with metal objects such as paper clips or jewelry. A short-circuited battery can get very hot and cause severe burns.
  - If a battery is dropped, check the casing and the contacts immediately for any damage. Using a damaged battery can damage the camera.
- In case of noise, discoloration, deformation, overheating or leaking fluid, the battery must be removed from the camera or charger immediately and replaced. Continued use of the battery results in a risk of overheating, which can cause fire and/or explosion.
  - In case of leaking fluid or a smell of burning, keep the battery away from sources of heat. Leaked fluid can catch fire.
  - A safety valve in the battery guarantees that any excess pressure caused by improper handling is discharged safely.
  - Batteries have only a limited service life. We recommend replacing them after around four years.
  - Take damaged batteries to a collection point to ensure correct recycling.
  - The batteries must not be exposed to heat, sunlight, humidity or moisture for long periods. Likewise, the batteries may not be placed in a microwave oven or a high pressure container as this results in a risk of fire or explosion.

**FOR THE CHARGER**

- The battery charger may only be used indoors.
- If the charger is used in the vicinity of radio receivers, it can interfere with the reception; make sure there is a distance of at least 1 m /3ft between the devices.
- When the charger is in use, it can make a noise (buzzing) – this is quite normal and is not a malfunction.
- When it is not in use, disconnect the charger from the mains as otherwise it uses a certain (very small) amount of power even when no battery is inserted in it.
- Always keep the charger contacts clean, and never short circuit them.
- The car charging cable supplied
  - may only be operated with 12V electrical systems,
  - may never be connected while the charger is connected to the mains.

**FOR MEMORY CARDS**

- While a picture is being stored or the memory card is being read, it may not be removed, nor may the camera be turned off or exposed to vibrations.
- For safety, memory cards should only ever be stored in the anti-static cover supplied.
- Do not store memory cards where they will be exposed to high temperatures, direct sunlight, magnetic fields or static discharge.
- Do not drop or bend a memory card as this can damage it and result in loss of the stored data.
- Always remove the memory card if you will not be using the camera for a long period of time,
- Do not touch the contacts on the rear of the memory card and keep them free of dirt, dust and moisture.
- It is recommended that the memory card be reformatted from time to time, as fragmentation occurs when deleting, which can block some of the memory capacity.

**Notes:**

- Simple formatting does not cause the data on the card to be irretrievably lost. Only the directory is deleted, which means that the existing files are no longer directly accessible. The data can be accessed again using appropriate software. Only the data that is then overwritten by saving new data is actually permanently deleted. You should nevertheless make a habit of transferring all your pictures onto a secure bulk storage medium, e.g. the hard drive on your computer, as soon as possible. This is particularly important if the camera is being sent for servicing along with the memory card.
- Depending on the memory card used, formatting can take up to 3 minutes.

## CLEANING THE SENSOR / DUST DETECTION

If any dust or dirt particles should adhere to the sensor cover glass, depending on the size of the particles this can be identified by dark spots or marks on the pictures.

You can use the **Dust detection** function to check whether or how many particles are on the sensor.. This is much more accurate than a visual inspection and is therefore a reliable method of assessing whether cleaning is required.

The camera can be returned to Leica Camera AG Customer Care department (address: see p. 248) for chargeable cleaning of the sensor; this cleaning is not covered by warranty.

You can also carry out cleaning yourself, using the **Sensor cleaning** function in the menu. This allows access to the sensor by keeping the shutter open.

### DUST DETECTION

1. In the main camera menu, (see p. 150/240) select **Sensor cleaning** (page 4/section **SETUP**).
  - The relevant sub-menu appears.
2. Select **Dust detection**.
  - The following message appears: **Attention Please close the aperture to the largest value [16 or 22], and take a picture of a homogeneous surface [defocussed].**
3. Press the shutter release button.
  - After a short time, a "picture" appears in the monitor, in which black pixels represent grains of dust.

### Note:

If dust detection is not possible, a corresponding message appears instead. After a few seconds, the display reverts to that described under 2. The picture can then be taken again.

### CLEANING

1. In the main camera menu (see p. 150/240) select **Sensor cleaning** (page 4/section **SETUP**).
  - The relevant sub-menu appears.
2. Select **Open shutter**.
3. Select **Yes**. If there is sufficient battery capacity, i.e. at least 60%, the shutter then opens.
  - The message **Please switch off camera after cleaning** appears.

### Note:

If the battery capacity is lower, the warning message **Attention Battery capacity too low for sensor cleaning** appears instead to indicate that the function is not available, i.e. **Yes** cannot be selected

4. Perform the cleaning. Make sure you follow the instructions below.
5. When cleaning is complete, turn off the camera. As a precaution, the shutter is only closed 10s later.
  - The message **Attention Please stop sensor cleaning immediately** appears.



**Notes:**

- Generally: To protect the camera against ingress of dust etc. into the interior of the camera, it is important always to have a lens or a cap on to the camera body.
- For the same reason, when changing lenses work quickly and in an environment that is as dust-free as possible.
- As plastic parts can easily pick up a static charge and then attract more dust, the lens caps and covers should only be stored for short periods in pockets in clothing.
- As far as possible, both inspection and cleaning of the sensor should be performed in a dust-free environment to prevent further soiling.
- Lightly adhering dust can be blown off the sensor cover glass using clean and, if necessary ionized gases such as air or nitrogen. It makes sense to use a (rubber) bellows with no brush for this purpose. Special, low pressure cleaning sprays such as "Tetenal Antidust Professional" can also be used in line with their specified usage.
- If the particles cannot be removed from the sensor in this way, please refer the matter to your Leica Information Service.
- If the battery capacity falls to lower than 40% while the shutter is open, the warning message **Attention Please stop sensor cleaning immediately** appears in the monitor. At the same time a beep tone will sound, which continues until the camera is turned off. Turning the camera off will cause the shutter to be closed again.
- Be absolutely sure in this case that the shutter window is clear, i.e. that no object can obstruct the closing movement of the shutter, otherwise damage may occur.

**Important:**

- Leica Camera AG accepts no liability for damage caused by the user when cleaning the sensor.
- Do not attempt to blow dust particles off the sensor cover glass using your mouth; even tiny droplets of saliva can cause marks that are difficult to remove.
- Compressed air cleaners with high gas pressure may not be used as they can also cause damage.
- Take care to avoid touching the sensor surface with any hard objects during inspection and cleaning.

## STORAGE

- If you are not using the camera for a longer period of time, we recommend that you:
  - a. remove the memory card (see p. 142), and
  - b. remove the battery (see p. 140), (after 2 months at the latest the date and time that were entered will be lost).
- A lens works like a magnifying glass if bright sunlight shines on the front of the camera. The camera must always be protected from strong sunlight. Use the lens cap and keep the camera in the shade (or immediately put it away in the case) help to prevent damage to the interior of the camera.
- You should preferably store the camera in a closed and padded container so that nothing can damage it and it is protected from dust.
- Store the camera in a dry, adequately ventilated place, where neither high temperatures nor high humidity will occur. When used in humid conditions, the camera should be completely free of all moisture before being stored away.
- Photo cases that became wet during use should be emptied to prevent damage to your equipment caused by moisture and any leather-tanning residue released.
- To prevent fungal growth during use in hot, humid tropical climates, the camera equipment should be exposed to the sun and air as much as possible. Storage in airtight containers or cases is recommended only if a desiccant such as silica gel is placed in the container.
- To prevent the formation of fungus, do not store the camera in a leather case for long periods of time.
- Note the serial numbers of your camera (engraved on the accessory shoe) and lenses, as these are extremely important in case of loss.

## TROUBLESHOOTING

### THE CAMERA DOES NOT RESPOND WHEN I TURN IT ON.

- Has the battery been correctly inserted?
- Does the battery have sufficient charge?  
*Use a charged battery.*
- Has the bottom cover been correctly attached?

### THE CAMERA TURNS ITSELF OFF AGAIN AS SOON AS I TURN IT ON.

- Does the battery have sufficient charge to operate the camera?  
*Charge the battery or insert a charged battery.*
- Is there any condensation?  
*This occurs if the camera is moved from a cold place to a hot place. In this case, wait until the condensation has evaporated.*

**THE CAMERA SHUTTER REFUSES TO TRIP.**

- Picture data is currently being transferred to the memory card and the back-up memory is full.
- The capacity of the memory card is exhausted and the back-up memory is full.

Delete pictures you no longer require before taking new ones.

- No memory card has been inserted and the back-up memory is full.

**I CANNOT SAVE THE PICTURE.**

- Is a memory card inserted?
- The capacity of the memory card is full.

Delete pictures you no longer require before taking new ones.

**THE MONITOR IS TOO DARK OR TOO BRIGHT.**

- When viewing the monitor image from wide angles it is always more difficult to see.

If it is too light or too dark although you are looking at the monitor full on: Set a different brightness, or use the EVF2 external electronic viewfinder available as an accessory (see p. 218).

**THE PICTURE I HAVE JUST TAKEN IS NOT SHOWN IN THE MONITOR**

- Is the **Auto Review** function turned on (when the camera is set to a picture mode)?

**I CANNOT DISPLAY THE PICTURE.**

- Is a memory card inserted?
- The memory card does not contain any data.

**DESPITE BEING CONNECTED TO A COMPUTER (USING THE CONNECTED MULTIFUNCTION HAND GRIP), I CANNOT TRANSFER ANY DATA.**

- Check whether the computer, multifunction M hand grip and camera are connected correctly.

**THE DATE AND TIME DISPLAYS SHOW INCORRECT VALUES OR ARE BLANK.**

- The camera has not been used for a long period, particularly if the battery has been removed.





Insert a fully charged battery.

Set the date and time.

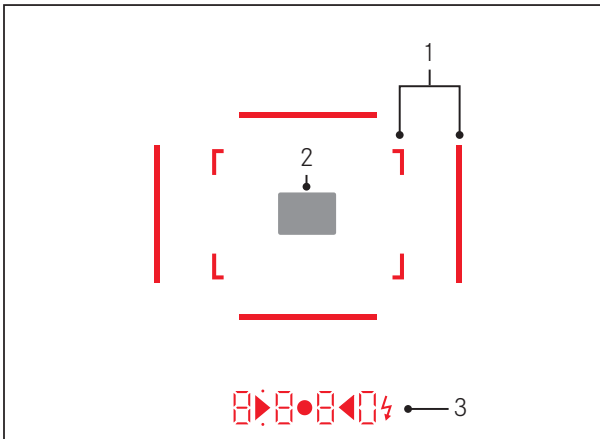
# APPENDIX

## VIEWFINDER DISPLAYS



1. Bright line frame for 50mm and 75mm<sup>1</sup> (example)
2. Metering field for distance setting
3. LEDs<sup>1</sup> (Light Emitting Diodes) for:
  - a. Four-digit digital display with dots above and below  
 Digital display:
    - Display of the automatically determined shutter speed for aperture priority A, or for counting down shutter speeds slower than 1s
    - Warning that the metering or setting ranges are overshot or undershot using aperture priority A
    - Displays the exposure compensation value (briefly during adjustment, or for about 0.5s when exposure metering is activated by tapping the shutter release)
    - Indicates that the back-up memory is (temporarily) full
    - Indicates that no memory card is loaded (SD)
    - Indicates that the memory card is full (Full)
  - b.  Dot above:
    - Indication (when lit) that saved metering values are being used
  - c.  Dot below:
    - Indicates (flashing) that exposure compensation is being used
  - d.  Two triangular and one circular LED:
    - For manual exposure setting: Together as a light balance for exposure compensation. The triangular LEDs give the direction of rotation of the aperture setting ring and shutter speed dial to adjust the exposure.
    - Warning of values below the metering range
  - e.  Flash symbol:
    - Flash ready to use
    - Details of flash exposure before and after the picture

<sup>1</sup> With automatic brightness control adjusted to the ambient brightness. This automatic control is not available for Leica M lenses with viewfinder attachments, since they cover the brightness sensor 5 which supplies the information required for their operation. In such cases the frame and displays always maintain a constant brightness.

## MONITOR DISPLAYS

## WHEN TAKING A PICTURE

## In Live View mode



- 1** Exposure mode
- 2** Shutter speed
- 3** Exposure metering mode
- 4** ISO sensitivity
- 5** Exposure lock
- 6** Exposure compensation

*(additional for spot metering)*

- 7** Metering field

*(in addition to 1-7, for video recordings)*

- 8** Elapsed recording time
- 9** Recording in progress indicator (flashing)

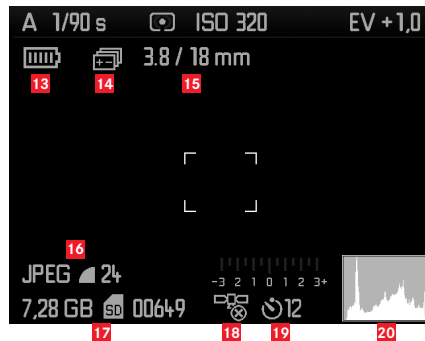
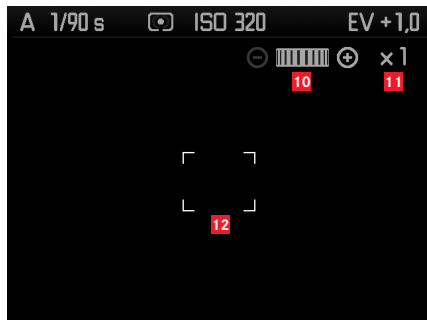

*(in addition to 1-9, by focusing the lens or pressing the focus button; alternative to 13-17; not for video recordings)*

- 10** Symbol for thumbwheel / available enlargement/reduction factors
- 11** Current zoom factor
- 12** Frame for trimming to be enlarged

*(in addition to 1-10, by pressing the INFO button; 13-15 alternatively to 10-12)*

- 13** Battery capacity
- 14** Exposure series
- 15** Lens speed / focal length or lens type
- 16** File format / compression / resolution or video format (depending on picture type)
- 17** Remaining memory capacity / number of pictures or time (depending on picture type)
- 18** GPS status (only with multifunction M hand grip attached)
- 19** Self-timer status / delay time
- 20** Picture histogram (not for video recordings)

In viewfinder mode, by pressing the INFO button

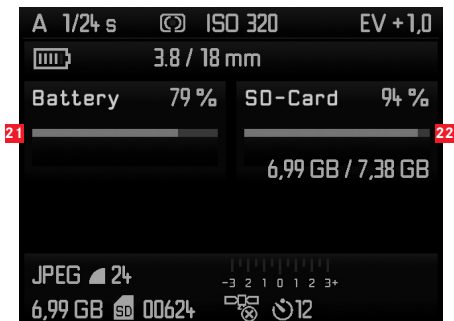



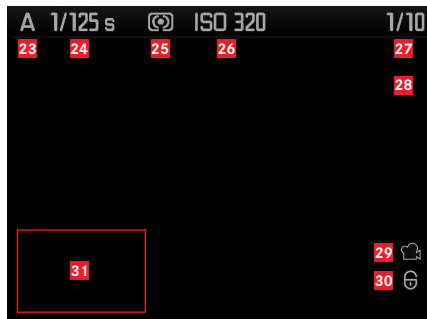

*(in addition to 1-7/13-21)*

- 21** Battery capacity
- 22** Memory card capacity





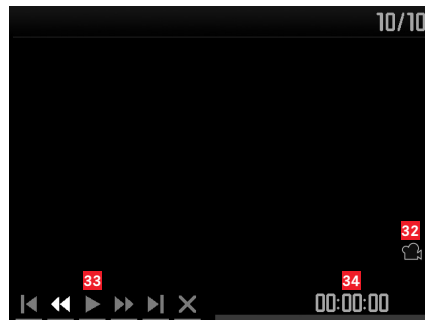

- 23** Exposure mode
- 24** Shutter speed
- 25** Exposure metering mode
- 26** ISO sensitivity
- 27** Number of picture displayed / total number of pictures on memory card
- 28**  Symbol for enlargement function / display of the detail size and position (only with details, other displays go out)
- 29**  Symbol for video recording
- 30**  Symbol for delete protected pictures
- 31**  Selected picture  
(example, reduced viewing of 4/9/36 pictures only)



*(in addition to 24-33, by pressing the INFO button during a video recording)*

- 32**  Symbol for video playback
- 33**  Video control symbols
- 34**  Elapsed playback time / progress bar

## With histogram

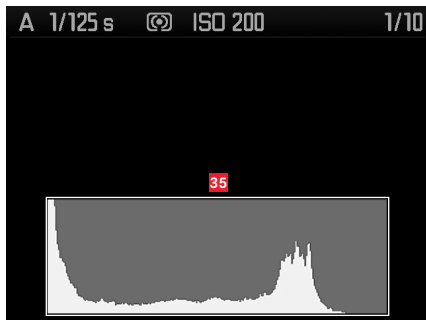

*(as for 24-36, additional)*

**35** Histogram

## With clipping displays



*(as for 24-36, picture areas without marking flash red/blue, additional)*

**36** Clipping symbol

## With additional information

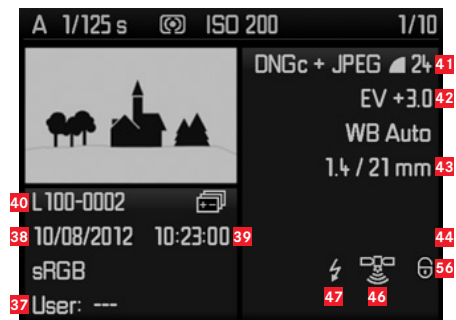

(in addition to 28-37, by pressing the **INFO** button, reduced picture)

- 37** User profile number/name
- 38** Date
- 39** Time
- 40** Folder number / file name
- 41** File format / compression / resolution or video format (depending on picture type)
- 42** Exposure compensation
- 43** Lens speed / focal length
- 44** Symbol for video recording
- 45** Symbol for delete protected pictures (only appears if pictures are selected)
- 46** GPS status (appears only with multifunction M hand grip attached)
- 47** Symbol for flash picture (not for video recordings)

## For menu control

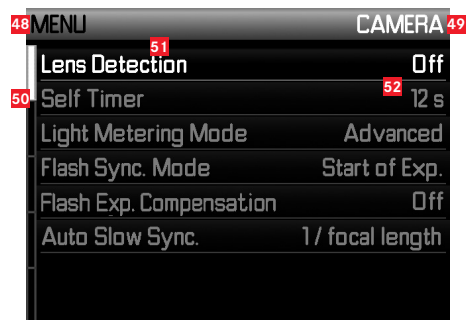

- 48** Specification of menu, **MENU** = main menu / **SET** = picture parameters menu
- 49** Specification of menu section (main menu only)
- 50** Scroll bar with page indication (main menu only)
- 51** Menu option
- 52** Menu option setting

## MENU OPTIONS

### MAIN MENU (MENU button)

#### CAMERA (page 1)

Lens Detection	see p. 158
Self Timer	see p. 192
Light Metering Mode	see p. 175
Flash Sync. Mode	see p. 188
Flash Exp. Compensation	see p. 187
Auto Slow Sync.	see p. 182

#### IMAGE (page 2)

Sharpness	see p. 163
Contrast	see p. 163
Toning	see p. 163
Shading Correction	see p. 159
DNG compression	see p. 160

#### SETUP (page 3)

Monitor Brightness	see p. 168
EVF Brightness	see p. 168
Frameline color	see p. 164
Focus Peaking	see p. 173
Focus Aid	see p. 172
Clipping Definition	see p. 203
Auto Review	see p. 199

#### SETUP (page 4)

Copyright Information	see p. 193
Image Numbering	see p. 211
Horizon	see p. 169
Sensor Cleaning	see p. 228
GPS	see p. 193
Audio	see p. 191
Exposure Simulation	see p. 169

**SETUP** (page 5)

Auto Power Off	see p. 156
Date / Time	see p. 154
Acoustic Signal	see p. 157
Language	see p. 154
USB Mode	see p. 213
Reset	see p. 197
Format SD card	see p. 212
Firmware	see p. 217

**PICTURE PARAMETERS MENU** (SET button)

ISO	see p. 161
File Format	see p. 159
JPEG Resolution	see p. 160
Video recording	see p. 160
Exposure bracketing	see p. 190
Exposure compensation	see p. 178
Exposure metering	see p. 174
User profile	see p. 195

## INDEX

Aperture priority .....	176
Aperture setting ring .....	132
Battery, inserting and removing .....	140
Bright-line frames.....	164
Bright-line view and range finder.....	164
Care instructions .....	222
Carrying strap .....	136
Cases .....	218
Cautions .....	222
Contrast, see image properties	
Copyright.....	193
Corrective lenses .....	218
Date/Time.....	154
Deleting pictures.....	206
Depth of field scale .....	132
Designation of parts.....	132
Detail, selection of the, see Review mode	
Displays	
in the monitor.....	234
in the viewfinder .....	232
Distance setting.....	173
Focusing aids .....	173
Metering field.....	164/232
On the monitor .....	172
Range finder.....	169
Setting ring .....	132
Split image method .....	171
Superimposed image method .....	171
DNG .....	159/244
Electronic viewfinder .....	218
Enlarging pictures .....	205
Exposure / exposure control / exposure meter	
Aperture priority .....	176
Automatic bracketing .....	179
Exposure compensation .....	178
Manual setting.....	182
Metering memory lock.....	177
Metering methods .....	174
Metering range .....	183
Switching OFF .....	174
Switching ON .....	174
Values above and below the metering range .....	183
File format .....	159
Filters .....	222
Firmware downloads .....	217
Flash mode .....	184
Flash exposure compensation.....	187
Flash units.....	184/218
HSS flash .....	188
Synchronization.....	188
Formatting the memory card .....	212
Frame rate .....	148
Frame selector .....	166
GPS .....	193
Hand grip M.....	218
Histogram.....	202/238
Horizon .....	169
Image properties (contrast, sharpness) .....	163
Interchangeable lenses .....	143/218
ISO sensitivity .....	161
Leica Customer Care.....	248
Leica Product Support .....	248

Lenses, Leica M .....	143	Sounds (key acknowledgment (response) tones) .....	157
Design .....	132	Volume control .....	157
Mounting and removing .....	145	Spare parts .....	221
Use of older lenses .....	143	Storage .....	230
Linear flash (HSS) .....	188	Technical data .....	244
Live View .....	168/172	Time and date .....	154
Main switch .....	146	Toning .....	163
Malfunctions and their resolution .....	230	Transferring data to a computer .....	213
Memory card, inserting and removing .....	142	Turning on / off .....	146
Menu control .....	150	Video recordings .....	190
Menu language .....	154	Viewfinder .....	164
Menu options .....	240	Bright-line frames .....	164/232
Microphone adapter M .....	218	Displays .....	232
Monitor .....	168	External viewfinders .....	218
Multifunction M hand grip .....	218	Vignetting correction .....	159
Package contents .....	247	Warning messages .....	130
Picture series .....	148	Viewing pictures	
Power off, automatic .....	156	with the Auto Review function .....	199
Protecting pictures / clearing delete protection .....	208	with the <b>PLAY</b> function .....	198
R adapter M .....	218		
Raw data (DNG) .....	160/216		
Repairs / Leica Customer Care .....	248		
Resetting all custom settings .....	197		
Resolution .....	160		
Review mode .....	198		
SCA adapter set .....	218		
Self-timer .....	192		
Shading correction .....	159		
Sharpness, see image properties			
Shutter release, see also shutter and Technical Data .....	147/244		
Shutter speed dial .....	149		
Shutter speed/aperture combination, see Exposure setting			
Sound recording .....	191		

## TECHNICAL DATA

### Camera type

Leica M Monochrom (Typ 246), compact digital view and range finder system camera with black-and-white sensor

### Lens mount

Leica M bayonet with additional sensor for 6-bit coding

### Lens system

Leica M lenses from 16 – 135mm

### Picture format / image sensor

B/W CMOS chip, active area approx. 23.9 x 35.8mm (corresponds to usable format of analog Leica M models) without color and low-pass filter

### Resolution

DNG™: 5976 x 3992 pixels (24MP),  
 JPEG: 5952 x 3968 pixels (24MP), 4256 x 2832 pixels (12MP),  
 2976 x 1984 pixels (6MP), 1600 x 1072 pixels (1.7MP);  
 For video recordings: 720P, 1080P

### Data formats

DNG™ (raw data), either uncompressed or compressed (lossless),  
 JPEG

### File size

DNG™: Compressed 20-30MB, uncompressed 34.5MB,  
 JPEG: Depending on resolution and picture content

### Video recording format

Motion JPG/Quicktime

### Video frame rates

24fps, 25fps

### Buffer memory

2GB / 30 pictures in series

### Sound recording

Mono, stereo using microphone adapter (see p. 221), choice of automatic or manual modulation during recording or fixed "Concert" setting

### Storage medium

SD cards up to 2GB / SDHC cards up to 32GB / SDXC cards

### Menu languages

German, English, French, Spanish, Italian, Japanese, Traditional Chinese, Simplified Chinese, Russian, Korean

### Compatibility

Windows® Vista® SP2/ 7® / 8®; Mac® OS X (10.5 or higher)

### Exposure metering

Through the Lens (TTL) metering, with variable aperture, center-weighted TTL metering for flash exposure with system-compliant SCA-3000/2 standard flash units

### Metering principle / method

By metering the light reflected by light blades of the 1st shutter curtain onto a measuring cell: Strong center-weighted; for metering on the sensor: Spot, center-weighted, multi-field metering

### Metering range

(to ISO320, room temperature and normal relative humidity:) EVO (with aperture 1.0) to EV20 (with aperture 32) Flashing of the left-hand triangular LED in the viewfinder signals that the exposure meter reading is below the working range



**Sensitivity range**

ISO 320 to ISO 12500, adjustable in  $1/3$  ISO increments, choice of automatic control or manual setting

**Exposure mode**

Choice of automatic shutter speed control with manual aperture preselection - aperture priority **A**, or manual shutter speed and aperture setting

**Flash exposure control****Flash unit attachment**

Using accessory shoe with center and control contacts or using SCA adapter set (see p. 220)

**Synchronization**

Optionally triggered at the 1st or 2nd shutter curtain

**Flash sync speed**

 =  $1/180$ s; slower shutter speeds can be used, if working below sync speed: Automatic changeover to TTL linear flash mode with HSS-compatible Leica system flash units

**Flash exposure metering**

(with SCA-3502-M5 adapter or SCA-3000 standard flash unit, e.g. Leica SF 26) Control with center-weighted TTL pre-flash metering

**Flash measurement cell**

2 silicon photo diodes with collection lens on the camera base

**Flash exposure compensation**

$\pm 3 1/3$  EV, adjustable in  $1/3$  EV steps via the menu, and when using correspondingly equipped Leica system flash units

**Displays in flash mode** (in viewfinder only)

Ready: Constant illumination of flash symbol LED in viewfinder

**Viewfinder****Viewfinder principle**

Large, bright-line frame viewfinder with automatic parallax compensation

**Eyepiece**

Calibrated to  $-0.5$  dpt.; corrective lenses from  $-3$  to  $+3$  diopter available

**Image field indication**

By activating two bright-line frames each: For 35 and 135mm, or for 28 and 90mm, or for 50 and 75mm; automatic switching when lens is attached; frame color (red/white) selectable in menu

**Parallax compensation**

The horizontal and vertical difference between the viewfinder and the lens is automatically compensated according to the relevant distance setting, i.e. the viewfinder bright-line frame automatically aligns with the subject detail recorded by the lens

**Matching viewfinder and actual image**

At a range setting of 2m, the bright-line frame size corresponds exactly to the sensor size of approx. 23.9 x 35.8mm; at infinity setting, depending on the focal length, approx. 7.3% (28mm) to 18% (135mm) more is recorded by the sensor than indicated by the corresponding bright line frame and slightly less for shorter distance settings than 2m

**Magnification** (For all lenses)

0.68 x

**Large-base rangefinder**

Split or superimposed image range finder shown as a bright field in the center of the viewfinder image

**Effective metering basis**

47.1 mm (mechanical measurement basis 69.25mm x viewfinder magnification 0.68x)

**Displays****In the viewfinder**

Four-digit digital display with dots above and below, displays, see p. 232

**On back**

3" TFT LCD monitor with 16 million colors and 921,600 pixels, approx. 100% image field, max. 170° viewing angle, glass cover of extremely hard, scratch-resistant sapphire crystal for Live View and review mode, displays see p. 234

**Shutter and shutter release button****Shutter**

Metal blade focal plane shutter with vertical movement

**Shutter speeds**

For aperture priority: **(A)** continuous from 60s to  $1/4000$ s.,

For manual adjustment: 8s bis  $1/4000$ s in half steps,

**B:** For long exposures up to maximum 60s (in conjunction with self-timer T function, i.e. 1st release = shutter opens, 2nd release = shutter closes).

⚡ ( $1/180$ s): Fastest shutter speed for flash synchronization, HSS linear flash mode possible with all shutter speeds faster than  $1/180$ s with HSS-compatible Leica system flash units); for video recordings (aperture priority and manual mode):  $1/30$  to  $1/4000$ s, for manual mode possible override of specified shutter speed to ensure correct exposure

**Activation of shutter**

By integrated motor, low noise operation

**Picture series**

Approx. 3 pictures/s, ≤ 30 pictures in series

**Shutter release button**

For single pictures: Two-stage, 1. Activation of exposure metering and exposure lock (in aperture priority mode), 2. Shutter release; standard thread for cable release integrated.

**Self-timer**

Delay optionally 2s (aperture priority and manual exposure setting) or 12s, set in menu, indicated by flashing LED on front of camera and corresponding display in monitor.

**Turning the camera on/off**

Using main switch on top of camera; optional automatic shutdown of camera electronics after approx. 2/5/10 minutes; reactivated by tapping the shutter release

**Power supply**

1 lithium ion battery, rated voltage 7.4V, capacity 1800mAh, capacity indicated in top panel display, when shutter held open (for sensor cleaning) additional acoustic warning of low capacity, maximum charging current/voltage: DC, 1100mA/ 8,25V. Model no.: BP-SCL2, Manufacturer: VARTA Microbattery, made in Indonesia

**Charger**

Inputs: 100-240V AC, 50/60Hz, automatic switching, or 12V DC, 1.3A; Output: DC, 7.4V, 1000mA. Model no.: BC-SCL2, Manufacturer: Guangdong PISEN Electronics Co., Ltd., made in China

**GPS**

Optional (only with multifunction hand grip attached; see p. 220), not available everywhere due to country-specific legislation, i.e. enforced automatic shutdown in those countries), data written to EXIF header in picture files.

**Level indication**

Measurement using 3-level acceleration sensor, measuring range: inclination (about transverse axis) and tilt (about longitudinal axis) each  $\pm 90^\circ$ , measuring accuracy / display sensitivity:  $\leq 1^\circ$  at 0-40°C / 32-104°F and horizontal alignment, display in monitor

**Camera body****Material**

All-metal die cast magnesium body, synthetic leather covering. Brass top panel and base, black chrome plated finish

**Frame selector**

Allows the bright-line frame pairs to be manually activated at any time (e.g. to compare detail)

**Tripod thread**

A  $\frac{1}{4}$  ( $\frac{1}{4}$ ") DIN stainless steel in bottom

**Operating conditions**

0-40°C / 32-104°F

**Interfaces**

ISO hot shoe, accessory socket, contact strip for Multifunction Hand Grip M

**Dimensions**

(Width x Depth x Height) Approx. 138.6 x 42 x 80mm /  $5\frac{15}{32} \times 1\frac{21}{32} \times \frac{35}{32}$ "

**Weight**

Approx. 680g / 24oz. (with battery)

**Scope of delivery**

Charger 100-240V with 2 mains cables (Euro, USA, varies in some export markets) and 1 car charging cable, lithium ion battery, carrying strap, body bayonet cover, cover for accessory shoe / accessory socket, Adobe® Photoshop® Lightroom® license

Subject to changes in design, production and availability.

## LEICA PRODUCT SUPPORT

The Product Support Department at Leica AG can provide you with an answer to any technical questions relating to Leica products, including software supplied, either in writing, on the telephone or by e-mail.

They are also the contact point for purchasing advice and to order instructions. Alternatively, you can send us your questions using the contact form on the Leica Camera AG homepage.

Leica Camera AG

Product Support / Software Support

Am Leitz-Park 5

D-35578 Wetzlar

Telephone: +49(0)6441-2080-111 /-108

Fax: +49(0)6441-2080-490

[info@leica-camera.com](mailto:info@leica-camera.com) / [software-support@leica-camera.com](mailto:software-support@leica-camera.com)

## LEICA CUSTOMER CARE

For servicing your Leica equipment or in the event of damage, the Leica Camera AG Customer Care department or the repair service provided by authorized Leica agents in your country are available (see the Warranty Card for a list of addresses).

Leica Camera AG

Customer Care

Am Leitz-Park 5

D-35578 Wetzlar

Telephone: +49(0)6441-2080-189

Fax: +49(0)6441-2080-339

[customer.care@leica-camera.com](mailto:customer.care@leica-camera.com)



my point of view

Leica Camera AG | Am Leitz-Park 5 | 35578 WETZLAR | DEUTSCHLAND  
Telefon +49 (0) 644 1-2080-0 | Telefax +49 (0) 644 1-2080-333 | [www.leica-camera.com](http://www.leica-camera.com)